

This document is best viewed at a screen resolution of 1024 X 768.

To set your screen resolution do the following:
RIGHT CLICK on the **DESKTOP**.
 Select **PROPERTIES**.
CLICK the **SETTINGS TAB**.
MOVE THE SLIDER under **SCREEN RESOLUTION** until it shows **1024 X 768**.
CLICK OK to apply the resolution.

The Bookmarks panel will allow you to quickly navigate to points of interest.

Open/Close Bookmark Panel

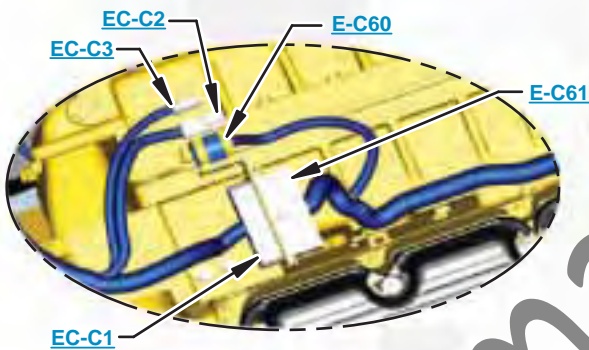

Click on any text that is BLUE and underlined. These are hyperlinks that can be used to navigate the schematic and machine views.

VIEW ALL CALLOUTS

When only one callout is showing on a machine view this button will make all of the callouts visible. This button is located in the top right corner of every machine view page.

HOTKEYS (Keyboard Shortcuts)		
	FUNCTION	KEYS
+	Zoom In	"CTRL" / "+"
-	Zoom Out	"CTRL" / "-"
□	Fit to Page	"CTRL" / "0" (zero)
☞	Hand Tool	"SPACEBAR" (hold down)
	Find	"CTRL" / "F"



Schematic

330D and 336D Excavator Hydraulic System - Attachment

330D:
GGE1-UP
THJ1-UP
PEL1-UP
LRM1-UP
ERN1-UP
RAS1-UP
T2Y1-UP

336D:
LMG1-UP
MYG1-UP
PPN1-UP
JWR1-UP

Fine Filtration

COMPONENT LOCATIONS



Description	Part Number	Machine Location	Schematic Location
FINE FILTRATION ATTACHMENT			
FILTER GP - OIL (HYDRAULIC)	250-0728	1	B-9
SCHEMATIC - HEAVY LIFT AND FINE SWING	259-7491		
MAIN SCHEMATIC - HEAVY LIFT AND FINE SWING			
ACCUMULATOR - HYDRAULIC (PILOT OIL)	NOTE B	A	B-7
CYLINDER GP - BOOM	NOTE A	3	F-3
CYLINDER GP - BUCKET	NOTE A	4	F-4
CYLINDER GP - STICK	NOTE A	5	F-9
FILTER GP - OIL (CASE DRAIN)	NOTE B	6	A-9
FILTER GP - OIL (HYDRAULIC RETURN)	NOTE B	7	A-9
FILTER GP - OIL (PILOT)	NOTE B	8	A-5
MANIFOLD GP - CONTROL (PILOT OIL)	NOTE B	9	B-8
MOTOR GP - PISTON	NOTE B	10	A-10
MOTOR GP - SWING	NOTE B	11	G-8
MOTOR GP - TRAVEL (LEFT)	NOTE B	12	G-7
(RIGHT)		13	G-5
PUMP GP - PISTON (HYDRAULIC FAN)	NOTE B	14	B-4
PUMP GP - PISTON (MAIN)	NOTE B	15	B-3
SWIVEL GP	NOTE B	16	E-6
VALVE GP - CHECK (OIL COOLER BYPASS)	NOTE B	17	B-10
VALVE GP - LOAD CONTROL (BOOM DRIFT RED, RELIEF LINE)	NOTE B	A	D-3
VALVE GP - LOAD CONTROL (STICK DRIFT RED, RELIEF LINE)	NOTE B	19	D-7
VALVE GP - MAIN CONTROL	NOTE B	20	D-2
VALVE GP - PILOT CONTROL (LEFT JOYSTICK)	NOTE B	21	D-10
VALVE GP - PILOT CONTROL (RIGHT JOYSTICK)	NOTE B	22	D-9
VALVE GP - PILOT (TRAVEL)	NOTE B	23	E-10
VALVE GP - PRESSURE REDUCING (BOOM, SWING PRIORITY)	NOTE B	A A	A-6 B-5
VALVE GP - PRESSURE REDUCING (STICK-IN PRIORITY)	NOTE B	A	B-6
VALVE GP - SHUTTLE	NOTE B	27 28	C-10 B-5
VALVE GP - SOLENOID (HEAVY LIFT)	NOTE B	A	B-5
VALVE GP - SWING CUSHION (FINE SWING)	NOTE B	30	F-8
VALVE GP - TRAVEL COUNTERBALANCE (LEFT)	NOTE B	31	F-7
(RIGHT)		32	F-5

Note A: Refer to parts manual for specific cylinder information.

Note B: Part numbers are located on the main Hydraulic System Schematic according to the effectivity of the machine.

Tap Locations Pressure, Sampling, and Sensor

Tap Number	Description	Schematic Location
<u>AA</u>	Pilot Filter Pressure Test Port	<u>A-5</u>
<u>BB</u>	Drive Pump Pressure Test Port	<u>B-2</u>
<u>CC</u>	Power Shift Pressure Test Port	<u>B-2</u>
<u>DD</u>	Idler Pump Pressure Test Port	<u>A-2</u>
EE	Fine Filtration Pressure Test Port	<u>B-9</u>
<u>SOS</u>	Hydraulic Oil Sampling Port	<u>A-5</u>

SchematicCat.com

FLUID POWER SYMBOLS



BASIC COMPONENT SYMBOLS

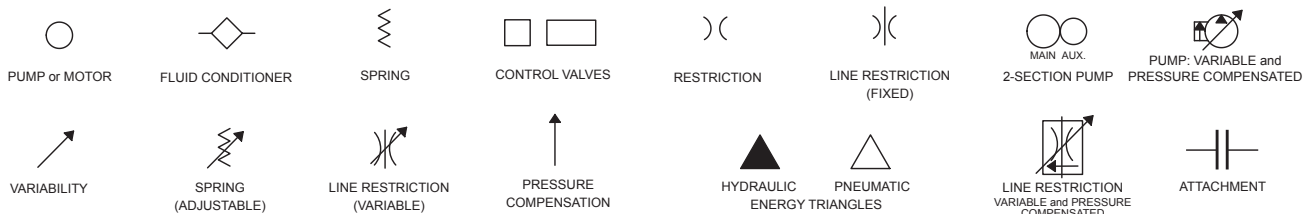

VALVE ENVELOPES

VALVES

VALVE PORTS

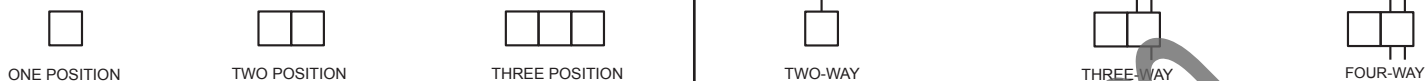

CONTROL VALVES

CHECK VALVES

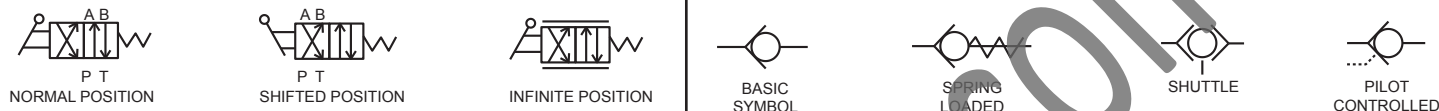

FLUID STORAGE RESERVOIRS



MEASUREMENT

ROTATING SHAFTS



COMBINATION CONTROLS



MANUAL CONTROL SYMBOLS



RELEASED PRESSURE

PILOT CONTROL SYMBOLS

REMOTE SUPPLY PRESSURE



ACCUMULATORS

CROSSING AND JOINING LINES

HYDRAULIC AND PNEUMATIC CYLINDERS



HYDRAULIC PUMPS

HYDRAULIC MOTORS

INTERNAL PASSAGEWAYS

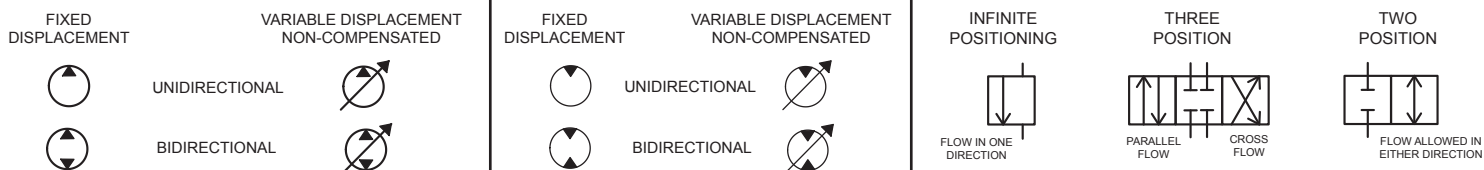

Hydraulic Symbols (Electrical)



Transducer
(Fluid)

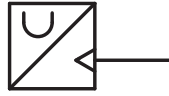

Transducer
(Gas / Air)



Generator



Electric Motor

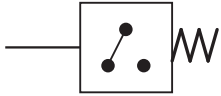

Pressure Switch

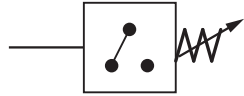

Pressure Switch
(Adjustable)

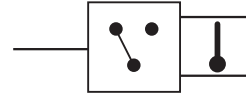

Temperature Switch



Electrical Wire

Electrical Symbols (Electrical)

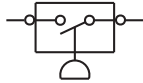

Pressure
Symbol

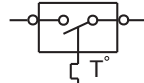

Temperature
Symbol



Level
Symbol

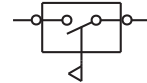

Flow
Symbol

Wire Number Identification Codes

Electrical Schematic Example

Current Standard

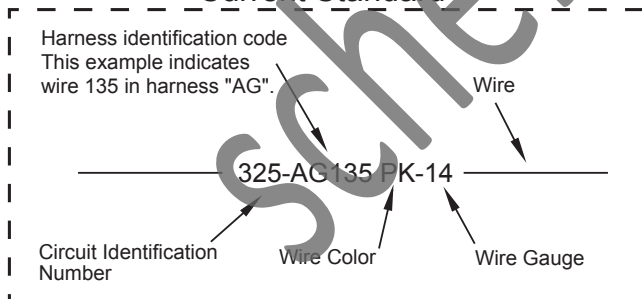

Previous Standard

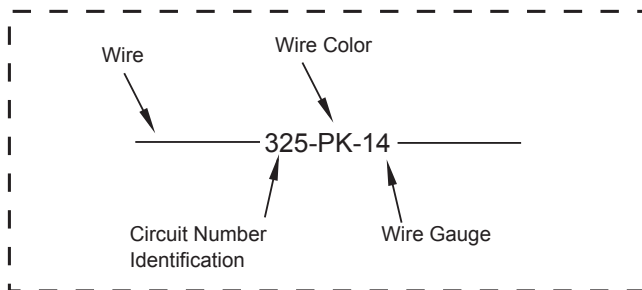

Hydraulic Schematic Example

Current Standard

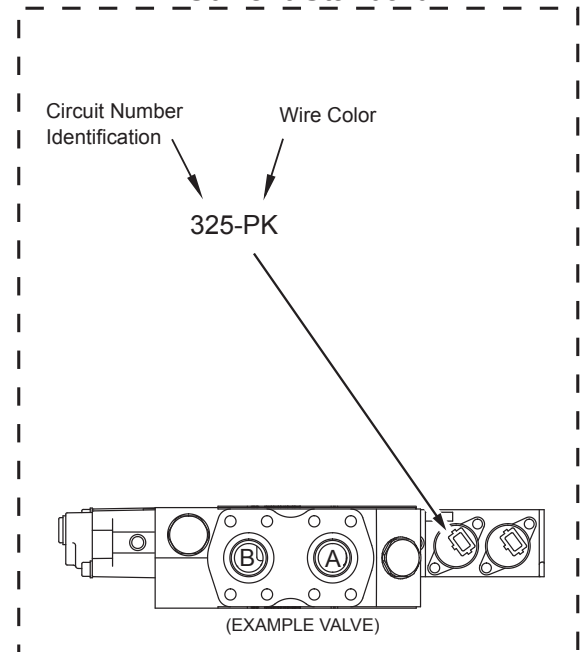

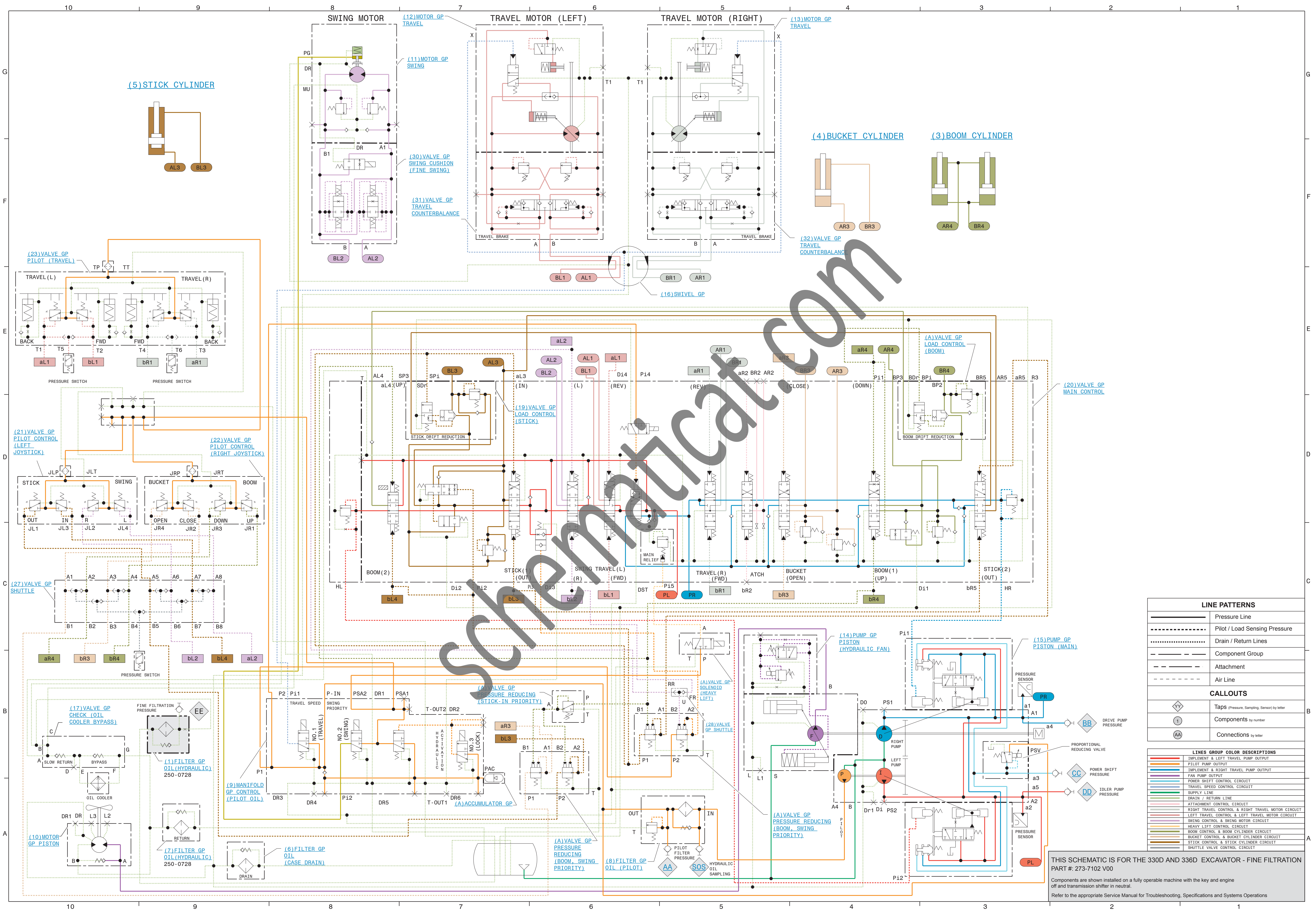

LINE PATTERNS	
	Pressure Line
	Pilot / Load Sensing Pressure
	Drain / Return Lines
	Component Group
	Attachment
	Air Line

CALLOUTS	
	Taps (Pressure, Sampling, Sensor) by letter
	Components by number
	Connections by letter

LINES GROUP COLOR DESCRIPTIONS	
	IMPLEMENT & LEFT TRAVEL PUMP OUTPUT
	PILOT PUMP OUTPUT
	IMPLEMENT & RIGHT TRAVEL PUMP OUTPUT
	FAN PUMP OUTPUT
	POWER SHIFT CONTROL CIRCUIT
	TRAVEL SPEED CONTROL CIRCUIT
	SUPPLY LINE
	DRAIN / RETURN LINE
	ATTACHMENT CONTROL CIRCUIT
	RIGHT TRAVEL CONTROL & RIGHT TRAVEL MOTOR CIRCUIT
	LEFT TRAVEL CONTROL & LEFT TRAVEL MOTOR CIRCUIT
	SWING CONTROL & SWING MOTOR CIRCUIT
	HEAVY LIFT CONTROL CIRCUIT
	BOOM CONTROL & BOOM CYLINDER CIRCUIT
	BUCKET CONTROL & BUCKET CYLINDER CIRCUIT
	STICK CONTROL & STICK CYLINDER CIRCUIT
	SHUTTLE VALVE CONTROL CIRCUIT

THIS SCHEMATIC IS FOR THE 330D AND 336D EXCAVATOR - FINE FILTRATION PART #: 273-7102 V00

Components are shown installed on a fully operable machine with the key and engine off and transmission shifter in neutral.

Refer to the appropriate Service Manual for Troubleshooting, Specifications and Systems Operations

MACHINE COMPONENT LOCATIONS

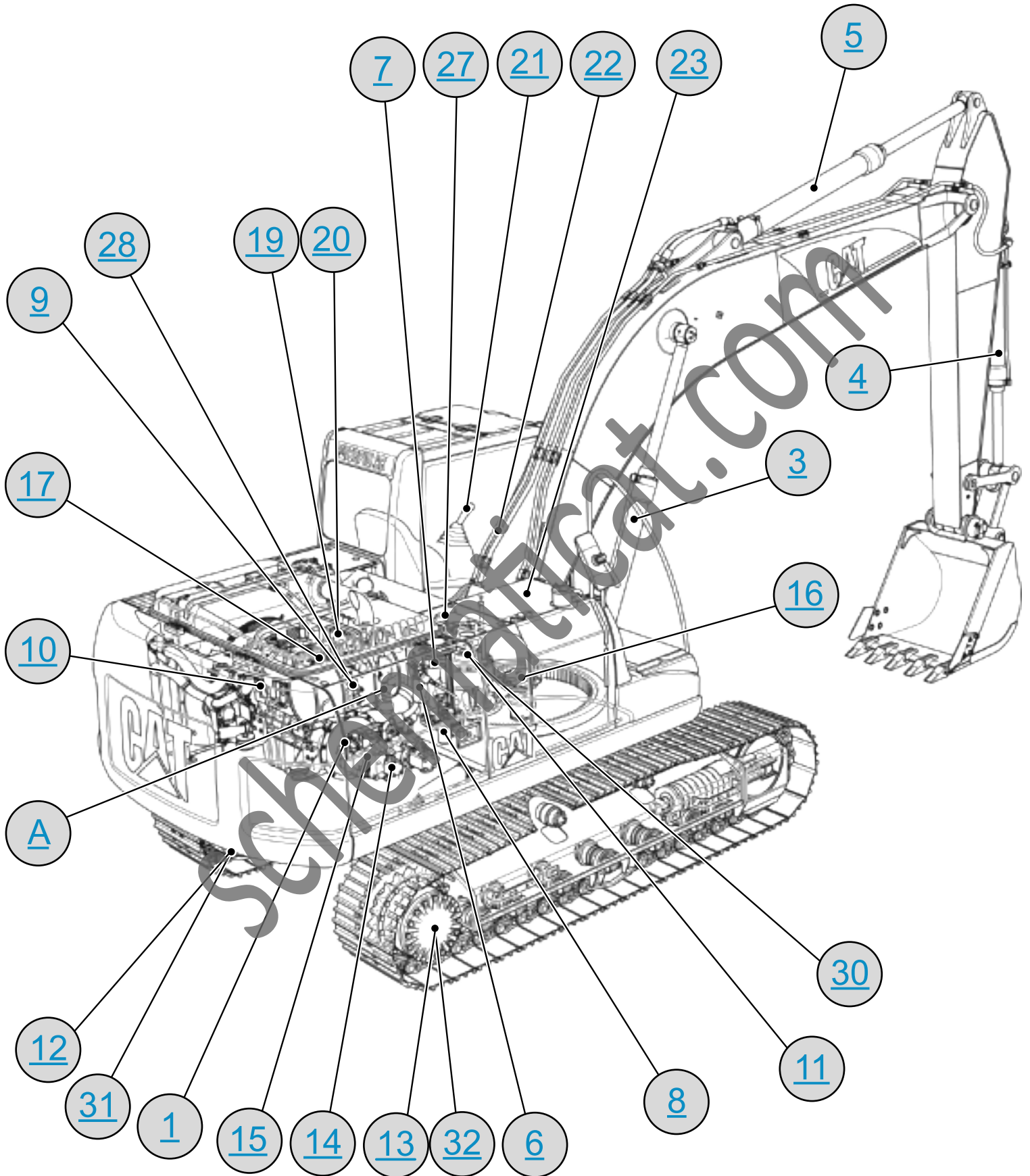

ACCUMULATOR

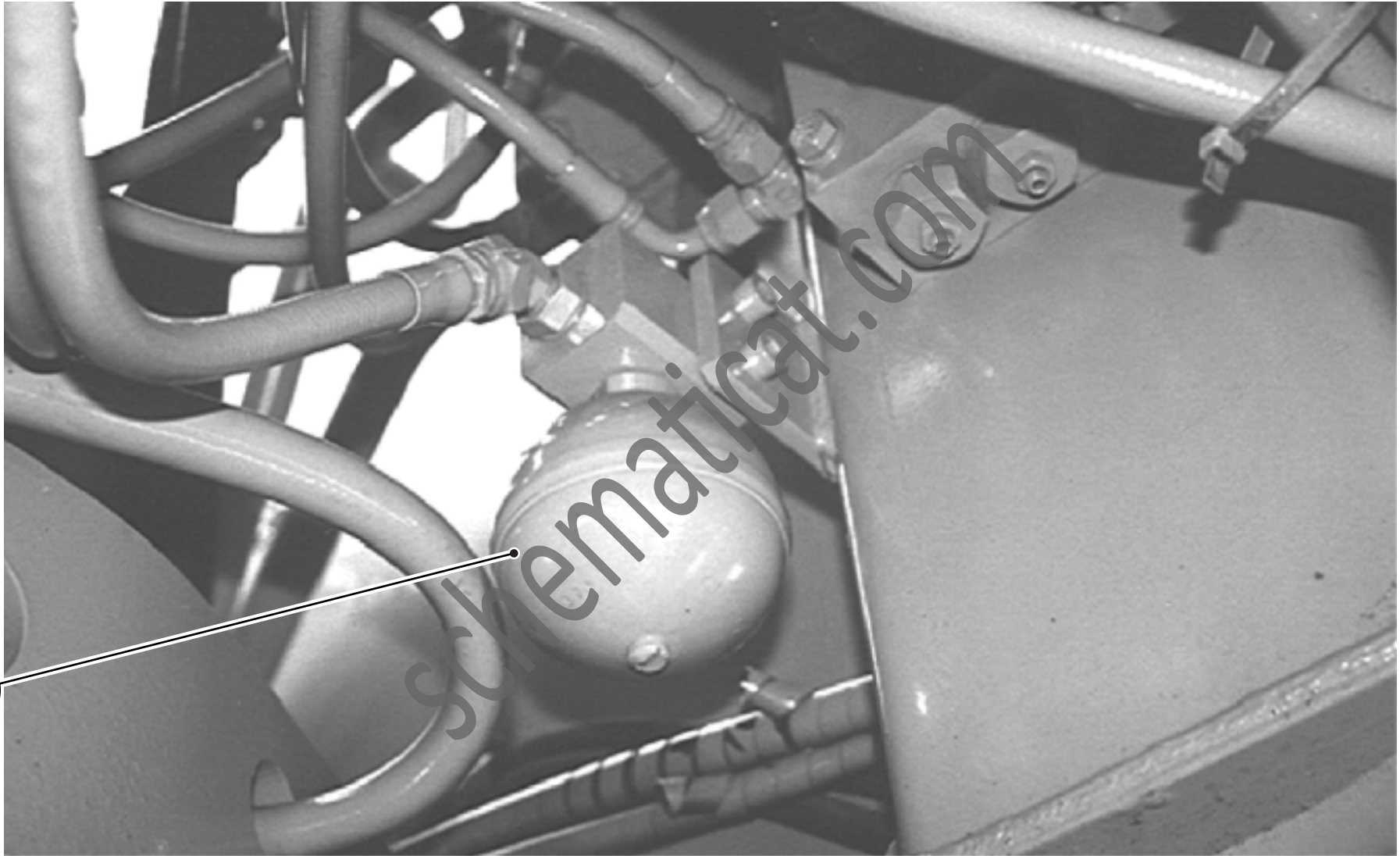

A

LINES GP - FILTER (FINE FILTRATION)

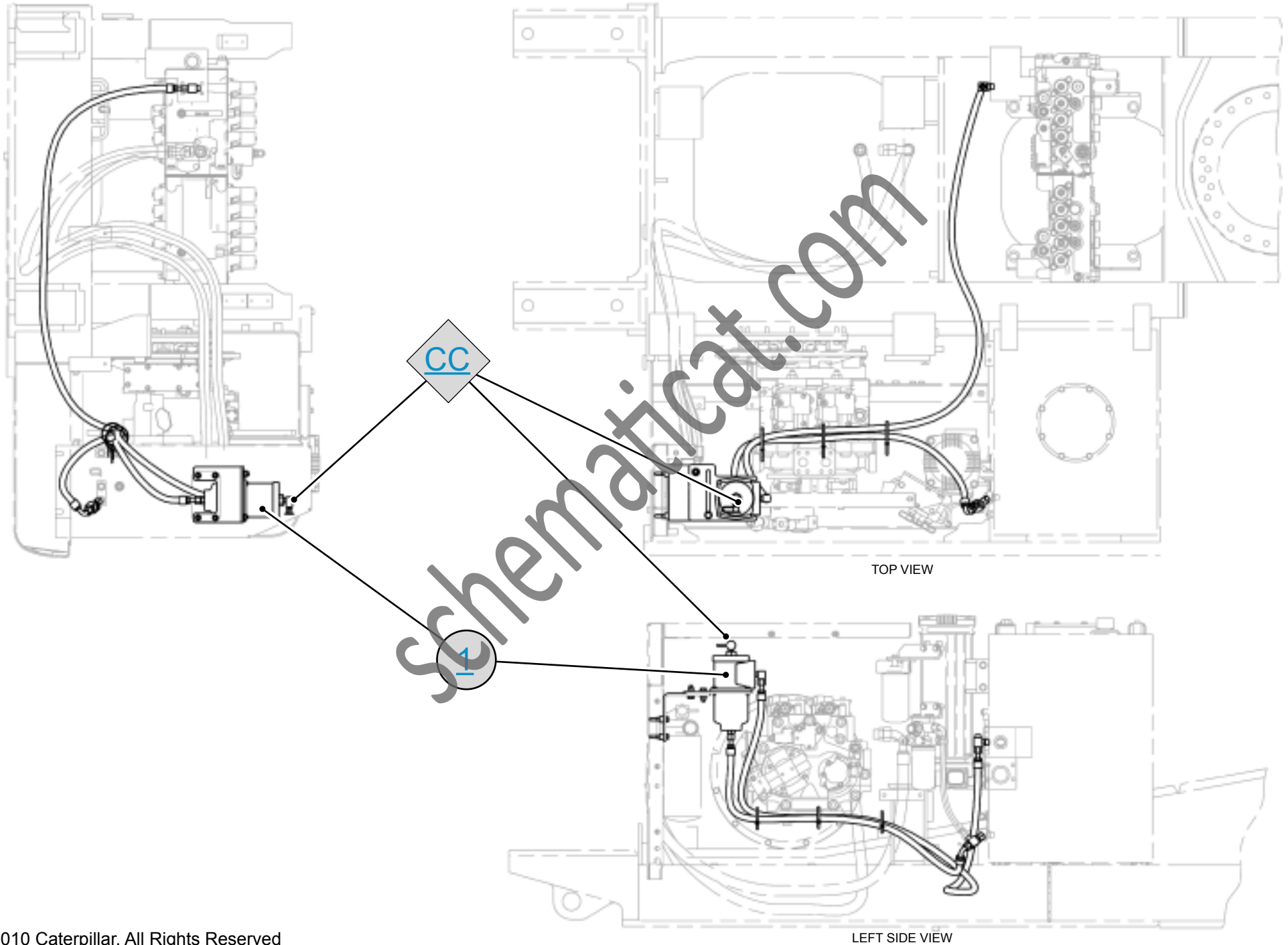

MOTOR GP - SWING SWIVEL

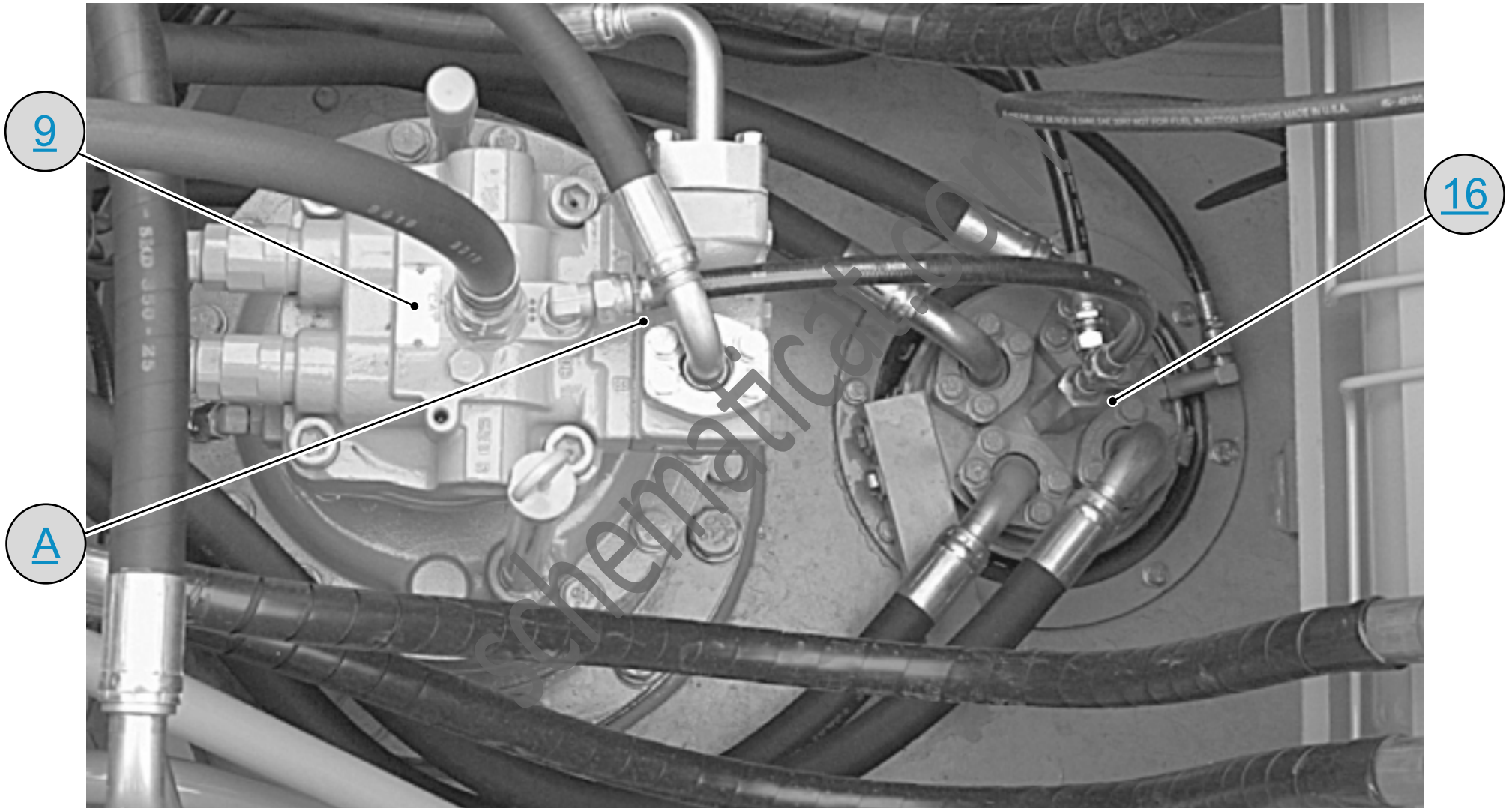

PUMP GP - PISTON (MAIN)

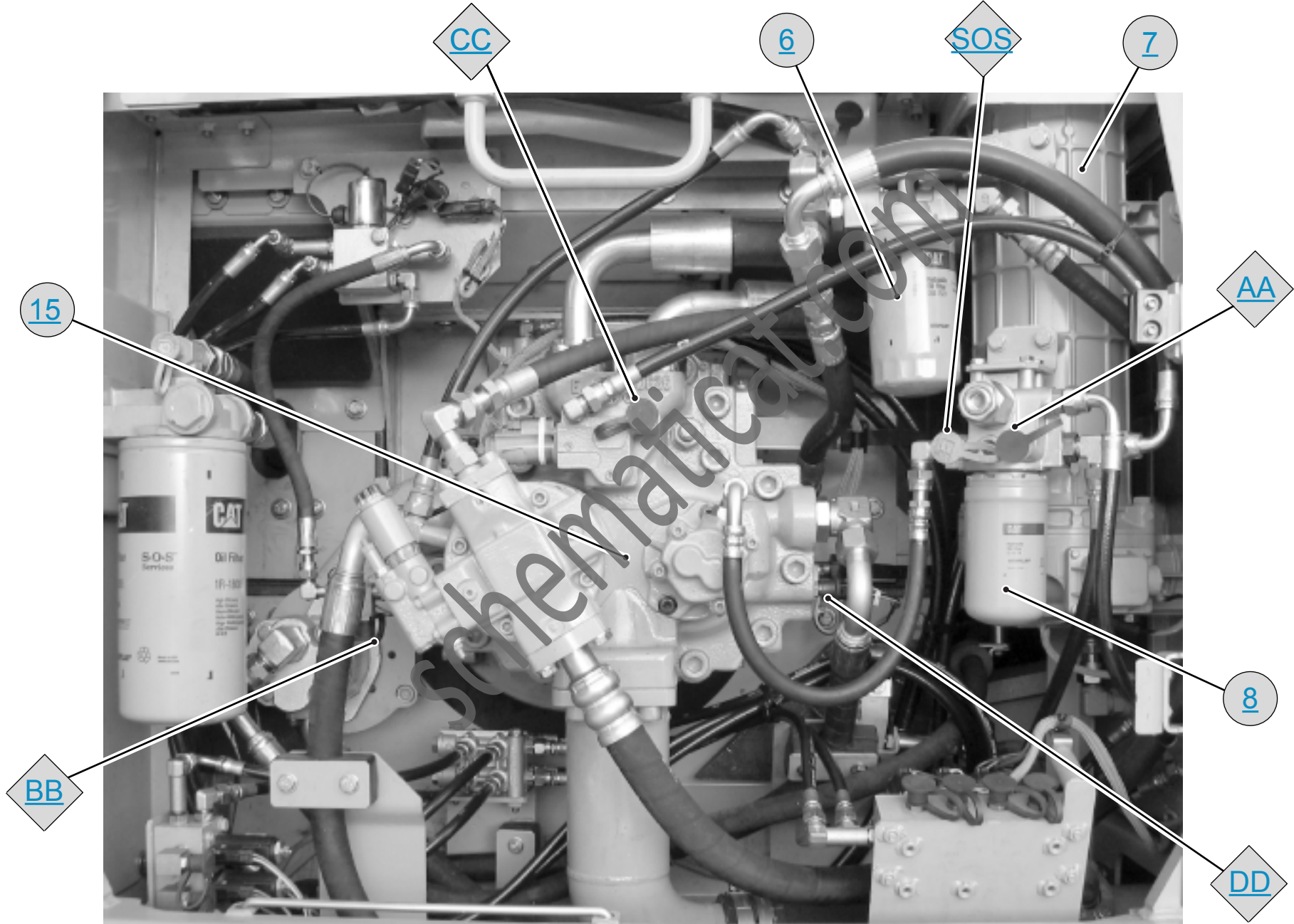

VALVE GP - MAIN CONTROL

