

Schematic

D10N Tractor Hydraulic System

2YD (Later)
3SK1-UP

SchematicCat.com



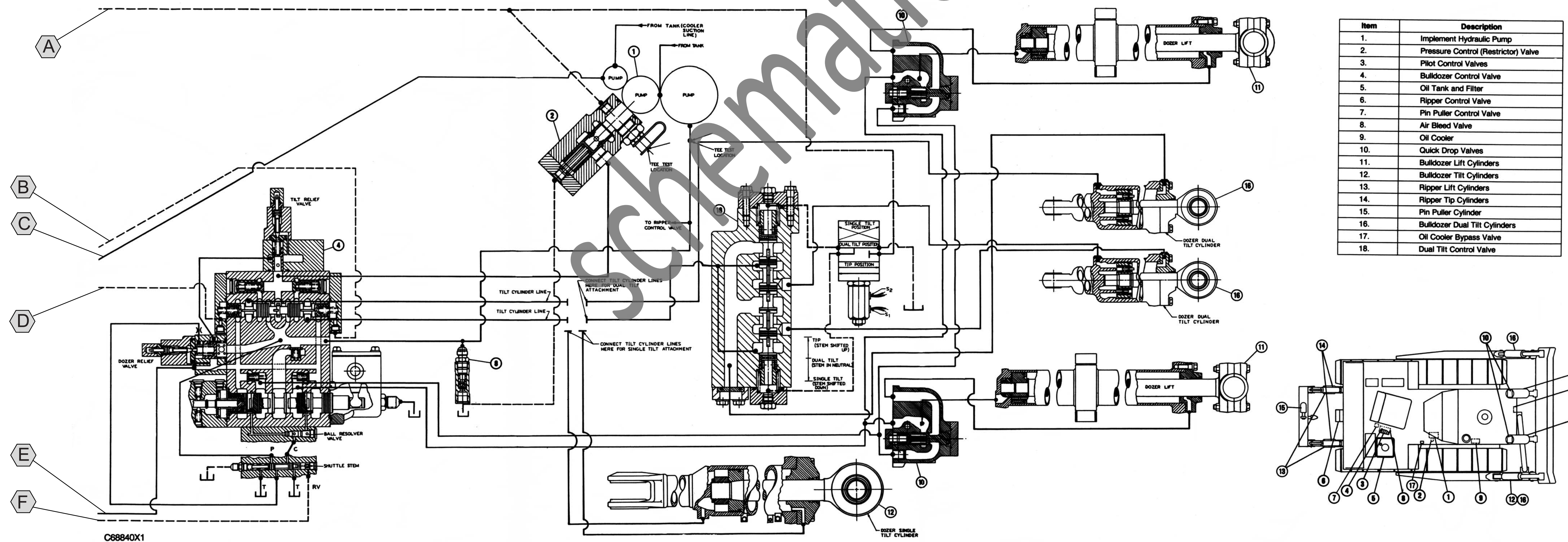
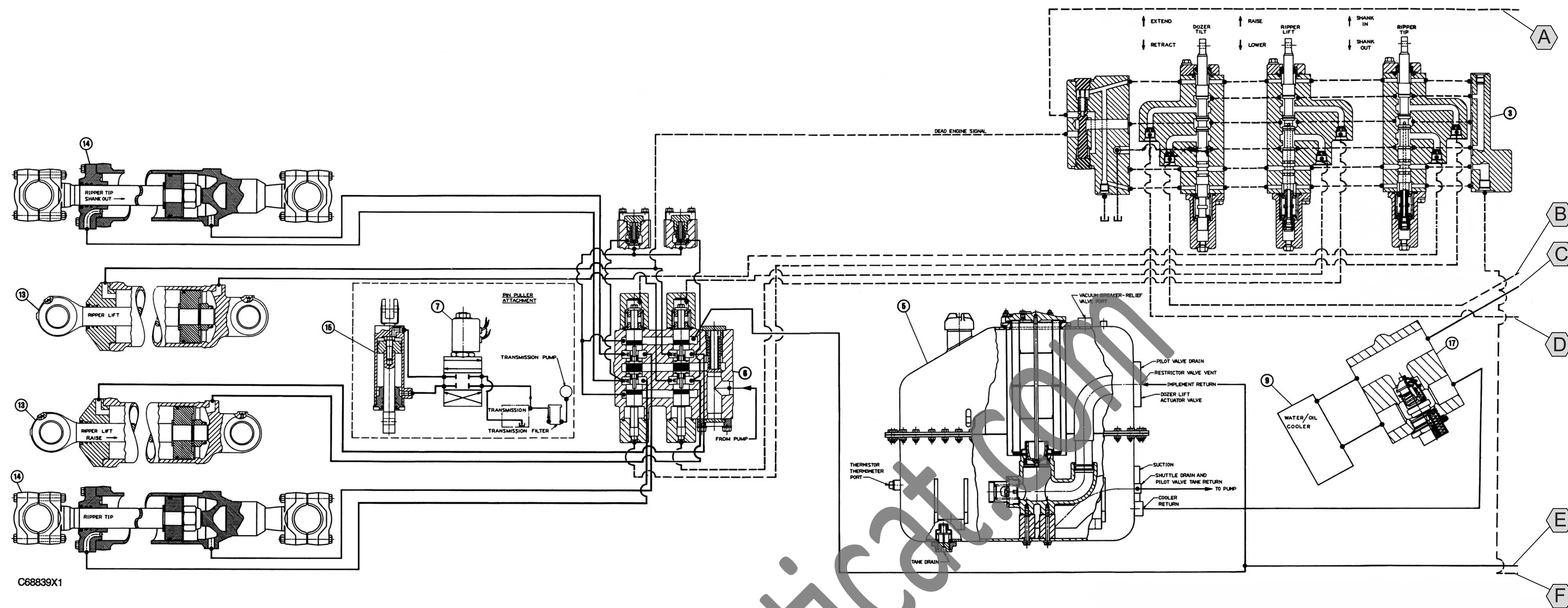

Item	Description
1.	Implement Hydraulic Pump
2.	Pressure Control (Restrictor) Valve
3.	Pilot Control Valves
4.	Bulldozer Control Valve
5.	Oil Tank and Filter
6.	Ripper Control Valve
7.	Pin Puller Control Valve
8.	Air Bleed Valve
9.	Oil Cooler
10.	Quick Drop Valves
11.	Bulldozer Lift Cylinders
12.	Bulldozer Tilt Cylinders
13.	Ripper Lift Cylinders
14.	Ripper Tip Cylinders
15.	Pin Puller Cylinder
16.	Bulldozer Dual Tilt Cylinders
17.	Oil Cooler Bypass Valve
18.	Dual Tilt Control Valve

