

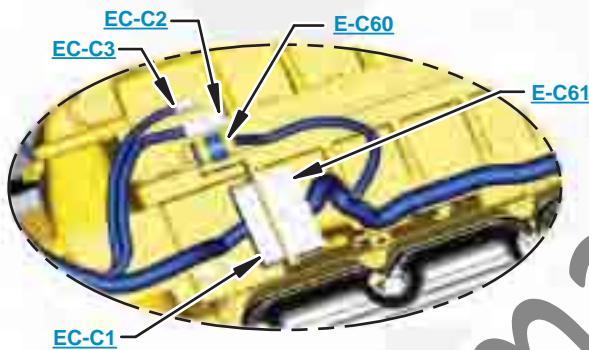

This document is best viewed at a screen resolution of 1024 X 768.

To set your screen resolution do the following:
RIGHT CLICK on the **DESKTOP**.
 Select **PROPERTIES**.
CLICK the **SETTINGS TAB**.
MOVE THE SLIDER under **SCREEN RESOLUTION** until it shows **1024 X 768**.
CLICK OK to apply the resolution.

The Bookmarks panel will allow you to quickly navigate to points of interest.



Click on any text that is BLUE and underlined. These are hyperlinks that can be used to navigate the schematic and machine views.

VIEW ALL CALLOUTS

When only one callout is showing on a machine view this button will make all of the callouts visible. This button is located in the top right corner of every machine view page.

HOTKEYS (Keyboard Shortcuts)		
	FUNCTION	KEYS
	Zoom In	"CTRL" / "+"
	Zoom Out	"CTRL" / "-"
	Fit to Page	"CTRL" / "0" (zero)
	Hand Tool	"SPACEBAR" (hold down)
	Find	"CTRL" / "F"



Schematic

D11R and D11R CD
Track-Type Tractor
Electrical System

D11R:
7PZ881-UP

D11R CD:
AAF228-UP

SchematicCat.com

COMPONENT LOCATION

Page 1 of 3



Component	Schematic Location	Machine Location	Component	Schematic Location	Machine Location
Alarm - Action	G-16	A	Sensor - Lift Cylinder Position Left ATCH ²	J-4	15
Alarm - Backup	J-14	1	Sensor - Lift Cylinder Position Right ²	C-4	16
Alarm - Ladder	E-2	69	Sensor - Makeup Oil Level ATCH	J-5	37
Alternator	H-4	2	Sensor - Pressure Atmospheric	E-3	38
Arc Suppressor A ATCH	I-15	3	Sensor - Pressure Crankcase	E-3	20
Arc Suppressor B ATCH	I-15	3	Sensor - Pressure Demand Fan	C-6	39
Battery - 1	I-5	4	Sensor - Pressure Engine Oil	E-3	40
Battery - 2	I-5	4	Sensor - Pressure Main Hydraulic Pump Oil	G-13	41
Battery - 3 & 4	C-5	5	Sensor - Pressure Tilt Hydraulic Pump Oil	G-13	41
Block AS - Power	F-6	6	Sensor - Pressure Turbo Inlet LH	E-3	42
Breaker - Blower	H-10	E	Sensor - Pressure Turbo Inlet RH	E-3	43
Breaker - Remote Condenser ATCH	H-10	E	Sensor - Pressure Turbo Outlet	E-3	44
Buss Bar A	G-10	E	Sensor - Ripper Raise / Lower ATCH	G-16	B
Buss Bar B	H-10	E	Sensor - Shank In / Out ATCH	H-16	B
Buss Bar C	H-10	E	Sensor - Speed / Timing	E-3	45
Buss Bar D	G-10	E	Sensor - Speed Torque Converter Output	G-13	36
Control - Actuator	G-1	B	Sensor - Steer Lever Position LH	I-7	C
Control - Engine	E-5	7	Sensor - Steer Lever Position RH	I-7	C
Control - Handle Implement	H-16	B	Sensor - TDC Cal	E-3	46
Control - Handle Ripper ATCH	H-16	B	Sensor - Temperature Aftercooler	F-3	40
Control - Implement	D-15	E	Sensor - Temperature Air Inlet	E-3	47
Control - Monitor (VIDS)	F-14	B	Sensor - Temperature Coolant	E-3	48
Control - Power Train	J-9	B	Sensor - Temperature Exhaust LH	F-3	49
Control - Product Link	G-12	23	Sensor - Temperature Exhaust RH	E-3	39
Control - Shifter	J-7	C	Sensor - Temperature Oil Hydraulic	B-16	50
Control - Temperature ATCH	F-16	B	Sensor - Temperature Oil Power Train	D-3	51
Converter - 24V to 12V 20A ATCH	C-15	11	Sensor - Temperature Oil Steering	I-12	35
Converter - 24V to 12V	F-16	10	Sensor - Ultrasonic Fuel Level	B-16	52
Cord AS - Water Heater LH	F-5	20	Socket - Power Outlet	F-16	34
Cord AS - Water Heater RH	F-5	2	Solenoid - A/C Clutch ATCH	F-3	24
Dimmer	E-8	A	Solenoid - Blade Lower / Float	G-13	G
Diode - Block 1 (Arc Suppressor)	E-1	70	Solenoid - Blade Raise	H-13	G
Diode - Block 2 (Arc Suppressor)	D-1	71	Solenoid - Blade Tilt Left	G-13	G
Diode - Block 3 (Arc Suppressor)	E-1	72	Solenoid - Blade Tilt Right	H-13	G
Display - Gauge Cluster	E-11	A	Solenoid - Brake Dump Parking	H-12	35
Display - Monitor (VIDS) Message Center	D-11	A	Solenoid - Brake Dump Service	H-12	35
Display - Speedometer / Tachometer	E-11	A	Solenoid - Brake Steer LH	H-12	35
Element GP - Water Heater LH	F-6	20	Solenoid - Brake Steer RH	H-12	35
Element GP - Water Heater RH	F-5	2	Solenoid - Clutch First Gear	I-13	D
Fan - Defrost Front ATCH	F-10	13	Solenoid - Clutch Forward	I-13	D
Fan - Defrost Rear ATCH	D-10	14	Solenoid - Clutch Reverse	I-13	D

Machine locations are repeated for components located close together.

A = Located in the dash.

B = Located in or on the right-hand console.

C = Located in the left-hand console.

D = Located in transmission case.

E = Located lower left of the dash.

F = Located at each cylinder of the engine.

G = Located on or around the Electro/Hydraulic Manifold.

H = Located on or in the headliner.

COMPONENT LOCATION

Page 2 of 3



Component	Schematic Location	Machine Location	Component	Schematic Location	Machine Location
Fuse - Alternator	H-10	E	Solenoid - Clutch Second Gear	I-13	D
Fuse Block	G-10	E	Solenoid - Clutch Steer LH	H-12	35
Ground Strap - Engine Control Ground	D-5	7	Solenoid - Clutch Steer RH	H-12	35
Ground Strap 1 (Beam to Frame)	H-5	17	Solenoid - Clutch Third Gear	I-13	D
Ground Strap 2 (LH Fender to Beam)	H-5	6	Solenoid - Demand Fan	D-6	53
Ground Strap 3 (LH Beam to Platform)	H-5	6	Solenoid - Diverter	B-13	36
Ground Strap 4 (RH Beam to RH Fender)	C-6	18	Solenoid - Dual Tilt	H-3	54
Ground Strap 5 (Fuel Tank to LH Fender)	B-16	19	Solenoid - Fan Bypass ATCH	F-6	53
Heater - Jacket Water Left	F-6	20	Solenoid - Implement Lockout	H-13	G
Heater - Jacket Water Right	F-5	2	Solenoid - Injector 1	F-4	F
Horn - Forward High	D-4	21	Solenoid - Injector 2	E-4	F
Horn - Forward Low	D-4	21	Solenoid - Injector 3	F-4	F
Indicator - LED Actuator	E-2	22	Solenoid - Injector 4	E-4	F
Indicator - Operating Function Statistics	C-13	22	Solenoid - Injector 5	F-4	F
Indicator - Strip LED	F-11	E	Solenoid - Injector 6	E-4	F
Keypad - Monitor (VIDS)	D-13	22	Solenoid - Injector 7	F-4	F
Lamp - Backlight Keypad	D-13	22	Solenoid - Injector 8	F-4	F
Lamp - Backlight Panel	F-11	A	Solenoid - Ladder Lower	D-1	75
Lamp - Backlight Washer	B-10	H	Solenoid - Ladder Raise	E-1	75
Lamp - Dash Warning	I-2	B	Solenoid - PCO	G-13	G
Lamp - Master Action	F-11	A	Solenoid - Pitch Regenerate ATCH	H-3	54
Lamp - Master Action Rear	G-15	10	Solenoid - Ripper Pin ATCH	I-15	3
Module - A/C ATCH	G-3	24	Solenoid - Ripper Shank In	H-13	G
Module - Intermittent Front	C-9	H	Solenoid - Ripper Shank Lower	H-13	G
Module - Intermittent Left	C-9	H	Solenoid - Ripper Shank Out	H-13	G
Module - Intermittent Rear	D-10	H	Solenoid - Ripper Shank Raise	G-13	G
Module - Intermittent Right	B-9	H	Solenoid - Start Aid	G-4	24
Motor - Blower ATCH	J-4	9	Switch - A/C On	E-16	B
Motor - Console Raise/Lower	I-7	C	Switch - Accessory	E-10	A
Motor - Defrost Fan Front ATCH	F-10	A	Switch - Bi-Directional Mode	E-11	E
Motor - Defrost Fan Rear ATCH	D-10	26	Switch - Blower	F-16	B
Motor - Pressurizer Group ATCH	F-12	27	Switch - Brake	H-8	56
Motor - Seat Compressor ATCH	G-16	34	Switch - Brake Parking	J-7	C
Motor - Starter 1	I-4	28	Switch - Bypass Electro/Hyd Filter	B-15	57
Motor - Starter 2	H-4	28	Switch - Bypass Fan Return Filter	B-15	58
Motor - Washer Front	J-15	8	Switch - Console Raise / Lower	I-7	C
Motor - Washer Left	J-15	8	Switch - Coolant Flow	D-3	38
Motor - Washer Rear	J-15	8	Switch - Defrost Fan Front ATCH	F-10	A
Motor - Washer Right	J-15	8	Switch - Defrost Fan Rear ATCH	D-10	A
Motor - Wiper Front	C-8	29	Switch - Disconnect	I-6	59
Motor - Wiper Left	C-8	30	Switch - Downshift	I-7	C
Motor - Wiper Rear	D-9	31	Switch - Fan Pump Out Screen	H-1	76
Motor - Wiper Right	B-8	32	Switch - Flood Front	E-10	A

Machine locations are repeated for components located close together.

A = Located in the dash.

B = Located in or on the right-hand console.

C = Located in the left-hand console.

D = Located in transmission case.

E = Located lower left of the dash.

F = Located at each cylinder of the engine.

G = Located on or around the Electro/Hydraulic Manifold.

H = Located on or in the headliner.

COMPONENT LOCATION

Page 3 of 3



Component	Schematic Location	Machine Location	Component	Schematic Location	Machine Location
Plug - Implement Code (D11CD)	D-16	B	Switch - Flood Rear	E-10	A
Plug - Implement Code (D11R)	E-16	B	Switch - Floods Side	E-10	A
Plug - Power Train Code	J-10	9	Switch - Fuel Filter	D-3	53
Radio - Product Link	G-11	23	Switch - Horn	G-15	B
Relay - Actuator and Buzzer Enable	E-1	74	Switch - Implement Lockout	I-16	B
Relay - Intermittent Front	C-8	33	Switch - Intermittent Wiper Front	C-11	H
Relay - Intermittent Left	C-8	33	Switch - Intermittent Wiper Left	C-11	H
Relay - Intermittent Right	C-8	33	Switch - Intermittent Wiper Rear	D-11	H
Relay - Ladder Lower 2	F-1	74	Switch - Intermittent Wiper Right	C-11	H
Relay - Ladder Raise 1	F-1	74	Switch - Key Start	F-10	A
Relay - Latching Actuator 3	F-1	74	Switch - Ladder	D-2	77
Relay - Main	G-10	E	Switch - Load Select ATCH	D-13	44
Relay - Park Brake Switch Pos 6	E-1	74	Switch - Main Pump Out Screen	H-1	78
Relay - Pressurizer Group ATCH	J-12	27	Switch - Power Train Oil Bypass Filter 1	J-12	60
Relay - Raise Sol Cutout 5	E-1	74	Switch - Power Train Oil Bypass Filter 2	J-12	60
Relay - Start 1	G-10	E	Switch - Power Train Oil Temperature	D-3	51
Relay - Start 2	G-10	E	Switch - Pressure A/C High ATCH	G-3	24
Relay - Start Aid	G-5	24	Switch - Pressure A/C Low ATCH	F-3	24
Relay - Start Aid Hold	H-5	24	Switch - Pressure Prelube Oil ATCH	G-5	53
Relay - Wiper Rear	D-10	33	Switch - Prox	F-1	79
Resistor - J1939 Data Link Termination 1	E-14	10	Switch - Reverse	I-8	C
Resistor - J1939 Data Link Termination 2	E-15	10	Switch - Ripper Auto Stow ATCH	G-16	B
Resistor - Motor Blower ATCH	J-14	9	Switch - Ripper Pin Puller ATCH	G-15	B
Resistor - Start Aid	G-5	24	Switch - Seat ATCH	G-16	34
Resistor - Starter Diagnostic 1	H-4	28	Switch - Start Aid	E-10	A
Resistor - Starter Diagnostic 2	H-4	28	Switch - Thermostat ATCH	J-12	9
Resistor - Water Valve Signal ATCH	J-13	9	Switch - Throttle	H-15	B
Sensor - Brake	H-8	35	Switch - Tilt Pump Out Screen	H-1	80
Sensor - Deceleration Pedal	E-9	E	Switch - Upshift	J-7	C
Sensor - Direction	I-7	C	Timer - Prelube ATCH	F-5	24
Sensor - Dynamic Inclination	C-13	G	Valve - Water	J-13	9
Sensor - Ground Speed (Radar)	B-13	36			

Machine locations are repeated for components located close together.

A = Located in the dash.

B = Located in or on the right-hand console.

C = Located in the left-hand console.

D = Located in transmission case.

E = Located lower left of the dash.

F = Located at each cylinder of the engine.

G = Located on or around the Electro/Hydraulic Manifold.

H = Located on or in the headliner.

CONNECTOR LOCATION

Page 1 of 2



Connector Number	Schematic Location	Machine Location
CONN 1	G-16	B
CONN 2	F-16	B
CONN 3	F-16	B
CONN 4	E-16	B
CONN 5	D-16 , E-16	B
CONN 6	B-16	41
CONN 7	C-15	10
CONN 8	E-15	10
CONN 9	I-15	3
CONN 10	J-15	61
CONN 11	J-15	26
CONN 12	I-15	26
CONN 13	H-14	27
CONN 14	H-14	62
CONN 15	E-14	10
CONN 16	E-14	10
CONN 17	C-14	62
CONN 18	C-14	22
CONN 19	D-14	22
CONN 20	D-14	22
CONN 21	J-13	9
CONN 22	J-12	63
CONN 23	I-12	E
CONN 24	D-12	58
CONN 25	C-12	58
CONN 26	C-12	58
CONN 27	H-11	E
CONN 28	I-10	33
CONN 29	I-10	33
CONN 30	G-10	E
CONN 31	G-10	E
CONN 32	F-10	E
CONN 33	D-10	31
CONN 34	C-10	62

The connectors shown in this chart are for harness to harness connectors. Connectors that join a harness to a component are generally located at or near the component. See the Component Location Chart.

CONNECTOR LOCATION

Page 2 of 2



Connector Number	Schematic Location	Machine Location
CONN 35	C-10	62
CONN 36	D-10	A
CONN 37	J-10	9
CONN 38	G-9	A
CONN 39	F-9	A
CONN 40	D-8	A
CONN 41	D-8	A
CONN 42	D-8	A
CONN 43	C-9	H
CONN 44	H-7	56
CONN 45	D-7	24
CONN 46	D-7	24
CONN 47	C-7	24
CONN 48	B-6	18
CONN 49	E-6	65
CONN 50	D-6	38
CONN 51	E-6	65
CONN 52	F-6	63
CONN 53	F-6	63
CONN 54	G-6	17
CONN 55	G-6	63
CONN 56	G-6	24
CONN 57	J-6	17
CONN 58	C-4	66
CONN 59	C-4	66
CONN 60	G-4	44
CONN 61	G-4	67
CONN 62	I-4	12
CONN 63	J-4	68
CONN 64	J-3	68
CONN 65	H-2 , I-1	B
CONN 66	E-2	B

The connectors shown in this chart are for harness to harness connectors. Connectors that join a harness to a component are generally located at or near the component. See the Component Location Chart.

Component Identifiers (CID ¹) Module Identifier (MID ²)	
Engine Control (MID No. 036)	
CID	Component
0001	Cylinder 1 Injector Solenoid
0002	Cylinder 2 Injector Solenoid
0003	Cylinder 3 Injector Solenoid
0004	Cylinder 4 Injector Solenoid
0005	Cylinder 5 Injector Solenoid
0006	Cylinder 6 Injector Solenoid
0007	Cylinder 7 Injector Solenoid
0008	Cylinder 8 Injector Solenoid
0091	Throttle Switch
0100	Oil Pressure Sensor
0101	Crankcase Pressure Sensor
0110	Coolant Temperature Sensor
0168	Electrical Power Supply
0190	Engine Speed Signal
0248	Cat Data Link
0253	Personality Module
0254	Engine ECM
0261	Speed / Timing Sensor
0262	5 Volt Sensor DC Power Supply
0263	Digital Sensor Supply
0264	Decelerator Position Sensor
0266	Crank Without Inject Inputs
0268	Programmable Parameters
0273	Turbocharger Outlet Pressure Sensor
0274	Atmospheric Pressure Sensor
0275	Right Turbocharger Inlet Pressure Sensor
0276	Left Turbocharger Inlet Pressure Sensor
0277	Timing Calibration
0290	Engine Cooling Fan Pressure Sensor
0291	Engine Fan Control Solenoid
0545	Start Aid Relay
0546	Start Aid Hold Relay
0827	Left Exhaust Temperature Signal
0828	Right Exhaust Temperature Signal
0829	Rear Aftercooler Temperature Signal
0861	Service Engine Lamp
0865	High Exhaust Temperature Lamp
0867	Hydraulic Engine Retarder Valve
Monitor (VIDS) (MID No. 051)	
CID	Component
96	Fuel Level Sensor
271	Action Alarm
296	Power Train ECM
324	Master Action Lamp
590	Engine ECM
596	Implement ECM
600	Hydraulic Oil Temperature Sensor
809	Speedometer / Tachometer
811	Gauge (Quad) Cluster
815	Message Center
820	Keypad Data Link
1045	Power Train Oil Temperature Sensor
1426	Rear Master Action Lamp

Power Train Control (MID No. 113)	
CID	Component
70	Parking Brake Switch - On / Off Pole
75	Steering System Oil Temperature Sensor
168	Electrical System
177	Transmission Oil Temperature Sensor
190	Engine Speed Sensor
248	Cat Data Link
254	Power Train Control
269	Sensor Power Supply
298	Service Brake Switch
299	Transmission Direction Lever Position Sensor
368	Autoshift Switch
468	Service Brake Pedal Position Sensor
573	Inching Pedal Position Sensor
618	Parking Brake Switch - Brake Backup Pole
621	Downshift Switch
622	Upshift Switch
623	Direction Switch
650	Harness Code
668	Transmission Lever Position Sensor
671	Transmission Output Speed 1 Sensor
672	Torque Converter Output Speed Sensor
673	Transmission Output Speed 2 Sensor
674	Transmission Intermediate Speed 1 Sensor
675	Transmission Intermediate Speed 2 Sensor
676	Left Steering Lever Position Sensor
677	Right Steering Lever Position Sensor
681	Parking Brake Solenoid
689	Left Steering Brake Solenoid
690	Right Steering Brake Solenoid
691	Reverse Clutch Solenoid Valve 1
692	Forward Clutch Solenoid Valve 2
693	Speed 3 Clutch Solenoid Valve 3
694	Speed 2 Clutch Solenoid Valve 4
695	Speed 1 Clutch Solenoid Valve 5
697	Priority Solenoid Valve
698	Left Steering Clutch Solenoid Valve
699	Right Steering Clutch Solenoid Valve
722	Secondary Brake Solenoid Valve
1199	Vital Information Display System (VIDS)

¹ The CID is a diagnostic code that indicates which circuit is faulty.

² The MID is a diagnostic code that indicates which electronic control module diagnosed the fault.

Implement Control (MID No. 082)	
CID	Component
78	Blade Pitch Not Reset
84	Ground Speed Sensor
168	Electrical System Voltage
296	Power Train ECM
490	Implement Lockout Switch
497	Blade Tilt Right Solenoid Valve
498	Blade Tilt Left Solenoid Valve
590	Engine ECM
596	Implement ECM
597	Main Pump Pressure Sensor
650	Harness Code
672	Torque Converter Output Speed Sensor
869	Right Lift Cylinder Position Sensor (CDO)
870	Left Lift Cylinder Position Sensor (CDO)
871	Inclination Sensor
873	Tilt Pump Pressure Sensor
874	Mode Select Switch
875	Manual Select Switch
876	Pitch Forward Trigger Switch
877	Pitch Back Thumb Switch
878	Load Selector
879	Ripper Shank In / Out Sensor
880	Ripper Raise / Lower Sensor
881	Ripper Auto Stow Switch
882	Implement Lockout Solenoid Valve
883	Pitch Regenerate Solenoid Valve
884	Pitch Solenoid of Dual Tilt Solenoid Valve
885	Pressure Compensation Override Solenoid Valve
886	Ripper Shank In Solenoid Valve
887	Ripper Shank Out Solenoid Valve
888	Ripper Shank Lower Solenoid Valve
889	Ripper Shank Raise Solenoid Valve
1034	Pitch Forward Thumb Switch
1047	Single Tilt Solenoid of Dual Tilt Solenoid Valve
1078	Blade Control Lift Sensor
1079	Blade Control Tilt Sensor
1180	Auxiliary Solenoid #1
1197	Blade Lower Solenoid Valve
1198	Blade Raise Solenoid Valve
1199	Vital Information Display System (VIDS)
1298	Solenoid Calibration (Implement ECM Replaced)
1395	Engine Over Speed
1448	Torque Converter Output Speed (Power Train ECM)
1709	Diverter Solenoid

Failure Mode Identifiers (FMI) ¹	
FMI No.	Failure Description
0	Data valid but above normal operational range.
1	Data valid but below normal operational range.
2	Data erratic, intermittent, or incorrect.
3	Voltage above normal or shorted high.
4	Voltage below normal or shorted low.
5	Current below normal or open circuit.
6	Current above normal or grounded circuit.
7	Mechanical system not responding properly.
8	Abnormal frequency, pulse width, or period.
9	Abnormal update.
10	Abnormal rate of change.
11	Failure mode not identifiable.
12	Bad device or component.
13	Out of calibration.
14	Parameter failures.
15	Parameter failures.
16	Parameter not available.
17	Module not responding.
18	Sensor supply fault.
19	Condition not met.
20	Parameter failures.

¹The FMI is a diagnostic code that indicates what type of failure has occurred.

Resistor and Solenoid Specifications		
Part No.	Component Description	Resistance (Ohms) ¹
3E-7842	Resistor: Starter Diagnostic 1 Starter Diagnostic 2	150 ± 7.5
125-9740	Resistor: Blower Motor	A - C 2.0 ± 5% B - C 1.0 ± 5% C - D 0.36 ± 5%
134-2540	Resistor: J1939 Data Link Termination 1 J1939 Data Link Termination 2	120
239-9368	Resistor: Water Valve Signal	27.0 k ± 1%
3E-1906	Solenoid: A/C Clutch	17.6 ± 0.6
3E-8575	Solenoid: Ripper Pin	25
3E-9205	Solenoid: Dual Tilt	25
121-4030	Solenoid: LH Steer Brake LH Steer Clutch RH Steer Brake RH Steer Clutch	7.75 ± 1.0
124-3052	Solenoid: Blade Lower / Float Blade Raise Blade Tilt Left Blade Tilt Right Ripper Raise Ripper Shank In Ripper Shank Lower Ripper Shank Out	7.75 ± 1.0
147-5399	Solenoid: 1st Gear Clutch 2nd Gear Clutch 3rd Gear Clutch Forward Clutch Reverse Clutch	8.15 ± 0.6
149-2610	Solenoid: Fan Bypass	32.6 ± 1.6
152-6761	Solenoid: Implement Lockout	32.6 ± 1.6
152-8340	Solenoid: PCO	32.6 ± 1.6
152-8346	Solenoid: Pitch Regenerate	32.6 ± 1.6
155-4066	Solenoid: Injectors 1 - 8	0.060 ± 5%
172-2392	Solenoid: Park Brake Dump Service Brake Dump	41.9 ± 2.1
189-0189	Solenoid: Diverter	32.6 ± 1.6
189-8627	Solenoid: Demand Fan	5.0 ± 0.3

¹ At room temperature unless otherwise noted.

Off Machine Switch Specification				
Part No.	Function	Actuate	Deactuate	Contact Position
3E-5464	Refrigerant Thermostat	-1.1 ± 0.8°C (30 ± 1.4°F)	2.2 ± 0.8°C (36 ± 1.4°F)	Normally Closed
3E-9350	Power Train Oil Temperature	52.0 ± 3.0° C (125.6 ± 5.4° F)	43° C MIN (109.4° F MIN)	Normally Closed
105-9152	Pre-lube Oil Pressure	30 ± 7 kPa (4.4 ± 1)	30 ± 7 kPa (4.4 ± 1)	Normally Closed
114-5333	Refrigerant Pressure (A/C)	275 to 1750 kPa ¹ (40 to 255 psi)	--	Normally Open ²
255-2282	Fuel Filter	137.9 ± 13.8 kPa (20 ± 2 psi)	87.2 kPa MIN (12 psi MIN)	Normally Closed
149-6371	A/C Low Pressure	103.4 ± 13.8 kPa (15 ± 2 psi)	34.5 ± 7 kPa (5 ± 1 psi)	Normally Open
156-1382	Electro/Hyd Filter Bypass	276 ± 28 kPa (40 ± 4 psi)	179 kPa MIN (26 psi MIN)	Normally Closed
171-8708	Coolant Flow	362 ± 29 mN (1.3 ± .1 oz.)	303 mN MIN (1.1 oz. MIN)	Normally Open

¹ With increasing pressure the closed condition can be maintained up to 2800 kpa (405 psi), with decreasing pressure the closed condition can be maintained down to 170 kpa (25psi).

² Contact position at the contacts of the harness connector.

Related Electrical Service Manuals		
Title		Form Number
3508B Engines for Caterpillar Built Machines:		REN1331
50-MT Series Starting Motors:	6V-0890, 123-8689	SEN3860
Contour Series Seat:		SEN6615
HDB Series and M1 Series Heavy Duty Brushless Alternators:	197-8820	SEN4130
Implement Control:		SEN9457
Monitor (VIDS)		SEN9413
Power Train Control:		REN3695
Starting and Charging Systems:		SEN2947

WIRE DESCRIPTION

Page 1 of 3



Wire Number	Wire Color	Description	Wire Number	Wire Color	Description
Power Circuits			Control Circuits Continued		
101	RD	Battery (+)	A705	YL	Injector #5
102	RD	Head Lamp	A706	GY	Injector #6
105	RD	Key Switch	A707	PU	Injector #7
108	BU	Auxiliary Circuit	A708	BR	Injector #8
109	RD	Alternator Output (+) Terminal	A746	PK	Turbo Outlet Pressure
112	PU	Main Power Relay Output	A747	GY	Atmospheric Pressure
113	OR	Operator Monitor Panel VMIS B+ Switched	A751	YL	Aftercooler Temperature
114	RD	Warning Horn (Forward)	C567	YL	Right Rear Speaker (Common)
115	PK	Auxiliary Circuit	C568	WH	Blower Motor (Max)
116	BR	Rear Flood Switch	C569	YL	Second DC/DC Converter Power Output
122	BU	A/C Clutch	C708	PU	Ladder Switch
124	GN	Auxiliary Circuit	C709	WH	Ladder Switch
125	OR	Side Floods Switch	C738	BU	Ladder Lower Switch
130	GN	Fuse Block	C743	PK	Ladder Alarm
131	RD	Fuse Block	C756	BU	Ladder Raise Solenoid
133	OR	Fuse Block	C797	YL	Height Up Switch to Height Adjust Motor
134	YL	Fuse Block	C798	GN	Height Down Switch to Height Adjust Motor
135	RD	VIDS Control ECM	C913	BU	AWD Ground Speed (Radar)
139	OR	Auxiliary Circuit	C989	PU	Oil Level
140	BU	Brake Sensor	E455	BR	Hydraulic Oil Filter
150	RD	Battery (+)	E508	PK	Front Wiper Switch to Front Intermittent Module
158	BR	Remote Condenser	E509	PU	Front Intermittent Wiper Module to Front Wiper
174	PK	Accessory Switch	E510	GN	Rear Wiper Switch to Rear Intermittent Module
176	YL	Fuse Block	E511	WH	Rear Intermittent Wiper Module to Rear Wiper
184	BU	Ripper Pin Puller	E512	OR	Right Wiper Switch to Right Intermittent Module
186	RD	Auxiliary Circuit	E513	BR	Right Intermittent Wiper Module to Right Wiper
197	GN	Auxiliary Circuit	E514	YL	Left Wiper Switch to Left Intermittent Module
198	RD	Implement ECM	E515	PK	Left Intermittent Wiper Module to Left Wiper
Ground Circuits			E516	YL	Front Intrmnt Relay to Front Wiper Motor Park
200	BK	Main Chassis	E517	PU	Rear Intrmnt Relay to Rear Wiper Motor Park
201	BK	Operator Monitor Return	E518	BU	Right Intrmnt Relay to Right Wiper Motor Park
202	BK	Transmission Control	E519	GN	Left Intrmittent Relay to Left Wiper Motor Park
207	BK	Starter Diagnostic	E552	GY	Power to Actuator Relay
210	BK	Converter Output (24/12 Volt)	E553	GN	Power to Actuator Relay
229	BK	Battery (-)	E562	PU	Ladder Raise Relay 1
270	BK	CMS Indent. Code 0	E707	GN	VMIS Display +V
271	BK	CMS Indent. Code 1	E708	PK	VMIS Display Clock
272	BK	CMS Indent. Code 2	E710	BU	VMIS LCD Lamp Driver
273	BK	CMS Indent. Code 3	E735	PU	Smart EMS Tach. / Serv Mtr. / Odometer Select
274	BK	CMS Indent. Code 4	E793	BU	ATA Data Link -
275	BK	CMS Indent. Code 5	E794	YL	ATA Data Link +
276	BK	Transmission Control Indent. Code 0	E795	YL	Crankcase Pressure
277	BK	Transmission Control Indent. Code 1	E796	GN	Inlet Air Temperature Sensor
278	BK	Transmission Control Indent. Code 2	E797	WH	PWM #3 Return
279	BK	Transmission Control Indent. Code 3	E798	PK	PWM #3
280	BK	Transmission Control Indent. Code 4	E799	BR	PWM #1 and #2 Return
290	BK	CMS Service	E900	WH	ECPC Transmission Output Speed +
291	BK	CMS Clear	E901	GN	ECPC Transmission Output Speed -
Basic Machine Circuits			E902	PU	ECPC Transmission Intermediate Speed +
301	BU	Starter No. 1 Solenoid	E903	YL	ECPC Transmission Intermediate Speed -
302	OR	Starter No. 1 Resistor to Diagnostic	E904	BR	ECPC Transmission Intermediate Speed Q+
304	WH	Starter Relay No. 1 Output	E905	BU	ECPC Transmission Intermediate Speed Q-
306	GN	Starter Relay Coil to Neutral Start Sw or Key Sw	E906	OR	ECPC Transmission Output Speed Q+
307	OR	Key Sw to Neut Start Sw or VMIS Snr Module	E907	GY	ECPC Transmission Output Speed Q-
308	YL	Main Power Relay Coil	E908	BR	ECPC Transmission Input Speed +
310	PU	Start Aid Switch to Start Aid Solenoid	E909	WH	ECPC Transmission Input Speed -
312	PK	Starter No. 2 Solenoid to Resistor	E917	WH	Implement Lockout Switch to Ground (N.O.)
313	GY	Starter No. 2 Resistor to Diagnostic	E918	GN	Implement Lockout Switch to Ground (N.C.)
314	PU	Starter Relay No. 2 Output	F701	BR	PWM #2 Out (3.5A)
321	BR	Backup Alarm Lamp Travel Alarm	F702	GN	Throttle
322	GY	Warning Horn (Forward)	F703	GY	LH Turbine Inlet Exhaust Temperature
334	BU	Start Aid Solenoid #2	F704	OR	RH Turbine Inlet Exhaust Temperature
337	WH	Prelube Push Button Switch to Prelube Timer	F707	WH	Start Aid Current Level Relay

WIRE DESCRIPTION

Page 2 of 3



Wire Number	Wire Color	Description	Wire Number	Wire Color	Description
Monitoring Circuits			Control Circuits Continued		
403	GN	Alternator (R) Terminal	F710	BR	Start Aid On Relay
410	WH	Operator Monitor Action Alarm	F711	GN	CAN Link +
411	PK	Operator Monitor Master	F712	GY	CAN Link -
412	BU	Operator Monitor Cool Flow/DS2	F713	OR	Left Turbo Inlet Pressure
419	YL	Operator Monitor Parking Brake	F714	PK	Right Turbo Inlet Pressure
421	BU	Operator Monitor Fault Lamp (Scraper)	F715	PU	Shutdown (N.O.)
426	BR	Operator Monitor Power Train Oil Filter	F716	WH	Shutdown (N.C.)
427	GN	Operator Monitor Power Train Oil Filter Jumper	F717	YL	Switch 4
442	GY	Hydraulic System Temperature Gage	F718	BU	Switch 5
443	YL	Power Train Temperature Gage	F719	BR	Switch 6/1
447	PK	Fuel Level Gage	F720	GN	Switch 8/3
450	YL	Tachometer Sender (+)	F721	GY	Switch 9/4
471	PK	Transmission Neutral to Parking Brake	F723	PK	TDC Probe +
499	GY	Fan Return Filter Bypass Switch	F724	PU	TDC Probe -
A210	BK	Linkage Control Harness Code 0	F725	WH	Demand Fan Pressure
A211	BK	Linkage Control Harness Code 1	F726	YL	Injector Common 1 & 3
A212	BK	Linkage Control Harness Code 2	F727	YL	Injector Common 2 & 4
A213	BK	Linkage Control Harness Code 3	F728	BR	Injector Common 5 & 7
A404	BU	Fan Pump Out Screen	F729	GN	Injector Common 6 & 8
A447	PK	Prelube Pressure Switch to Prelube Timer	F737	YL	Analog Sensor Input 6
C413	YL	VMIS Display Data	F780	PK	Parking Brake Switch
C414	BU	VMIS Display Load	F781	BR	Downshift Switch (N.O.)
C415	WH	VMIS Display Key Data	F782	OR	Reverse Switch (N.O.)
C436	WH	Tilt Pump Out Screen	F783	GN	Upshift Switch (N.C.)
C445	BU	Diode Block 1, 3	F784	YL	Downshift Switch (N.C.)
C471	GN	Relay Contact to Indicator Lamp	F785	WH	Upshift Switch (N.O.)
Accessory Circuits			F786	GY	Reverse Switch (N.C.)
500	BR	Wiper - Front (Park)	F789	YL	Right Steer Clutch
501	GN	Wiper - Front (Low)	F790	BR	Service Brake Pedal
502	OR	Wiper - Front (High)	F791	BU	Right Brake Solenoid
503	BR	Wiper - Rear (Park)	F792	WH	Left Brake Solenoid
504	YL	Wiper - Rear (Low)	F797	BU	Display Sensor +V
505	BU	Wiper - Rear (High)	F799	BU	Implement Control System Dump Valve
506	PU	Washer - Front	F842	BU	AIH Post Heat
507	WH	Washer - Rear	F843	YL	Inching Pedal
508	PU	Radio Speaker - Left	F846	PU	LED Driver 1
509	WH	Radio Speaker - Left (Common)	F847	YL	ECB Switch LP 1
511	BR	Radio Speaker - Right	F848	OR	ECB Switch LP 2
512	GN	Radio Speaker - Right (Common)	F849	WH	ECB Switch LP 3
513	GN	A/C Compressor / Refrigerant Pressure Switch	F850	PK	ECB Switch LP 4
515	GY	Blower Motor (High)	G730	PK	EPTC LI - Park Brake Solenoid
516	GN	Blower Motor (Medium)	G731	GY	EPTC LI - Secondary Service Brake Solenoid
517	BU	Blower Motor (Low)	G848	GN	LED Driver 2
519	GN	Thermostat to Refrigerant Pressure Switch	G865	BU	12v+ Switch Power
521	YL	A/C Switch to Refrigerant Switch	G939	PK	MAC14 Switch Return
522	WH	A/C Clutch to Thermostat Switch	H448	BR	Main Pump Out Screen
523	BR	Wiper - Left (Park)	H710	PK	Implement Control Lift Lever Position
524	BU	Wiper - Left (Low)	H711	GN	Implement Control Tilt Lever Position
525	GY	Wiper - Left (High)	H713	PK	Implement Control Lift Proportional Solenoid
526	YL	Wiper - Right (Park)	H714	OR	Implement Control Lower Proportional Solenoid
527	GN	Wiper - Right (Low)	H721	OR	Implement Control Load Mode Switch
528	PK	Wiper - Right (High)	H735	GY	Driver Signal 1
529	WH	Washer - Left	H746	YL	Fan Control Solenoid Positive
530	OR	Washer - Right	H801	PU	Proportional Driver Return (1-4)
567	WH	A/C Switch Jumper	H802	GY	Proportional Driver Return (5-8)
592	BU	DC/DC Converter Power Output	H803	BU	Proportional Driver Return (9-12)
599	YL	MG Side Shift Solenoid	H804	GN	Proportional Driver Return (13-16)
A513	PK	DC/DC Converter Memory Output	H805	BR	Proportional Driver Return (17-20)

WIRE DESCRIPTION

Page 3 of 3



Wire Number	Wire Color	Description	Wire Number	Wire Color	Description
Lighting Circuits			Control Circuits Continued		
600	BR	Dash Lamp Basic	H806	OR	Proportional Driver Return (21-25)
608	GN	Flood Lamp - Rear	J764	BR	Switch / Sensor Return #1
609	YL	Flood Lamp - Side	J767	GY	Screen Bypass Switches
610	OR	Head Lamp Basic	J910	OR	Cylinder Protection Valve
630	GY	Flood Lamp Rear	J913	GN	Ripper In Valve
633	BU	Attach Lighting Circuit	J914	PU	Ripper Lower Valve
661	GN	Tachometer Lamp - Smart EMS	J921	PK	Ripper Lift Valve
662	YL	Speedometer Lamp - Smart EMS	J922	GY	Ripper Out Valve
663	GY	Gage Lamps - Smart EMS	J929	YL	Ripper Auto-lift Switch (N.C.)
Control Circuits			J930	PK	Ripper Auto-lift Switch (N.O.)
709	OR	Sensor Power Supply	J943	GN	Implement Mode Switch (N.O.)
751	GN	Transmission Shift Solenoid No. 1 or 3	J944	BU	Implement Mode Switch (N.C.)
752	YL	Transmission Shift Solenoid No. 2	J945	WH	Implement Manual Mode Switch (N.O.)
754	BU	Transmission Shift Solenoid No. 3 or 1	J946	OR	Implement Manual Mode Switch (N.C.)
755	OR	Transmission Shift Solenoid No. 4 or 5	J947	YL	Ripper In / Out
779	WH	Coupler Engage Solenoid	J948	PK	Ripper Lift / Lower
780	PU	Coupler Disengage Solenoid	J949	GY	Right Lift Cylinder Position
828	WH	Hydrostatic Left Steer Pedal Sensor	J950	PU	Left Lift Cylinder Position
830	OR	Hydrostatic Right Steer Pedal Sensor	J991	OR	Quick Dump Switch (N.O.)
851	WH	Hydrostatic Speed and Direction Sensor	J996	BR	Quick Dump Switch (N.C.)
892	BR	VMIS Start Mod Right (-) Port/Cat Data Link (-)	J997	GN	Implement LED Driver 3
893	GN	VMIS Start Mod Right (+) Port/Cat Data Link (+)	J998	BU	Implement LED Driver 2
900	PU	Transmission Shift Solenoid No. 5 or 4	J999	WH	Implement LED Driver 1
918	OR	Engine Overspeed Light and Horn	K977	PK	ECPC Transmission Oil Temperature Sensor
924	GN	Transmission Solenoid No. 4 or 5 Return	K978	BU	ECPC Pump Solenoid
973	BR	Coast Autoshift - Auto / Manual Switch 2	K984	GY	Start Aid Timer Output
975	WH	Coast Autoshift - Solenoid Return	M916	OR	Ripper Valve
977	YL	Coast Autoshift - Auto / Manual Switch 1	M919	BU	Ripper Pressure
993	BR	Analog Sensor Common	M921	BR	Tilt Pump Pressure
994	GY	Engine Oil Pressure	M927	GN	Implement Cutout Valve
995	BU	Coolant Temperature	M928	BU	Right Tilt Valve
996	GN	Engine Speed / Timing Sensor Power	M929	WH	Left Tilt Valve
997	OR	Analog Sensor Power (+ 5v)	M930	PK	Pitch Valve
998	BR	Digital Sensor Return	M931	YL	Implement Sensor Supply
999	WH	Primary Camshaft Speed / Timing	N932	PU	Implement LED Driver 4
A523	PU	Temperature Potentiometer Pos 1	N935	OR	Blade Rack Back Switch (N.O.)
A524	BR	Temperature Potentiometer Pos 2	N936	YL	Blade Rack Back Switch (N.C.)
A525	GN	Temperature Potentiometer Pos 3	N937	PU	Blade Dump Switch (N.O.)
A700	OR	Digital Sensor Power (+8v)	N938	BU	Blade Dump Switch (N.C.)
A701	GY	Injector #1	N957	PK	RXD - Comm. #1
A702	PU	Injector #2	N960	OR	TXD - Comm. #1
A703	BR	Injector #3	N970	YL	DTR - Comm. #1
A704	GN	Injector #4	N973	BR	DCD - Comm. #1
			N979	GN	Signal Ground - Comm. #1
			8411	PK	Actuator and Buzzer Enable Relay

HARNESS and WIRE

Electrical Schematic Symbols



Symbols

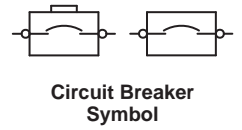
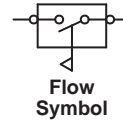
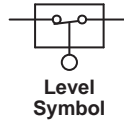
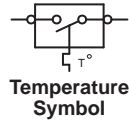
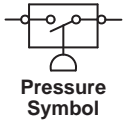

Symbols and Definitions



Fuse: A component in an electrical circuit that will open the circuit if too much current flows through it.

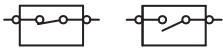

Switch (Normally Open): A switch that will close at a specified point (temp, press, etc.). The circle indicates that the component has screw terminals and a wire can be disconnected from it.

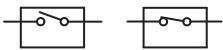

Switch (Normally Closed): A switch that will open at a specified point (temp, press, etc.). No circle indicates that the wire cannot be disconnected from the component.

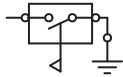

Ground (Wired): This indicates that the component is connected to a grounded wire. The grounded wire is fastened to the machine.

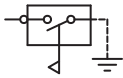

Ground (Case): This indicates that the component does not have a wire connected to ground. It is grounded by being fastened to the machine.

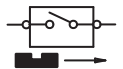

Reed Switch: A switch whose contacts are controlled by a magnet. A magnet closes the contacts of a normally open reed switch; it opens the contacts of a normally closed reed switch.

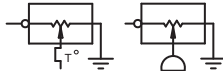

Sender: A component that is used with a temperature or pressure gauge. The sender measures the temperature or pressure. Its resistance changes to give an indication to the gauge of the temperature or pressure.

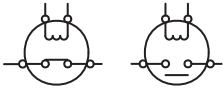

Relay (Magnetic Switch): A relay is an electrical component that is activated by electricity. It has a coil that makes an electromagnet when current flows through it. The electromagnet can open or close the switch part of the relay.

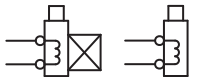

Solenoid: A solenoid is an electrical component that is activated by electricity. It has a coil that makes an electromagnet when current flows through it. The electromagnet can open or close a valve or move a piece of metal that can do work.

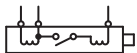

Magnetic Latch Solenoid: A magnetic latch solenoid is an electrical component that is activated by electricity and held latched by a permanent magnet. It has two coils (latch and unlatch) that make electromagnet when current flows through them. It also has an internal switch that places the latch coil circuit open at the time the coil latches.

Harness and Wire Symbols

Wire, Cable, or Harness Assembly Identification: Includes Harness Identification Letters and Harness Connector Serialization Codes (see sample).

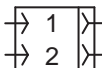
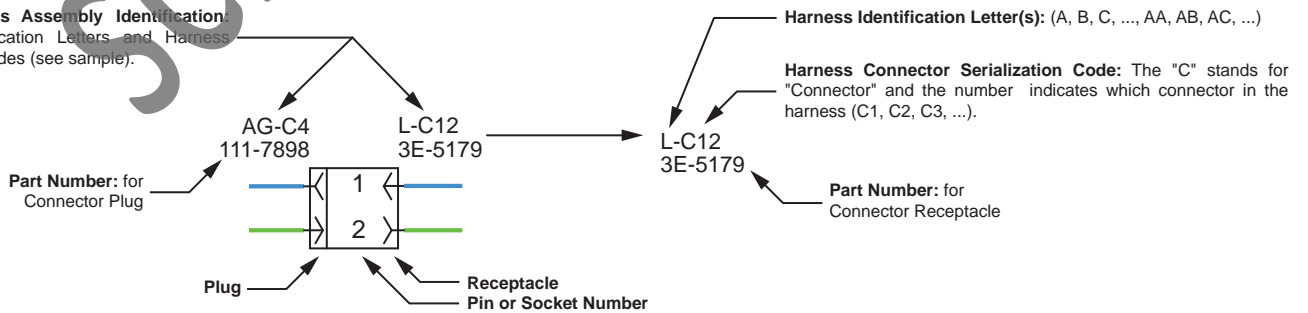

Deutsch connector: Typical representation of a Deutsch connector. The plug contains all sockets and the receptacle contains all pins.

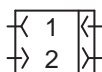

Sure-Seal connector: Typical representation of a Sure-Seal connector. The plug and receptacle contain both pins and sockets.

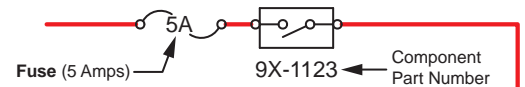

Harness identification code: This example indicates wire group 325, wire 135 in harness "AG".

Wire Gauge

Wire Color

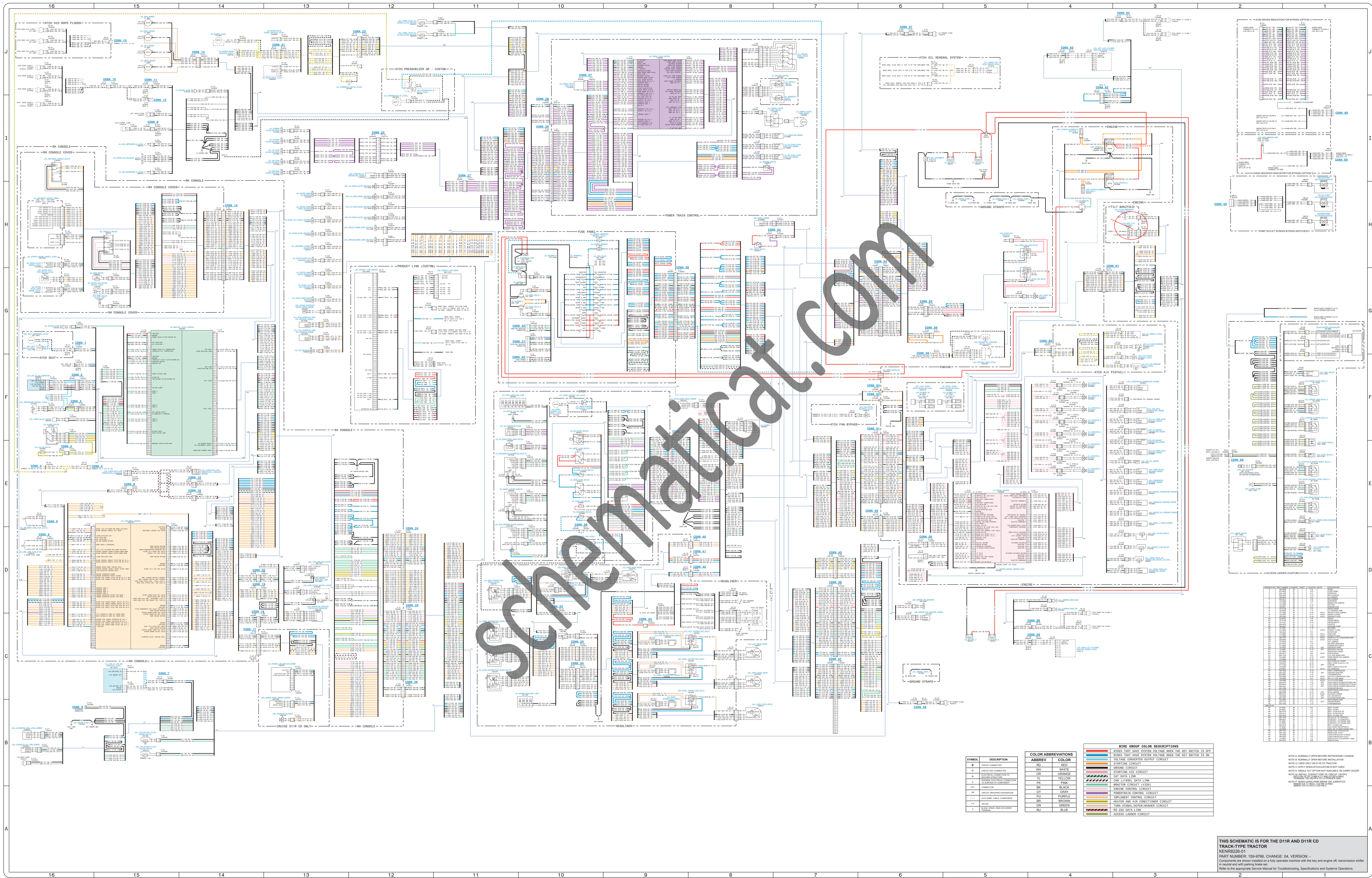

Schematics.com

SYMBOL	DESCRIPTION	ABBREVIATION	COLOR
+	CIRCUIT CONNECTED	RED	RED
+	CIRCUIT NOT CONNECTED	WHITE	WHITE
+	20 AMP FUSE	OR	ORANGE
+	30 AMP FUSE	YL	YELLOW
+	40 AMP FUSE	PK	PINK
+	50 AMP FUSE	BLK	BLACK
+	60 AMP FUSE	GRY	GRAY
+	75 AMP FUSE	PLU	PURPLE
+	100 AMP FUSE	BRN	BROWN
+	150 AMP FUSE	GRN	GREEN
+	200 AMP FUSE	BLU	BLUE

WIRE GROUP COLOR DESCRIPTIONS	DESCRIPTION
RED	WIRING THAT HAVE SYSTEM VOLTAGE WHEN THE KEY SWITCH IS OFF
ORANGE	VOLTAGE CONVERTER OUTPUT CIRCUIT
YELLOW	STARTING CIRCUIT
PINK	STARTING AID CIRCUIT
BLACK	STARTING AID CIRCUIT
GRAY	CAT DATA LINK
PURPLE	CAN LATERAL DATA LINK
BROWN	MONITOR CIRCUIT (VIDS)
GREEN	ENGINE CONTROL CIRCUIT
BLUE	POWERTRAIN CONTROL CIRCUIT
WHITE	OPERATOR CONTROL CIRCUIT
BROWN	HEATER AND AIR CONDITIONER CIRCUIT
GREEN	TIRE SIGNAL/DEFLECTOR CIRCUIT
BLUE	RS-232 DATA LINK
YELLOW	ACCESS LINDER CIRCUIT

THIS SCHEMATIC IS FOR THE D11R AND D11R CD TRACK-TYPE TRACTOR
 PART NUMBER: 159-9766, CHANGE 04, VERSION -
 Components are shown installed on a fully operate machine with the key and engine off, transmission in full in neutral and with parking brake set.
 Refer to the appropriate Service Manual for Troubleshooting, Specifications and Systems Operators.

MACHINE HARNESS CONNECTOR AND COMPONENT LOCATIONS

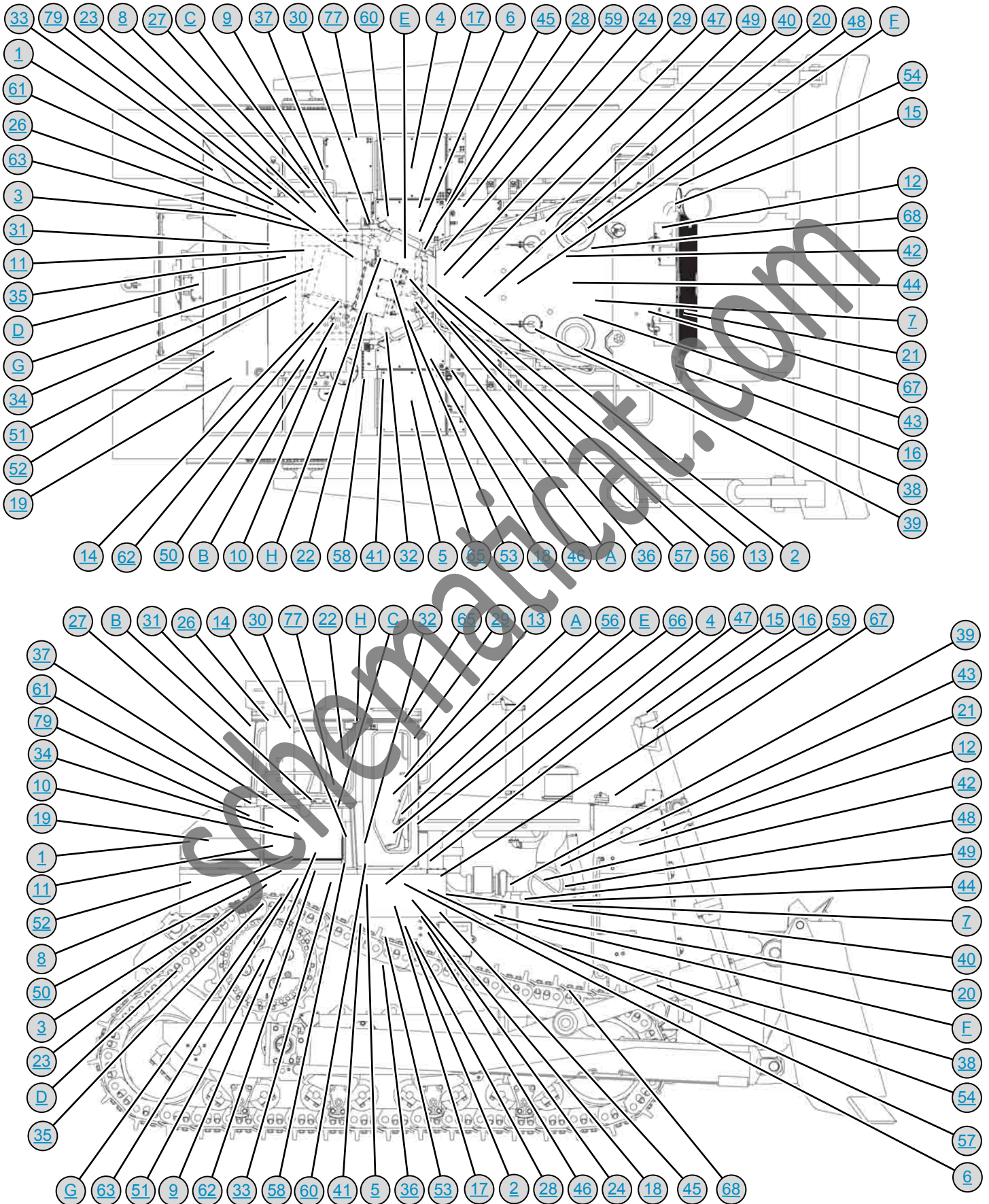

RIPPER, BLADE AND IMPLEMENT SOLENOIDS

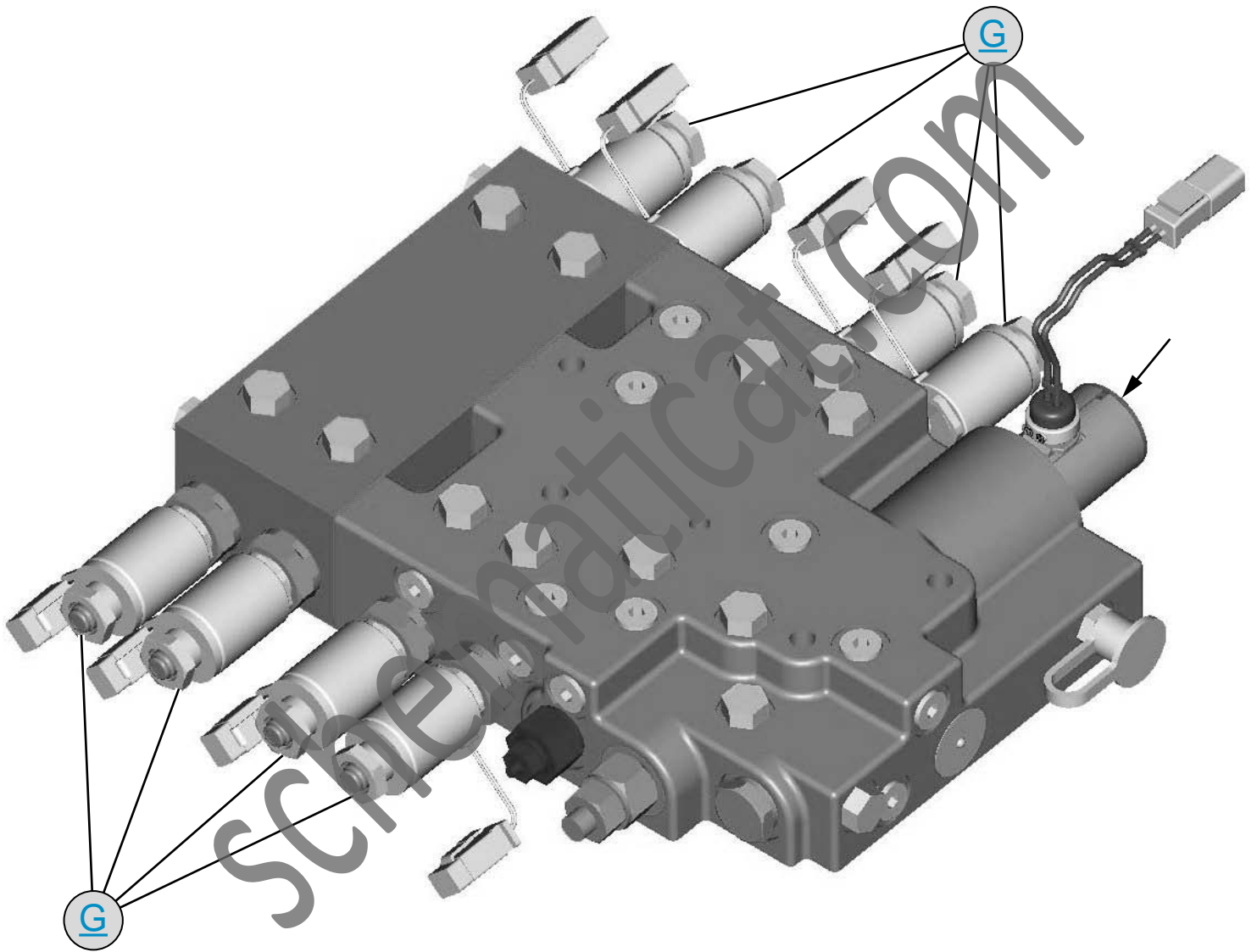

SCREEN GP - HYDRAULIC

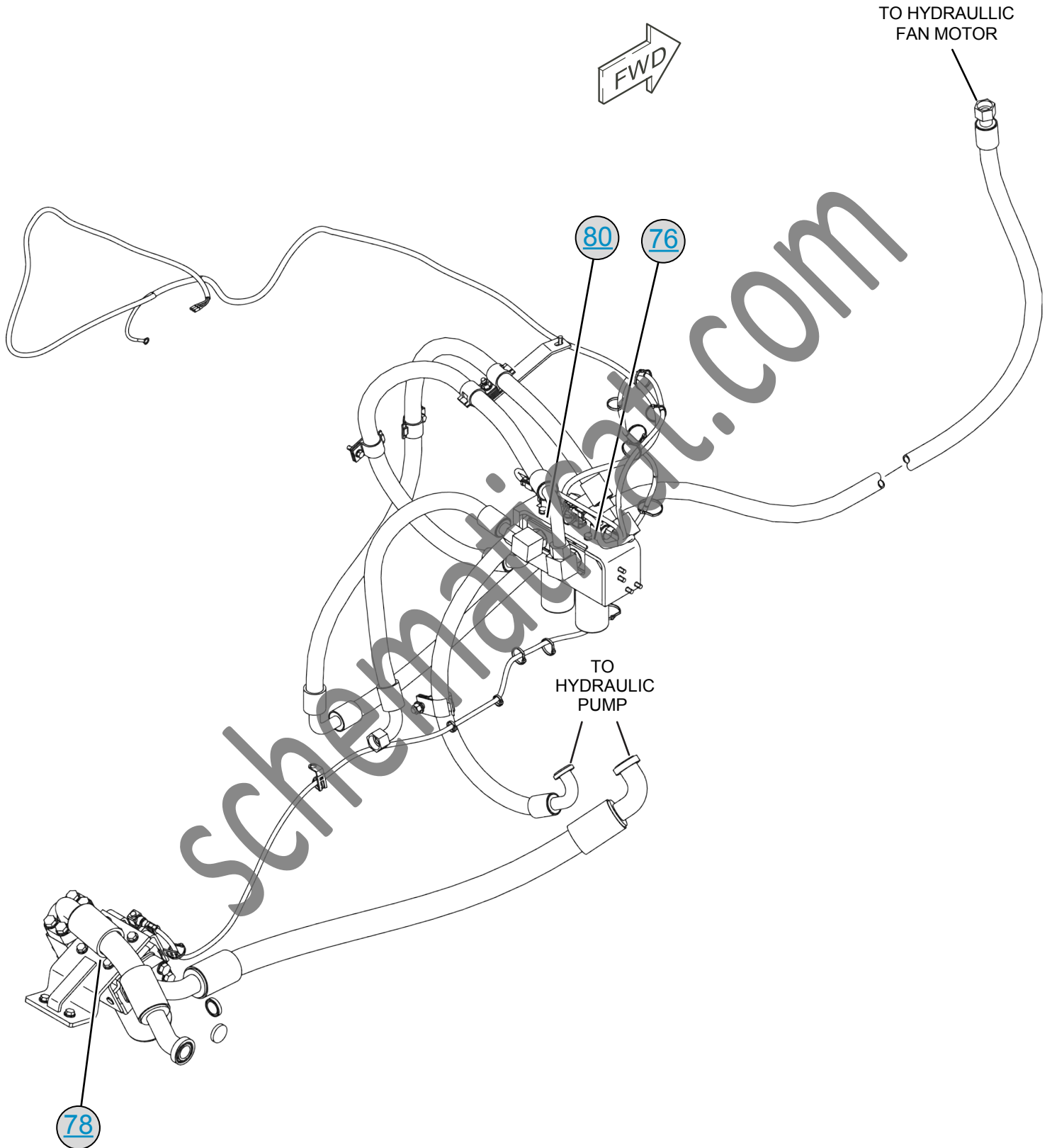

SOLENOID VALVES - TRANSMISSION

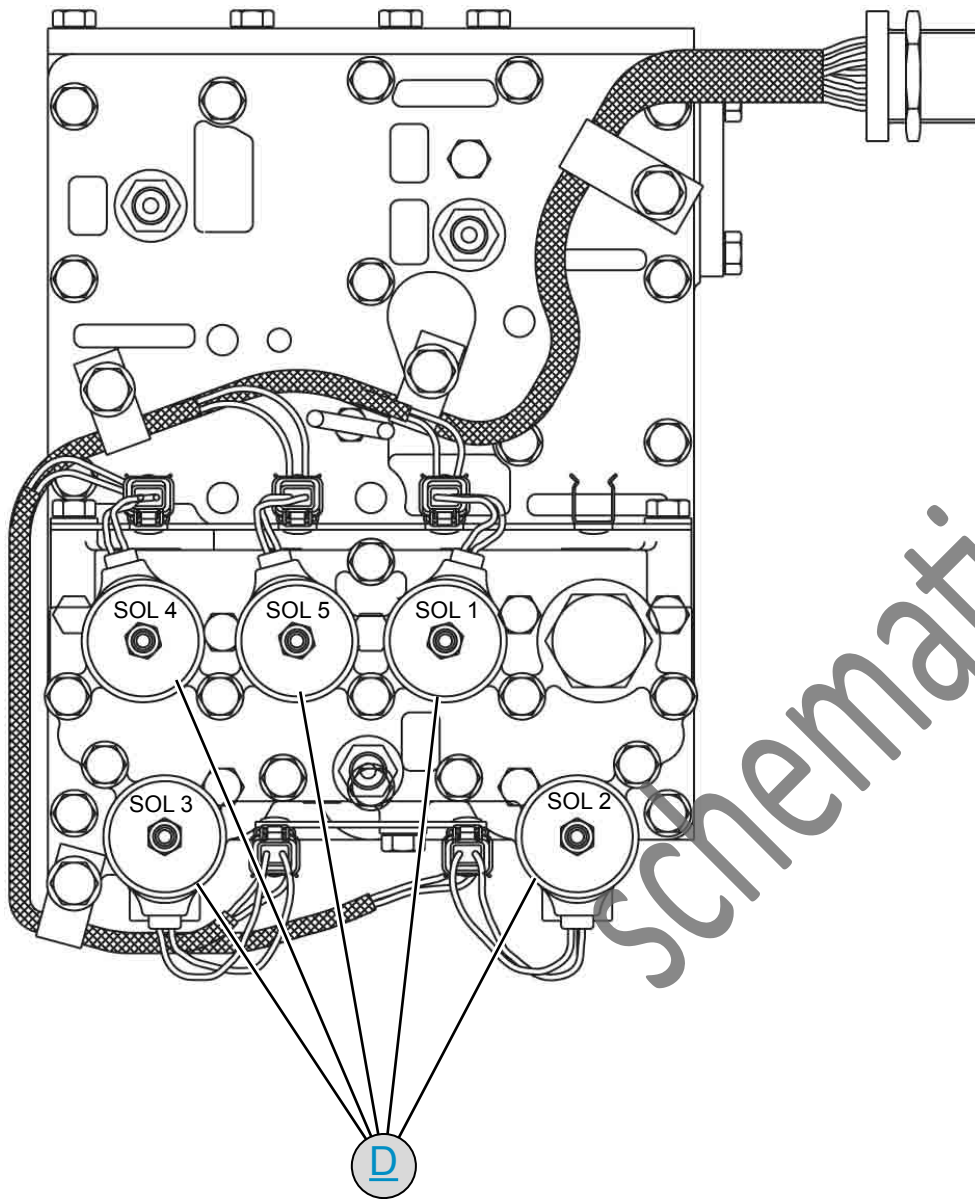

SPEED	SOLENOIDS	CLUTCHES ENGAGED
1F	5 & 2	5 & 2
2F	4 & 2	4 & 2
3F	3 & 2	3 & 2
N	3	3
1R	5 & 1	5 & 1
2R	4 & 1	4 & 1
3R	3 & 1	3 & 1

STEERING AND BRAKING SOLENOIDS

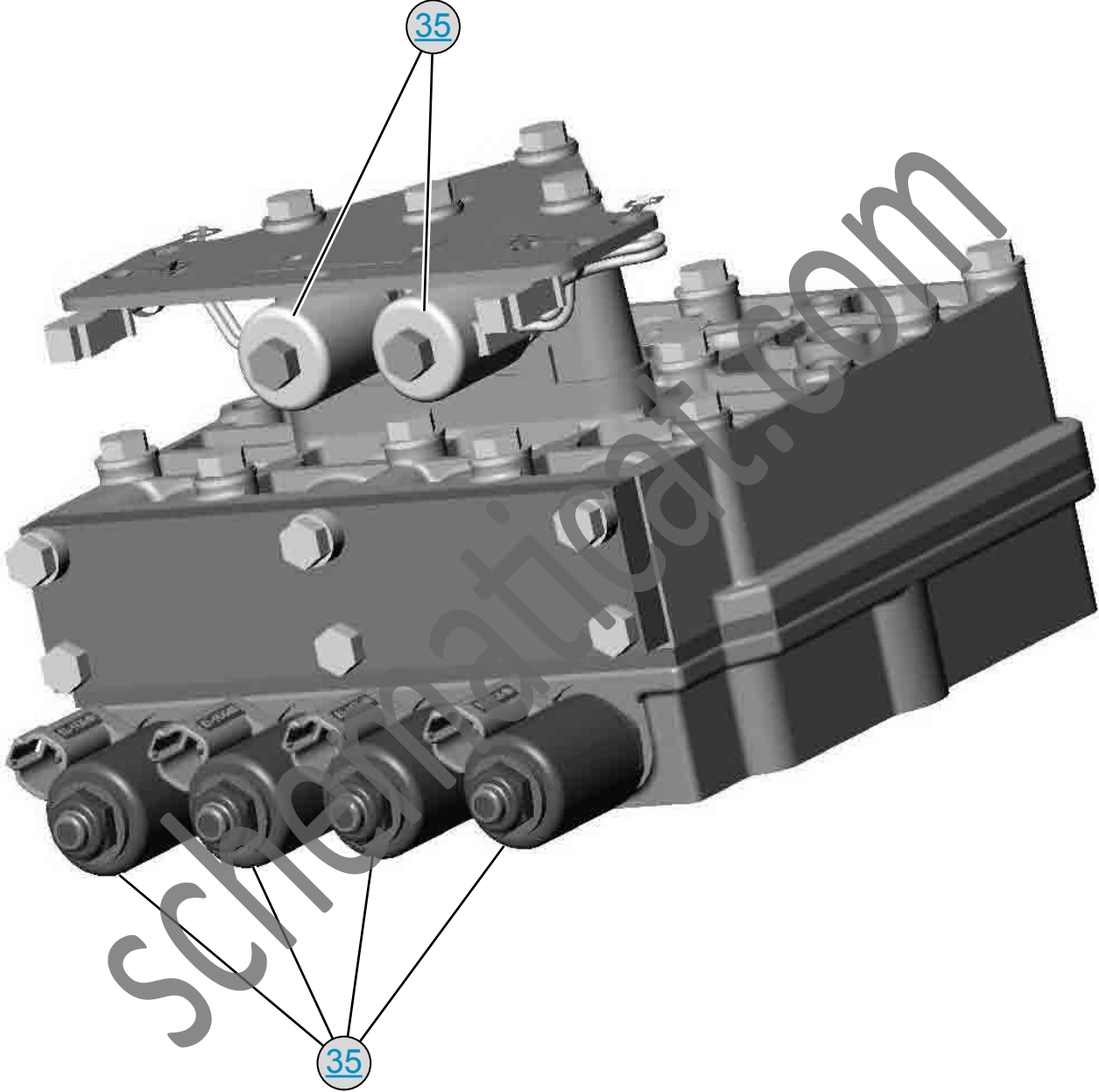

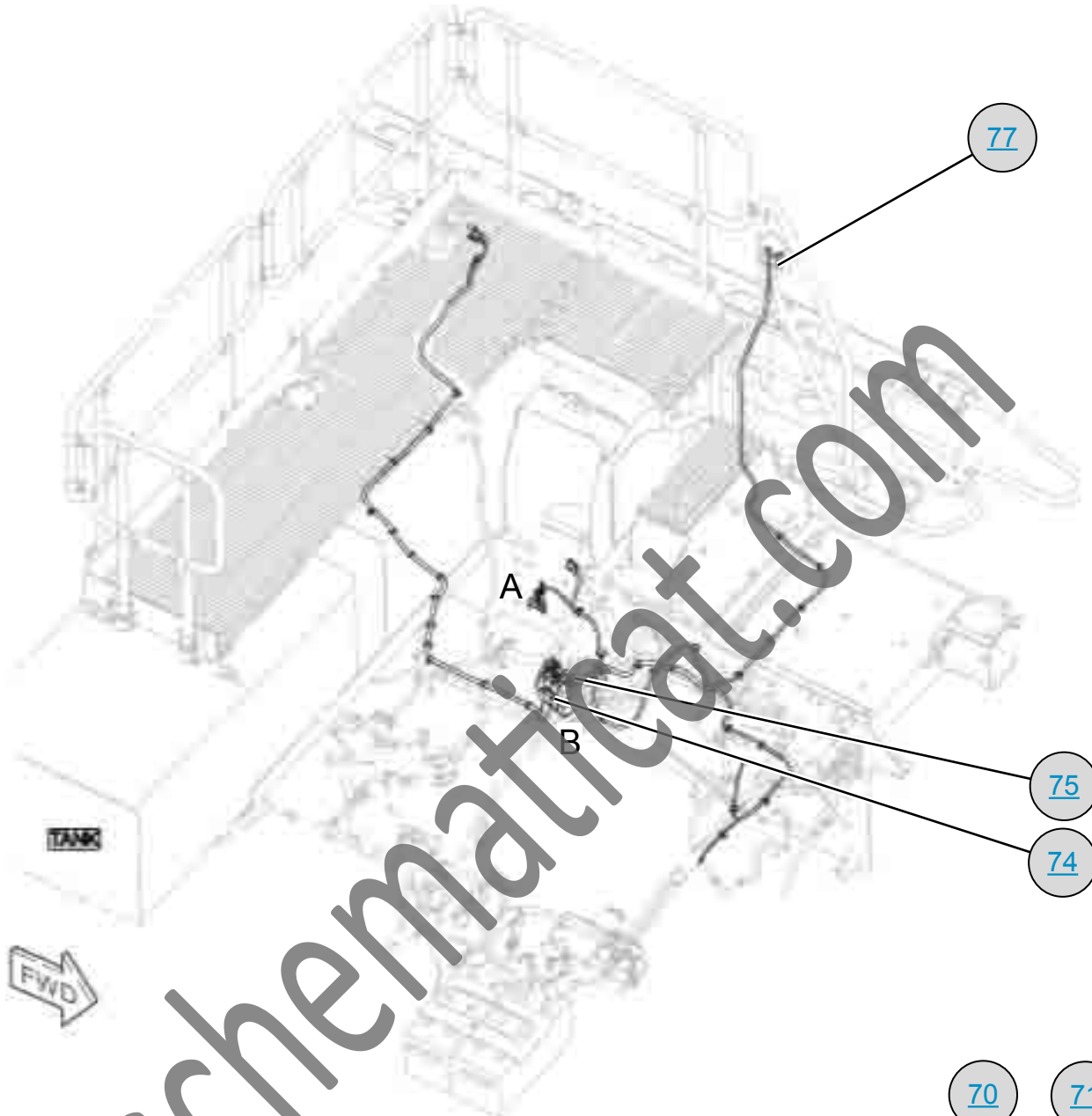

69

View of Area A

72

70

71

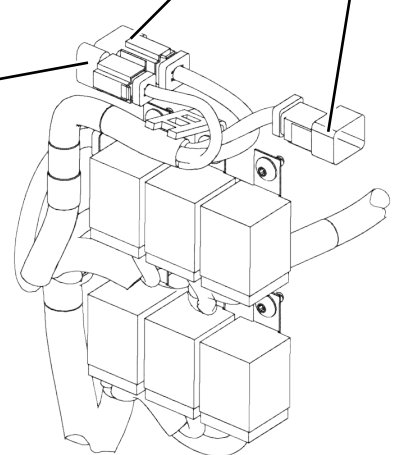

View of Area B