

COMPONENT LOCATIONS

Component Locations			
Description	Part Number	Machine Location	Schematic Location
Standard			
Cooler Gp - Hydraulic	7N-9182	1	C-3
Cylinder Gp - LH Lift	202-4328	2	F-6
Cylinder Gp - RH Lift	202-4328	3	F-5
Filter Gp - Pilot Supply	249-1751	4	E-2
Manifold - Fan Pump	226-6537	5	D-1
Manifold Gp - Pilot, Slctr / Redcr	232-3242	6	E-3
Motor Gp - Fan	229-0892	7	D-3
Pump Gp - Dozer and Lift	228-4838	8	B-3
Pump Gp - Fan and Pilot	204-2576	9	C-2
Solenoid - Artic Option	149-2610	10	D-1
Tank Gp - Hydraulic	295-1072	11	A-3
Valve Gp - Control, Lift / Tilt	244-5440	12	D-6
Valve Gp - Cooler Bypass	4T-0884	13	C-3
Valve Gp - Pilot, Implement Cntrl	285-5625	15	C-4 to E-4
Valve Gp - Quick Dump	153-1814	16	E-5
Valve Gp - Resolver, Shuttle	132-5077	17	E-7
Valve Gp - Vacuum	154-6165	18	A-4
Dual Tilt STD on Carry Dozer			
Cylinder Gp - LH, Dual Tilt	308-2467	20	F-7
Cylinder Gp - RH, Dual Tilt	308-2465	21	F-4
Valve Gp - Control, Dual Tilt	225-2321	22	F-5
Ripper Option			
Cylinder Gp - Ripper Lift, LH	101-8614	30	B-7
Cylinder Gp - Ripper Lift, RH	101-8581	31	B-6
Cylinder Gp - Ripper Pin Puller	6E-3113	32	A-5
Cylinder Gp - Ripper Tilt, LH	130-6381	33	B-7
Cylinder Gp - Ripper Tilt, RH	130-3263	34	B-6
Valve Gp - Ripper Lift / Tip	285-0139	35	C-7
Valve Gp - Solenoid	188-6140	36	A-5
Cruise Control Option			
Valve Gp - Diverter	164-4536	42	B-5
EU Vacuum Breaker Package			
Valve Gp - EU Vacuum Breaker	220-0813	18	A-4
Reference Sensors and Switches			
Switch - Press, Case Drain Bypass	258-0883	60	A-3
Switch As - Fan Filter Bypass	227-6744	61	A-3
Sensor Gp - Pressure	237-0957	62	C-1
Sensor Gp - Pressure	237-0957	63	C-7
Sensor Gp - Pressure	237-0957	64	D-5
Ladder Attachment			
Motor Gp - Gerotor	254-0148	70	F-3
Valve Gp - Control	258-8894	71	F-2

Tap Locations Pressure and Sampling		
Tap Number	Description	Schematic Location
HPD1	Pump Discharge 1	C-7
HPD2	Pump Discharge 2	D-6
HPD3	Pump Discharge 3	B-4
HPS	Pilot Supply	D-3
HPDR	Pilot Lift Raise	D-3
HPDL	Pilot Lift Lower	D-5
HPTL	Pilot Tilt Left	D-3
HPTR	Pilot Tilt Right	D-5
HPRR	Pilot Ripper Raise	C-5
HPRL	Pilot Ripper Lower	C-3
HPSI	Pilot Shank In	C-3
HPSO	Pilot Shank Out	C-5
HFRP	Fan Pump Discharge	D-1
HFM1	Fan Motor Inlet	D-2
HDFP	Demand Fan Discharge	
HPRV	RV Pressure Signal	E-5

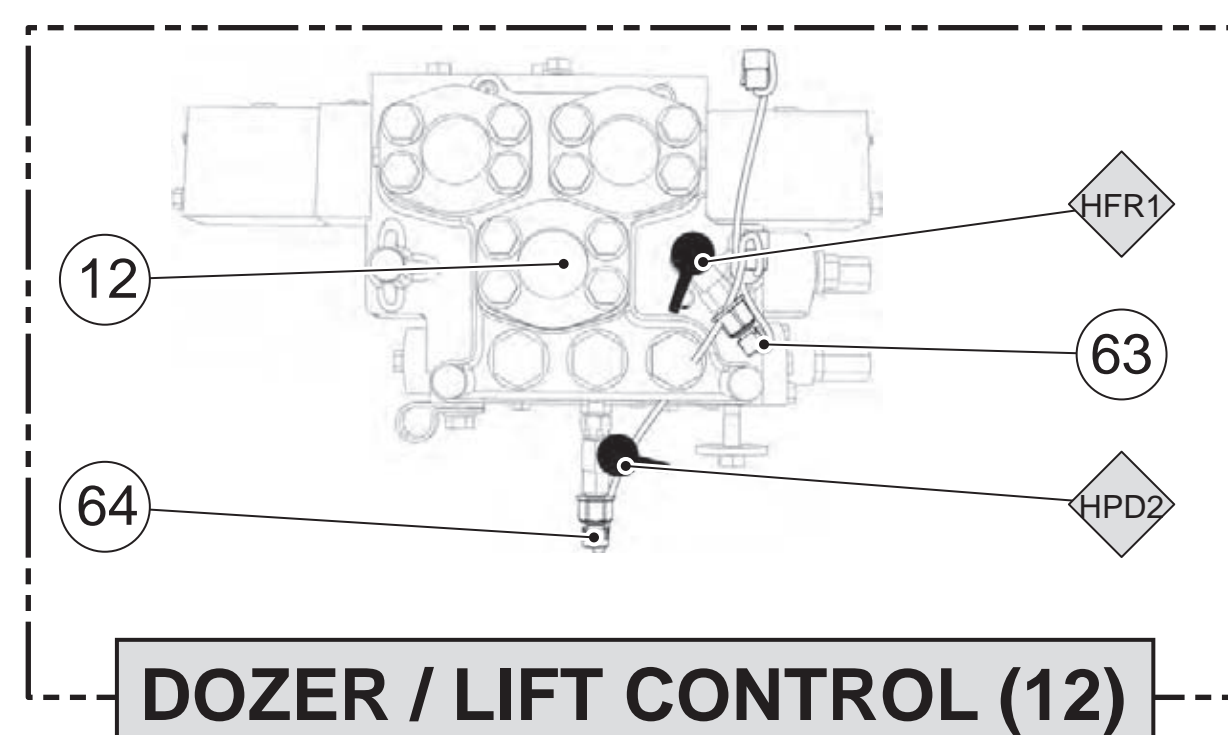

CATERPILLAR® RENR8228-01 November 2007

Schematic

D11T Track-Type Tractor (Carry Dozer) Hydraulic System

TPB1-UP

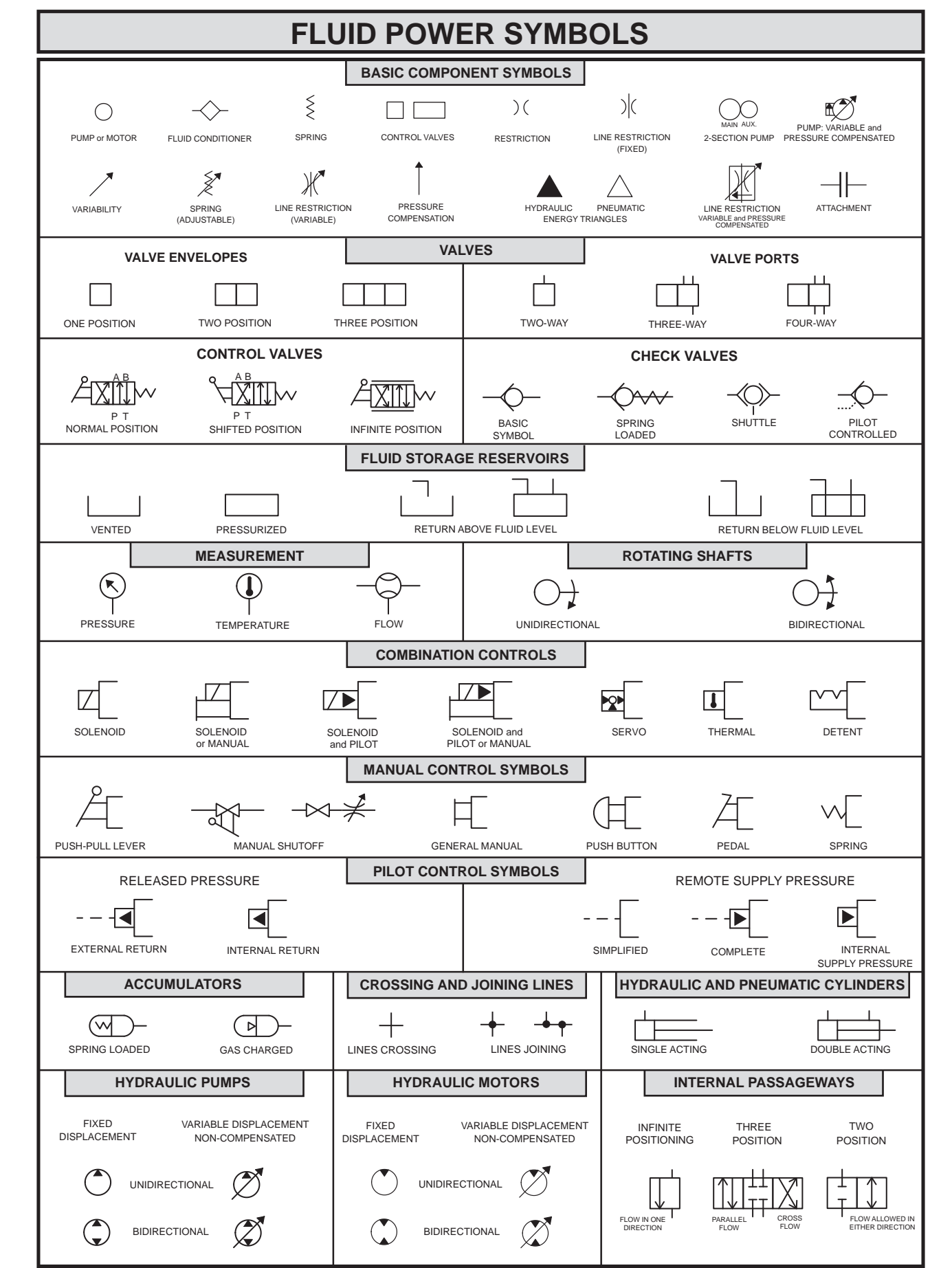
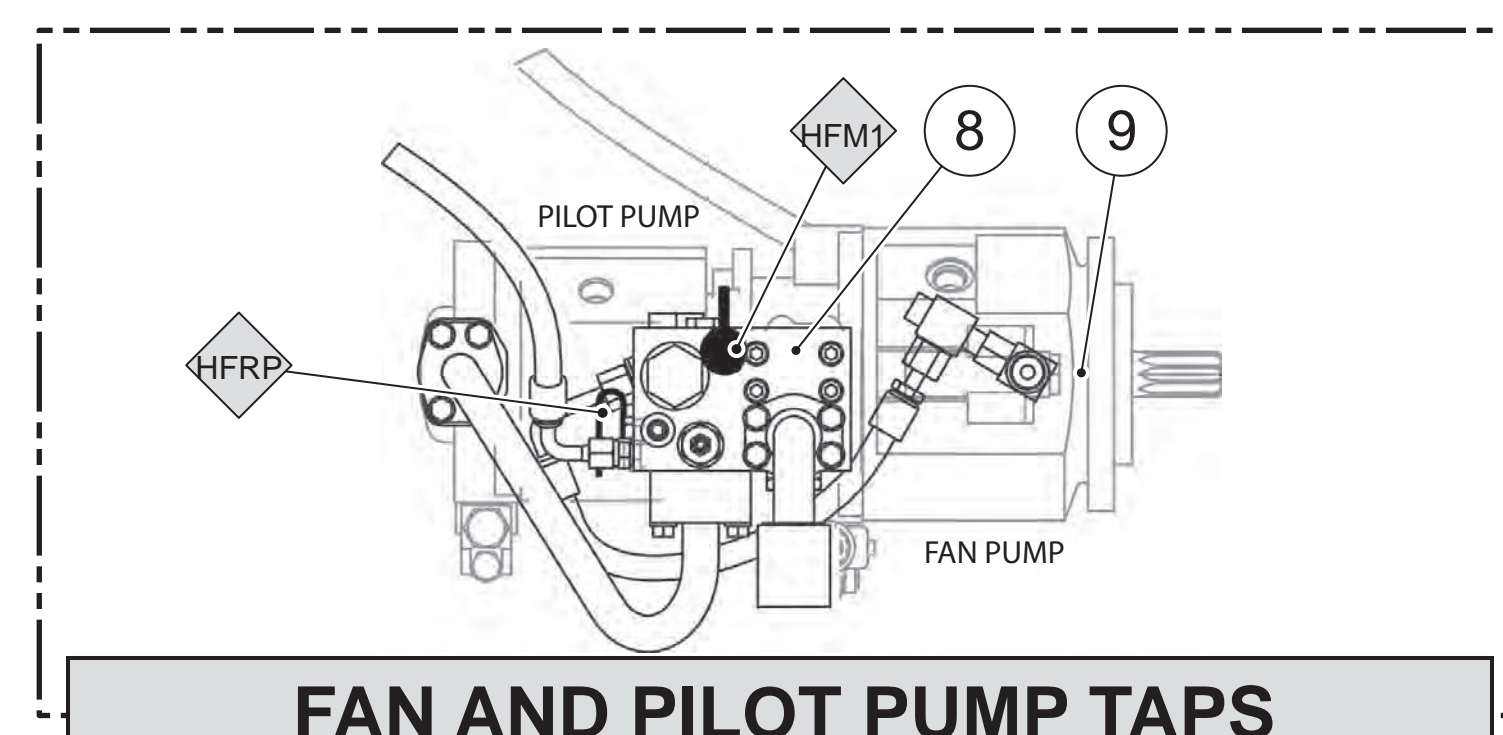
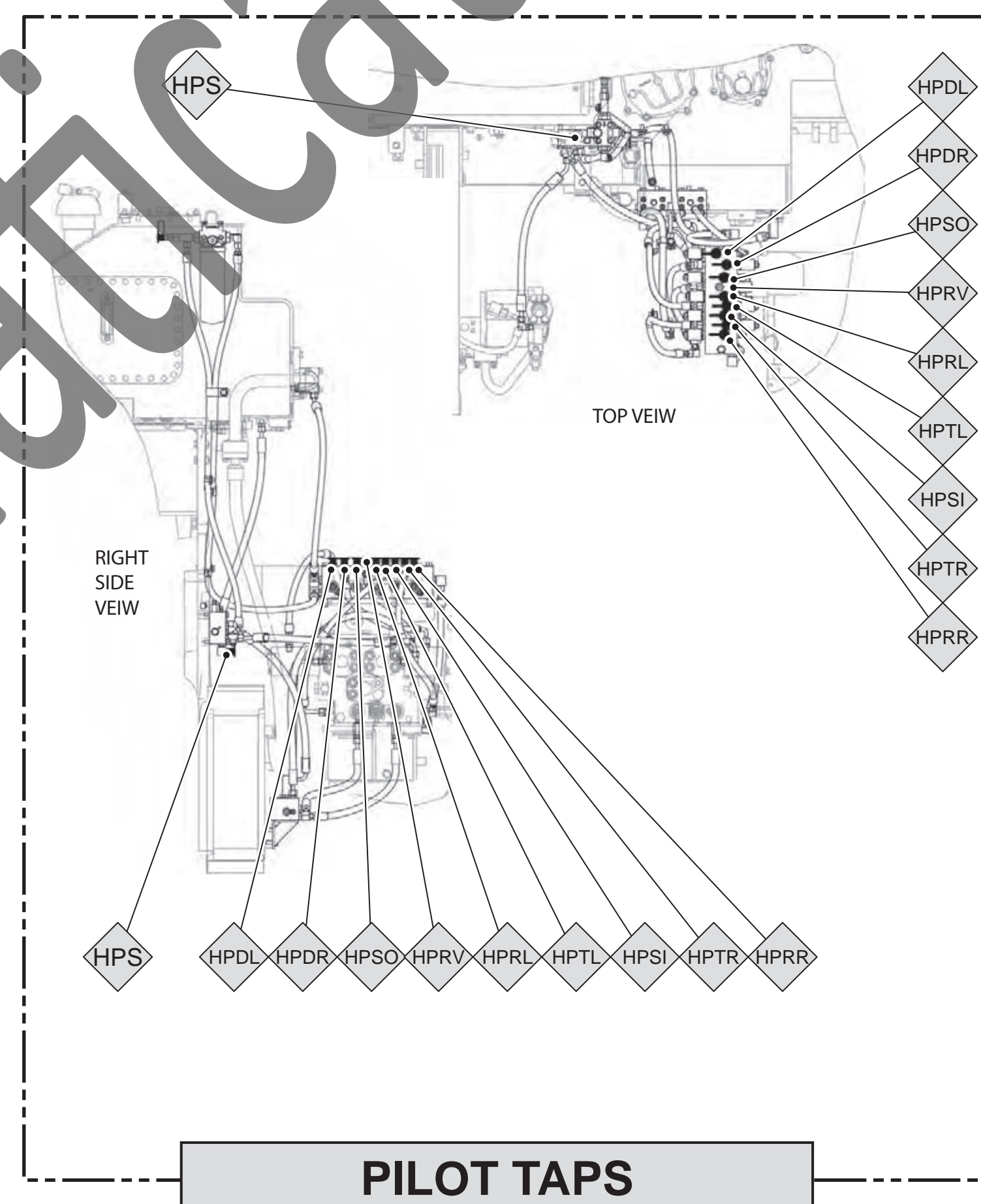

©2007 Caterpillar All Rights Reserved Printed in U.S.A.

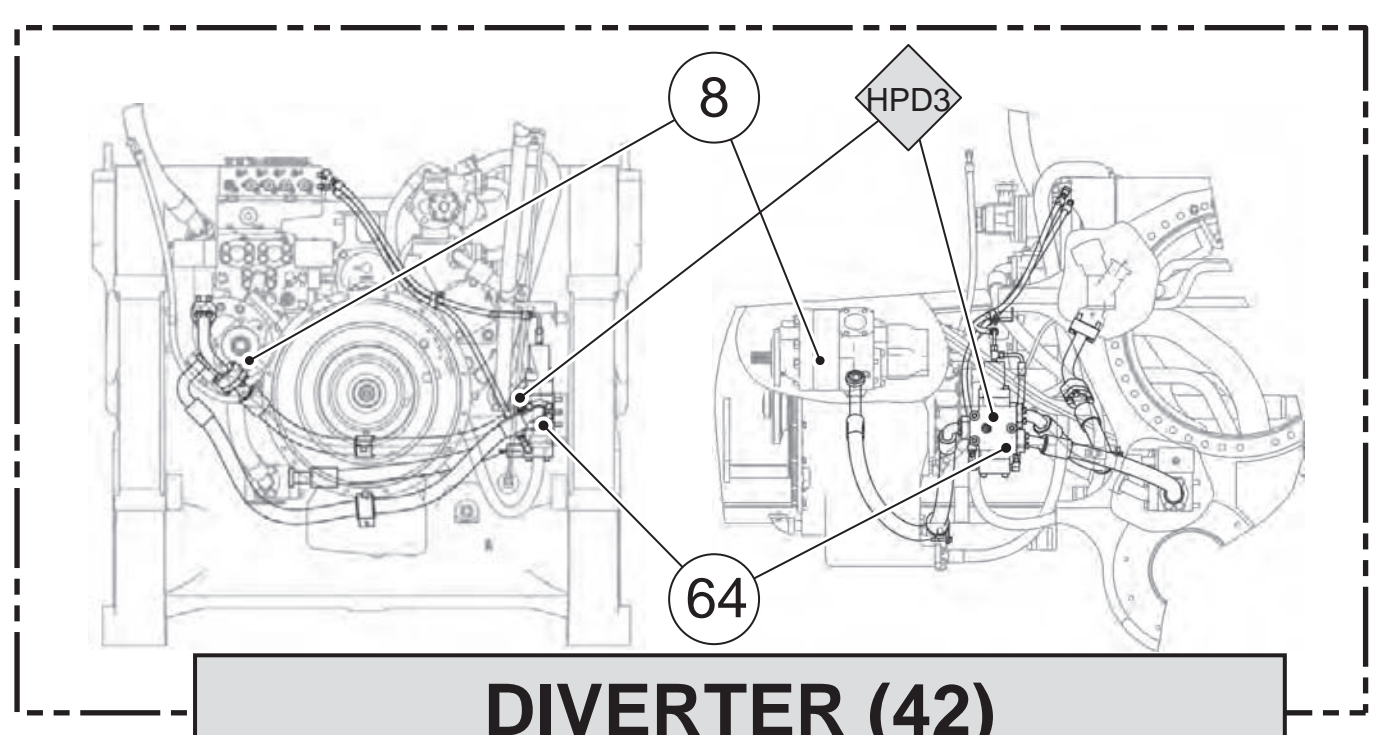
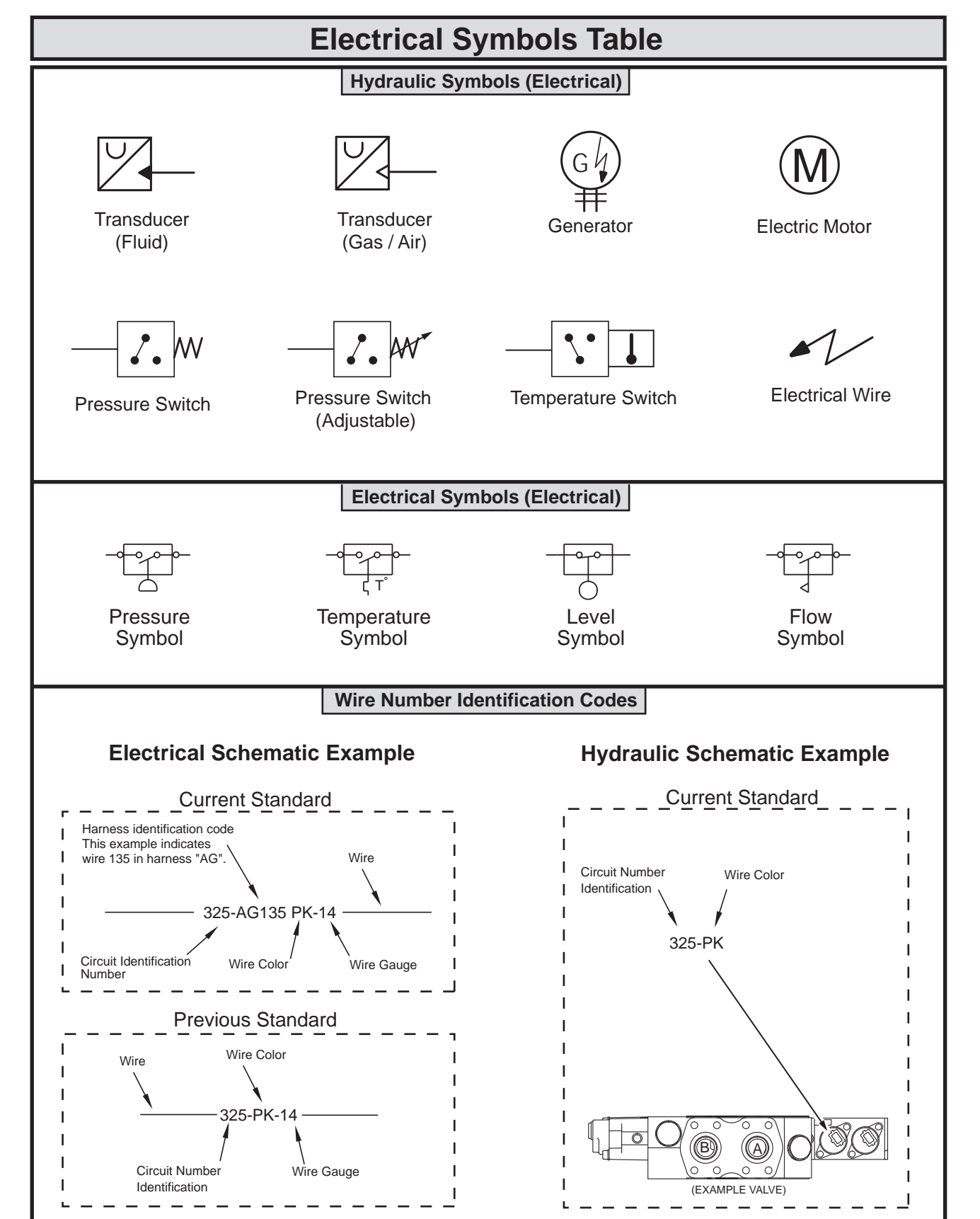

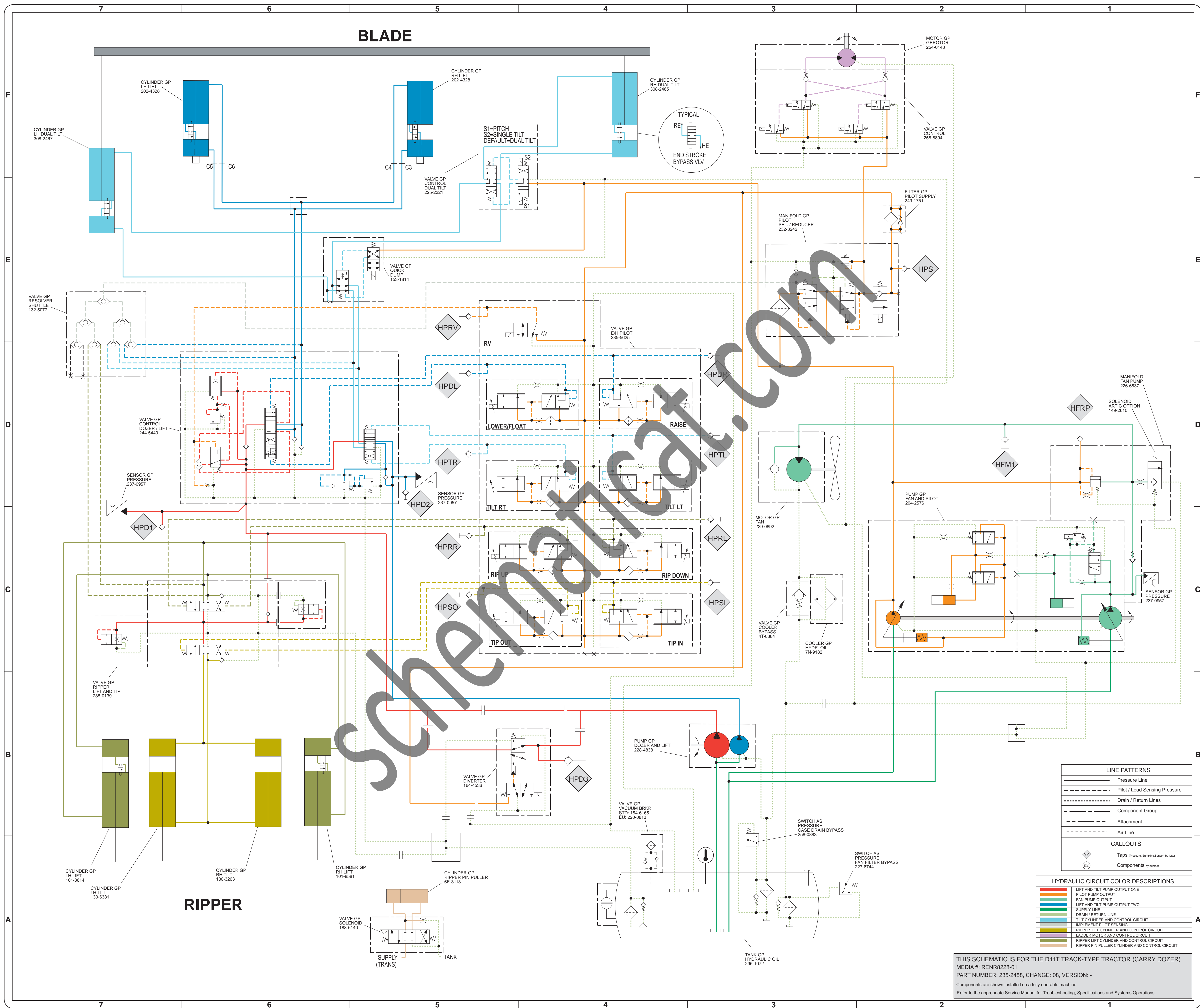

LINE PATTERNS	
	Pressure Line
	Pilot / Load Sensing Pressure
	Drain / Return Lines
	Component Group
	Attachment
	Air Line

CALLOUTS	
	Tap(s) Pressure (Sampling Sensor) by letter
	Components by number

HYDRAULIC CIRCUIT COLOR DESCRIPTIONS	
	LIFT AND TILT PUMP OUTPUT ONE
	PILOT PUMP OUTPUT
	FAN PUMP OUTPUT
	LIFT AND TILT PUMP OUTPUT TWO
	SUPPLY LINE
	DRAIN / RETURN LINE
	TILT CYLINDER AND CONTROL CIRCUIT
	IMPLEMENT PILOT SENSING
	RIPPER TILT CYLINDER AND CONTROL CIRCUIT
	LADDER MOTOR AND CONTROL CIRCUIT
	RIPPER LIFT CYLINDER AND CONTROL CIRCUIT
	RIPPER PIN PULLER CYLINDER AND CONTROL CIRCUIT

THIS SCHEMATIC IS FOR THE D11T TRACK-TYPE TRACTOR (CARRY DOZER)
 MEDIA #: REN8228-01
 PART NUMBER: 235-2458, CHANGE: 08, VERSION: -
 Components are shown installed on a fully operable machine.
 Refer to the appropriate Service Manual for Troubleshooting, Specifications and Systems Operations.