



SEN5318
August 1993

Schematic

D9N Tractor Hydraulic System

1JD (Later)
6X11-UP

Schematic.com



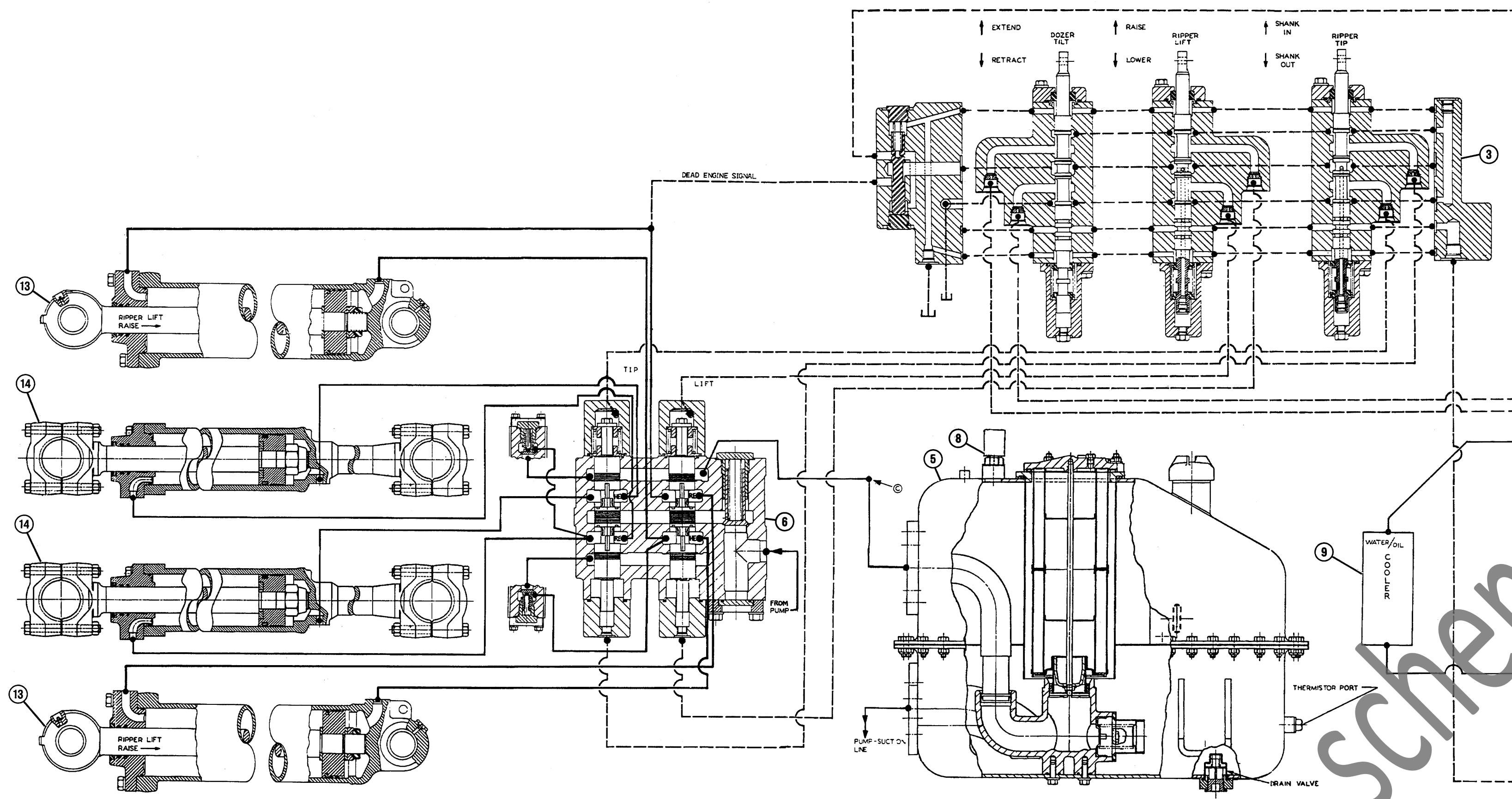
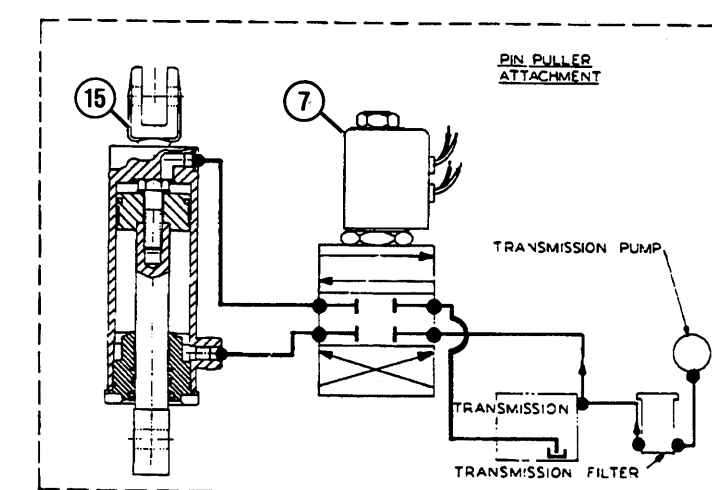
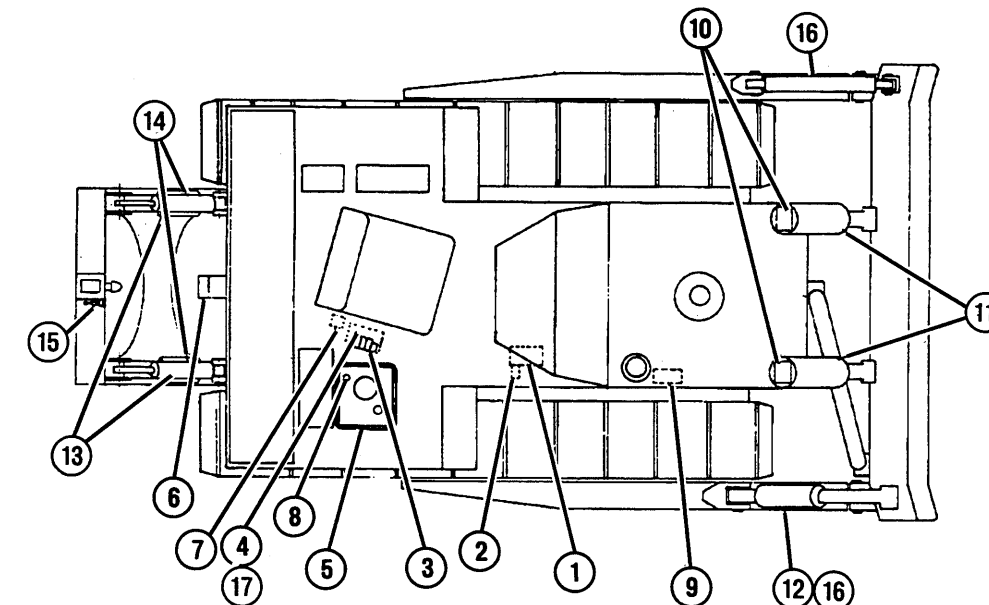

C48456X1

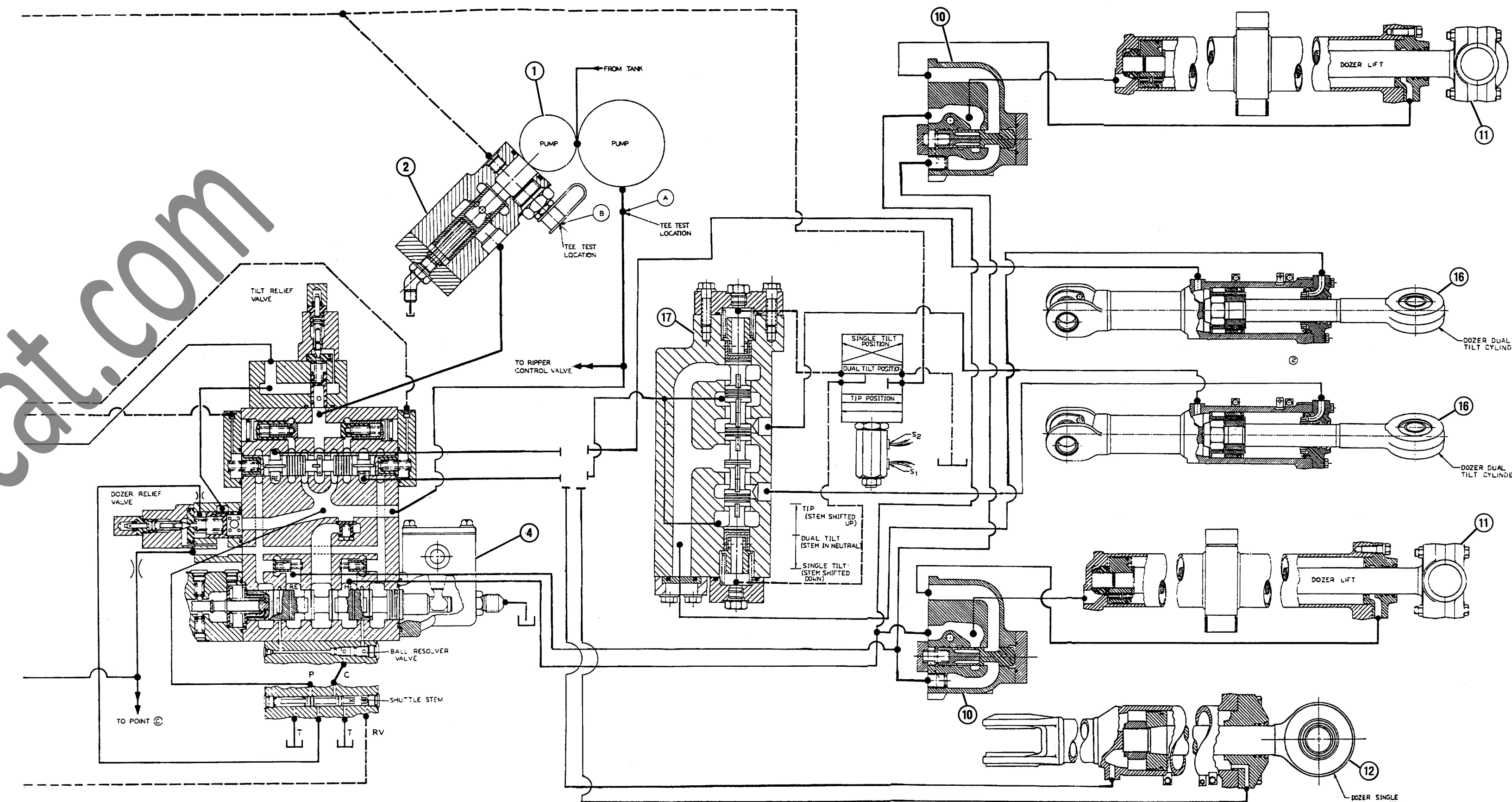

C48457X1

Item	Description
1.	Hydraulic Pump
2.	Pressure Control (Restrictor) Valve
3.	Pilot Valve Group
4.	Bulldozer Control Valve
5.	Tank and Filter Group
6.	Ripper Lift and Tip Control Valve
7.	Pin Puller Control Valve
8.	Vacuum Breaker Relief Valve
9.	Oil Cooler (Optional)
10.	Quick Drop Valve
11.	Bulldozer Lift Cylinders
12.	Bulldozer Tilt Cylinder
13.	Ripper Lift Cylinders
14.	Ripper Tip Cylinders
15.	Pin Puller Cylinder Group
16.	Bulldozer Dual Tilt Cylinders
17.	Dual Tilt Valve Group