

Component Location			
Component	Schematic Location	Machine Location	Component
Alarm - Action	C-12	1	Motor - Starter and Prehabe
Alarm - Backup	F-12	2	Radio
Alternator	F-2	3	Receptacle - Auxiliary Start
Assembly - Diode	D-2	4	Relay
Assembly - Diode	H-2	5	Relay - Main
Assembly - Diode	I-10-2	6	Relay - Start
Batteries	A-4	7	Resistor
Batteries	I-2	8	Resistor
Breaker - A/C Condenser (15A)	B-9	A	Resistor
Breaker - Alternator (80A)	G-4	9	Resistor
Breaker - Blower (15A)	B-9	A	Seal Components
Breaker - Control (15A)	B-9	A	Sensor - Coolant Temperature
Breaker - Headlamp (15A)	B-9	A	Sensor - Engine Oil Pressure
Breaker - Key (10A)	B-9	A	Sensor - Engine Speed
Breaker - Main (80A)	F-4	9	Sensor - Hydraulic Oil Temperature
Breaker - Power Outlet (15A)	B-9	A	Sensor - Powertrain Oil Temperature
Clutch - Air Conditioner	D-2	4	Sensor - Ultrasonic Fuel Level
Converter - Voltage	D-12	10	Socket - Power Outlet
Diode	A-12	11	Solenoid - Dual Till
Fuses - Seat Heat/Air	D-10	8	Solenoid - Prehabe Trimer
Ground - Beam	A-5	12	Solenoid - Quick Drop Valve
Ground - Beam	I-6	13	Solenoid - Ripper Pin Puller
Ground - Cab Roof	C-11	D	Switch - A/C Refrigerant Pressure
Ground - Chassis	A-12	14	Switch - Accessory
Ground - Engine	A-4	15	Switch - Backup Alarm
Ground - Engine	F-2	3	Switch - Blower
Ground - Engine	A-3	16	Switch - Coolant Temperature
Ground - Fender	A-5	12	Switch - Disconnect
Ground - Fender	A-12	14	Switch - Engine Coolant Flow
Ground - Fender	E-12	17	Switch - Filter Bypass Temperature
Ground - Frame	I-5	13	Switch - Forward Horn
Ground - Frame	A-4	15	Switch - Front Wiper
Ground - Frame	A-6	12	Switch - Monitor Dimmer
Ground - Frame	I-3	16	Switch - Head Lamp
Ground - Fuel tank	A-12	14	Switch - Hydraulic Oil Filter
Ground - Module	G-7	A	Switch - Hydraulic Oil Filter Bypass
Ground - Module	I-6	13	Switch - Key
Hom - Forward (High/Low Tone)	H-1	19	Switch - Left Wiper
Joystick - Winch	C-10	B	Switch - Neutral / Start
Lamp - Action	B-7	A	Switch - Oil Pressure
Lamp - Action	C-12	1	Switch - Pitch Control
Motor - Scraper	B-7	A	Switch - Powertrain Filter
Monitor - Operator (CMS)	H-9	A	Switch - Quick Drop
Motor - Blower	I-10-12	20	Switch - Rear Wiper
Motor - Condenser	A-11B-11	20	Switch - Right Wiper
Motor - Washer Pumps	I-12	21	Switch - Ripper Pin Puller
Motor - Front Wiper	C-9	22	Switch - Side Flood Lamp
Motor - Left Wiper	H-9	23	Switch - Single/Dual Till
Motor - Rear Wiper	E-11	24	Switch - Start Aid
Motor - Right Wiper	B-9	25	Switch - Thermostat
Motor - Starter (Attachment)	A-4	15	

Machine locations are repeated for components located close together.
A = Components located in dash.
B = Components located in right console area.
C = Components located in left console area.
D = Components located in headliner.
E = Components located under seat.

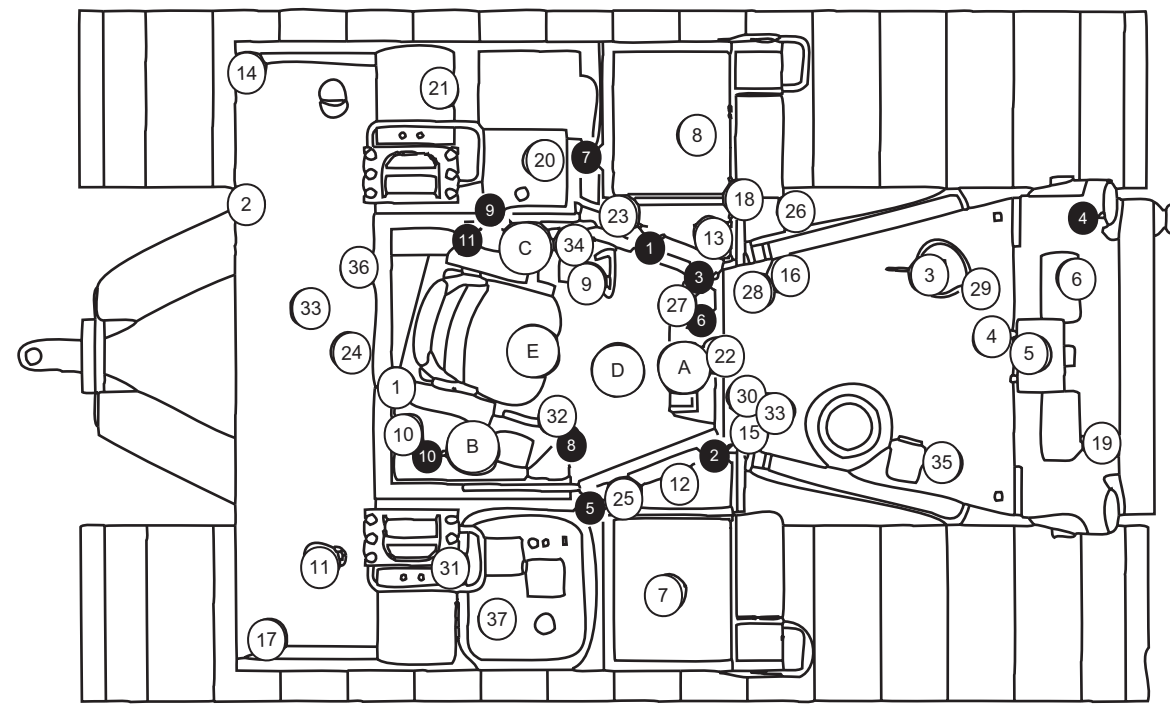

Machine Harness Connector and Component Locations

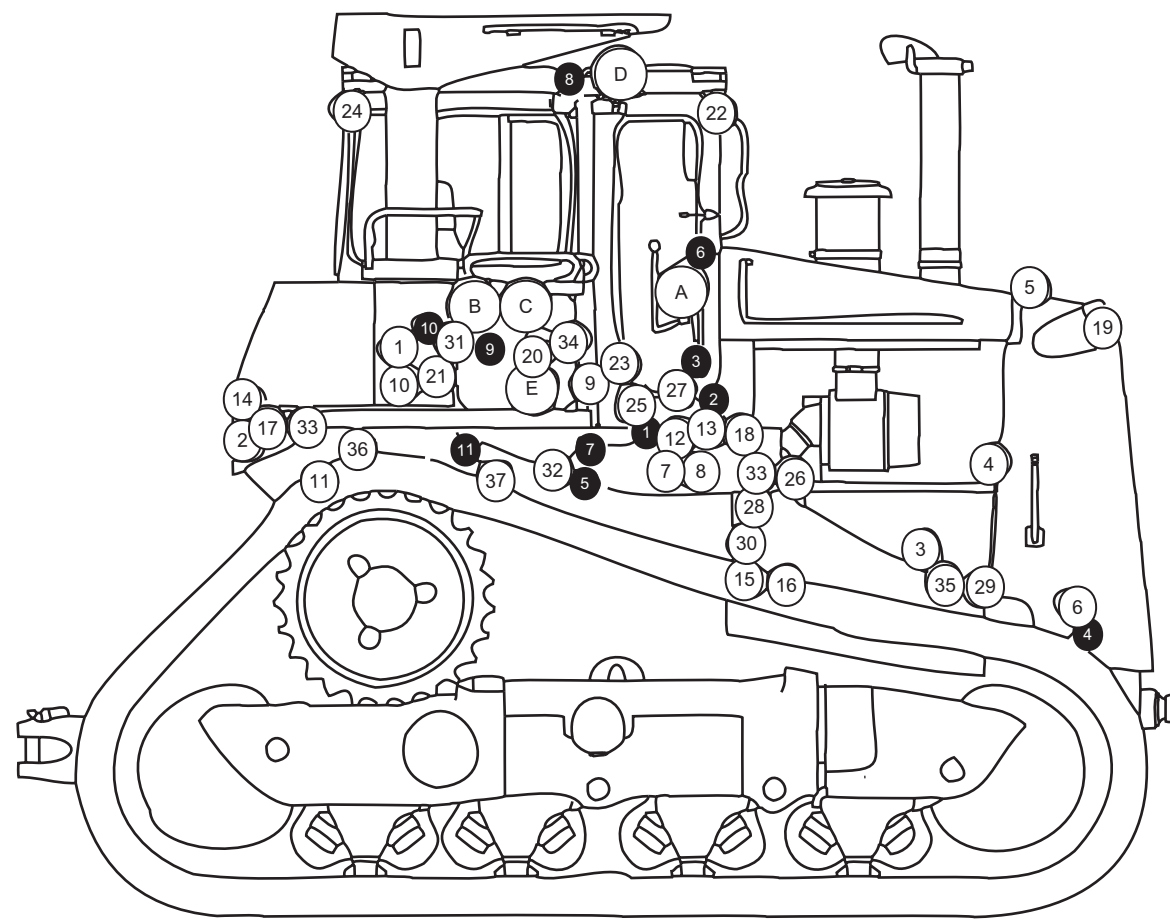

SEN95392-02
August 1997

Schematic

D9R Tractor Electrical System

Machine: 7TL1-851
Machine: 8BL1-1052
Engine: 48W1-Up

Wire Description					
Wire Number	Wire Color	Description	Wire Number	Wire Color	Description
101	RD	Battery (+24V)	500	BR	Forward Wiper Intermittent
102	RD	Front Flood Power	501	GN	Forward Wiper Motor Low
105	RD	Keyswitch Power	502	DR	Forward Wiper Motor High
108	BU	Wiper/Ether Aid Power	503	BR	Rear Wiper Intermittent
109	RD	Alternator Output (+24V)	504	YL	Rear Wiper Motor Low
112	PU	Main Power (switched)	505	BU	Rear Wiper Motor High
113	OR	Monitor Power (+24V)	506	PU	Front Washer
114	RD	Horn Fuse	507	WH	Rear Washer
116	BR	Rear Flood Fuse	508	PU	Left Speaker
121	RD	Backup Alarm Fuse	509	WH	Left Speaker
124	GN	Blower / A/C Power	511	BR	Right Speaker
125	OR	Side Flood Fuse	512	GN	Right Speaker
130	GN	Seat Air Suspension	513	OR	A/C Clutch to Pressure SW
131	BR	Seat Heater	515	GY	Blower High
150	RD	Engine ECM Power (340BE ONLY)	516	GN	Blower Medium
158	BR	Remote Condenser Blower Fuse	517	BU	Blower Low
174	PK	Accessory Fuse	521	YL	Accessory SW to Pressure SW
177	RD	Main Power - Unswitched	522	WH	A/C Clutch to Thermostat SW
186	RD	Power Outlet Fuse	523	BR	Left Wiper Intermittent
Ground Circuits					
200	BK	Machine Ground	525	GY	Left Wiper Motor High
201	BK	Monitor Ground	526	YL	Right Wiper Intermittent
203	BK	Disconnect SW to Diagnostic Connector	527	GN	Right Wiper Motor Low
207	BK	Starter Ground to Diagnostic Connector	528	PK	Right Wiper Motor High
270	BK	Monitor Code 0	529	WH	Left Washer
271	BK	Monitor Code 1	530	OR	Right Washer
272	BK	Monitor Code 2	553	YL	Dual TR SW to Dual TR Valve
273	BK	Monitor Code 3	554	PK	Dual TR SW to Dual TR Valve
274	BK	Monitor Code 4	592	BU	+12V Power
290	BK	Service (Monitor)	AS13	PK	+12V Radio Memory
291	BK	Clear (Monitor)	Lighting Circuits		
Basic Machine Circuits					
301	BU	Starter 1 Motor Terminal	608	GN	Rear Floods
302	OR	Starter 1 Motor Diagnostic	609	YL	Side Floods
304	WH	Starter 1 Solenoid	610	OR	Front Floods
306	GN	Neutral Start SW to Start Relay	630	GY	Ripper Flood
307	OR	Keyswitch Start	631	BU	Accessories Power
308	YL	Keyswitch On	643	GN	Dimmer SW - Up
310	PU	Ether Aid SW to Ether Solenoid	644	OR	Dimmer SW - Down
311	WH	Ether Aid Temp SW to Ether Solenoid	Control Circuits		
312	PK	Starter 2 Motor Terminal	779	WH	Ripper Pin Puller
313	GY	Starter 2 Motor Diagnostic	780	PU	Ripper Pin Puller
314	PU	Starter 2 Solenoid	A700	OR	Engine Sensor Power (340BE ONLY)
321	BR	Backup Alarm to Backup Alarm SW	E783	BU	ATA Data Link (340BE ONLY)
322	GY	Horn	E794	YL	ATA Data Link (340BE ONLY)
337	WH	Keyswitch to Neutral Start SW	F702	GN	Decelerator Pedal (340BE ONLY)
340	GN	Mastering Circuits	F715	PU	Throttle SW (340BE ONLY)
403	GN	Alternator Rt. Terminal	F716	WH	Throttle SW (340BE ONLY)
405	GY	Engine Oil Pressure	F717	YL	Throttle SW (340BE ONLY)
410	WH	Action Alarm	F718	BU	Throttle SW (340BE ONLY)
411	PK	Action Lamp	F721	GY	Integrated Ether SW (340BE ONLY)
412	BU	Coolant Flow SW	G703	GN	Quick Drop SW to Quick Drop Valve
426	BR	PTO Flow SW	892	BR	Cat Data Link
441	OR	Coolant Temperature Sensor	893	GN	Cat Data Link
442	GY	Hydraulic Temperature	988	BR	Digital Return (340BE ONLY)
443	YL	PTO Temperature			
447	PK	Fuel Level			
450	YL	Engine Speed			
499	GY	Hydraulic Filter SW			
A401	RD	System Voltage (Monitor)			
A447	PK	Prehabe Oil Pressure			

©1997 Caterpillar
All Rights Reserved

Printed in U.S.A.

Connector Location			
Connector	Machine Location	Harness And/Or Components	Schematic Location
40 Contacts	1	B - 120-8463 D - 120-7433	H-5
24 Contacts	2	P - 9U-9046 N - 9U-9042	H-9
29 Contacts	3	C - 120-8189 D - 120-7433	C-5
12 Contacts	4	D - 120-7433 E - 9U-9040	I-7
9 Contacts	5	C - 120-8189 N - 9U-9042	H-6
8 Contacts	6	B - 120-8463 L - 9U-9044	H-9
8 Contacts	7	C - 120-8189 D - 120-7433	A-10
8 Contacts	8	C - 120-8189 G - 9U-9045	B-10
6 Contacts	9	P - 9U-9046 Q - 9U-9049	C-10
6 Contacts	10	B - 120-8463 D - 120-7433	H-3
6 Contacts	11	C - 120-8189 G - 9U-9045	C-5
6 Contacts	12	B - 120-8463 Z - 120-1261	I-2
6 Contacts	13	E - 9U-9040 K - 120-8993	E-2
6 Contacts	14	N - 9U-9042	D-11

B - 120-8463 Differential Steering only
B - 120-8036 Clutch / Brake only
H - 120-4396 Differential Steering only
H - 120-2006 Clutch / Brake only
I - 9U-9044 Differential Steering only
U - 101-8259 Clutch / Brake only
Z - Connector is located on the component.
Machine locations are repeated for connectors located close together.

Related Electrical Service Manuals	
Title	Form Number
Alternator	SEN97508
Computerized Monitoring System (CMS)	SEN95247
Starting And Charging Systems	SEN92947
Starting Motor: 50-MT Series	SEN93860

Off Machine Switch Specification			
Part No.	Function	Actuate	Deactuate
3E-6425	Coolant Temperature	38 ± 3°C (100.4 ± 5.4°F)	27°C MIN (80.6°F MIN)
3E-6428	Coolant Flow (CMS)	362 ± 29mm (45.6mm ID point) (1.3 ± .1oz, 1.8in ID point)	303mm (1.1in) (1.1oz, 1.4in ID point)
3E-8350	Filter Bypass Temperature (CMS)	52 ± 3°C (125.6 ± 5.4°F)	120°C MIN (248°F MIN)
9X-7781	Hydraulic Oil Filter/ Power Train Filter Pressure (CMS)	210 ± 70kPa (30 ± 10psi)	30 ± 7kPa (4.3 ± 1.0psi)
105-9152	Oil Pressure (CMS)	30 ± 7kPa (4.3 ± 1.0psi)	30 ± 7kPa (4.3 ± 1.0psi)
114-5333	Refrigerant Pressure (AC)	275 to 1750 kPa* (40 to 255 psi)	25 ± 3°C (77 ± 5.4°F)
124-8274	Hydraulic Oil Filter Bypass (CMS)	25 ± 3°C (77 ± 5.4°F)	25 ± 3°C (77 ± 5.4°F)

* A hysteresis band exists: with increasing pressure the closed condition cycle is maintained up to 2800 kPa (405 psi), with decreasing pressure the closed condition can be maintained down to 170 kPa (25psi).
* Contact position at the contacts of the harness connector.

Resistor, Sender and Solenoid Specifications		
Part No.	Component Description	Resistance (Ohms) ¹
9G-1950	Blower - Blower Motor Speed	Overall 2.0 ± .1; Tap 1.0 ± .05
3E-7842	Blower - Starter/Diagnostic System Volt	150 ± 7.5
102-0347	Solenoid - Air Conditioner Clutch	14.4 ± 0.6
3E-9205	Solenoid - Start Aid	24.9
109-3032	Solenoid - Quick Drop Valve	34.3 ± 1.7
3E-8575	Solenoid - Ripper Pin Puller	24.9
3E-6333	Solenoid - Start Aid / Fuel Level Sensor	6.0

¹ At room temperature unless otherwise noted.

MODULE IDENTIFIER (MID)	
MID No.	Module
26	Computerized Monitoring System (CMS)

COMPONENT IDENTIFIER (CID) LIST	
CID No.	Component
086	Fuel Level Sensor
100	Engine Oil Pressure Sensor
110	Engine Coolant Temperature Sensor
168	Electrical System Voltage
177	Power Train Oil Temperature Sensor
248	CAT Data Link
270	Harness Code
271	Action Alarm
324	Action Lamp
660	Hydraulic Oil Temperature Sensor
661	Brake Air Pressure Sensor
627	Parking Brake Switch

Failure Mode Identifiers (FMI)	
FMI No.	Failure Description
0	Data valid but above normal operational range
1	Data valid but below normal operational range
2	Data erratic, intermittent, or incorrect
3	Voltage above normal or excited high
4	Voltage below normal or shorted low
5	Current below normal or open circuit
6	Current above normal or grounded circuit
7	Mechanical system not responding properly
8	Abnormal frequency, pulse width, or period
9	Abnormal update
10	Abnormal rate of change
11	Failure mode not identifiable
12	Bad device or component
13	Out of calibration

Electrical Schematic Symbols And Definitions

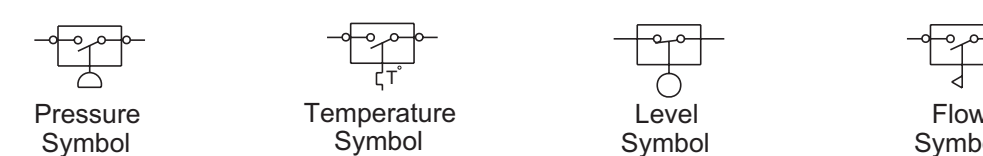

Normally open switch that will close with an increase of a specific condition (temp-press-etc.).

Normally open switch that is closed due to an applied condition, and will open again with a specific decrease in that condition.

Normally closed switch that will open with an increase of a specific condition.

Normally closed switch that is open due to an applied condition, and will close again with a specific decrease in that condition.

The circle indicates that the component has screw terminals and a wire can be disconnected from it.

No circle indicates that the wire cannot be disconnected from the component.

This indicates that the component has a wire connected to it that is connected to ground.

This indicates that the component does not have a wire connected to ground. It is grounded by being fastened to the machine.

Harness And Wire Electrical Schematic Symbols

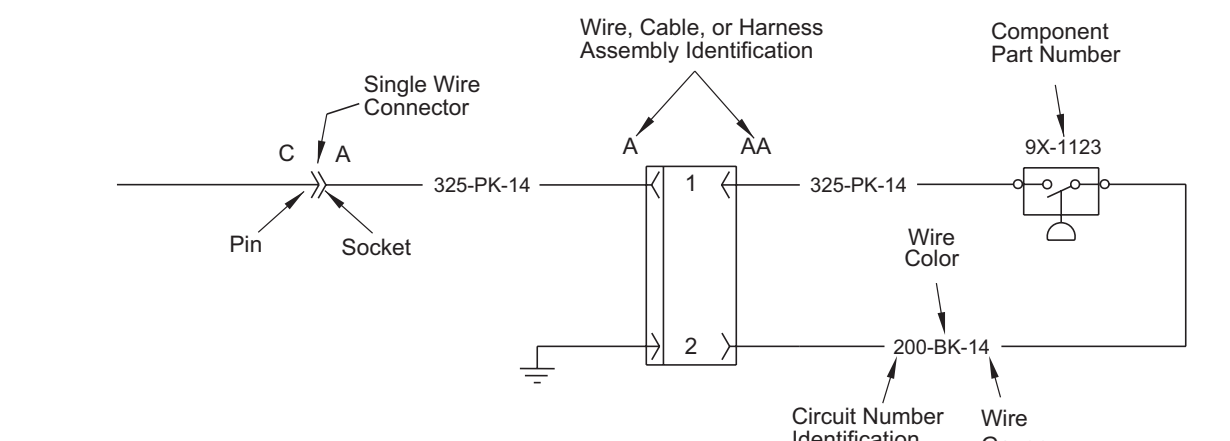
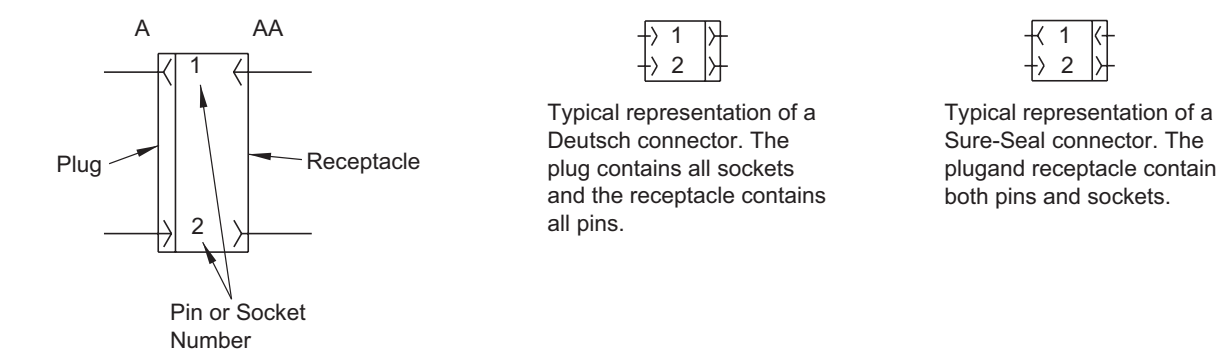

Electrical Schematic Symbols And Definitions

FUSE - A component in an electrical circuit that will open the circuit if too much current flows through it.

REED SWITCH - A switch whose contacts are controlled by a magnet. A magnet closes the contacts of a normally open reed switch; it opens the contacts of a normally closed reed switch.

SENDER - A component that is used with a temperature or pressure gauge. The sender measures the temperature or pressure. Its resistance changes to give an indication to the gauge of the temperature or pressure.

RELAY (Magnetic Switch) - A relay is an electrical component that is activated by electricity. It has a coil that makes an electromagnet when current flows through it. The electromagnet can open or close the switch part of the relay.

CIRCUIT BREAKER (CB) - A component in an electrical circuit that will open the circuit if too much current flows through it. This does not destroy the circuit breaker and it can be reset to become part of the circuit again.

SOLENOID - A solenoid is an electrical component that is activated by electricity. It has a coil that makes an electromagnet when current flows through it. The electromagnet can open or close a valve or move a piece of metal that can do work.

MAGNETIC LATCH SOLENOID - A magnetic latch solenoid is an electrical component that is activated by electricity and held latch by a permanent magnet. It has two coils (latch and unlatch) that make electromagnet when current flows through them. It also has an internal switch that places the latch coil circuit open at the time the coil latches.

