

Schematic

3408E and 3412E Engines Electrical System

99C1-UP
80M1-UP

© 2011 Caterpillar, All Rights Reserved

Printed in U.S.A.

Component Identifiers (CID) Module Identifier (MID) Engine Control Module (MID No. 036)	
CID	Component
1	Injector Cylinder 1
2	Injector Cylinder 2
3	Injector Cylinder 3
4	Injector Cylinder 4
5	Injector Cylinder 5
6	Injector Cylinder 6
7	Injector Cylinder 7
8	Injector Cylinder 8
9	Injector Cylinder 9
10	Injector Cylinder 10
11	Injector Cylinder 11
12	Injector Cylinder 12
42	Injector Actuation Valve
91	Throttle Switch
100	Engine Oil Pressure Sensor
110	Engine Coolant Temperature Sensor
164	Injector Actuation Pressure Control Valve
168	System Voltage High
172	Intake Manifold Air Temp Sensor
174	Fuel Temperature Sensor
175	Engine Oil Temperature Sensor
190	Engine Speed Sensor
248	Cat Data Link
253	Personality Module
254	Electronic Control Module
261	Engine Timing Calibration
262	5 Volt Sensor Dc Power
263	Digital Sensor Supply
264	Decel Throttle Position
266	Crack Without Injection Input
268	Programmed Parameter Fault
273	Manifold Pressure Sensor
274	Atmospheric Pressure Sensor
275	Right Turbo Inlet Pressure Sensor
277	Timing Calibration Sensor
291	Engine Cooling Fan Solenoid
342	Secondary Engine Speed Sensor
544	Engine Cooling Fan Speed Sensor
545	Ether Injection Control Relay
596	Implement Control
799	Service Tool
1599	Engine Fan Blade Position Pull Solenoid
1600	Engine Fan Blade Position Push Solenoid

*The CID is a diagnostic code that indicates which circuit is faulty.
*The MID is a diagnostic code that indicates which electronic control module diagnosed the fault.

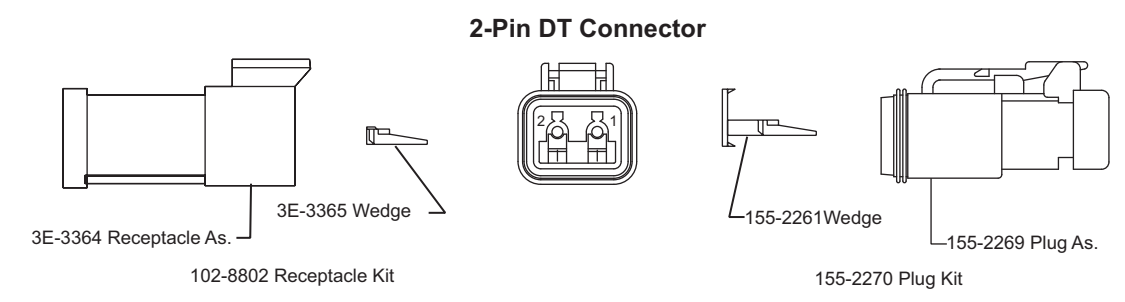

Wire Gauge	Pin #	Socket #
14	9W-0852	9W-0844
16 - 18	8T-8729	8T-8730

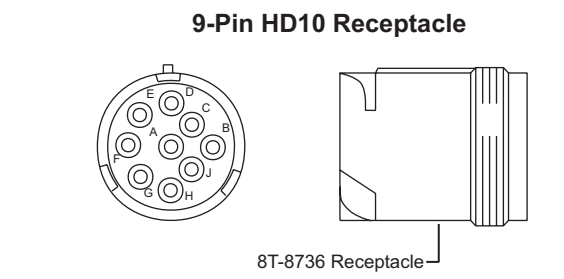

Wire Gauge	Pin #	Socket #
14	9W-0852	9W-0844
16 - 18	8T-8729	8T-8730

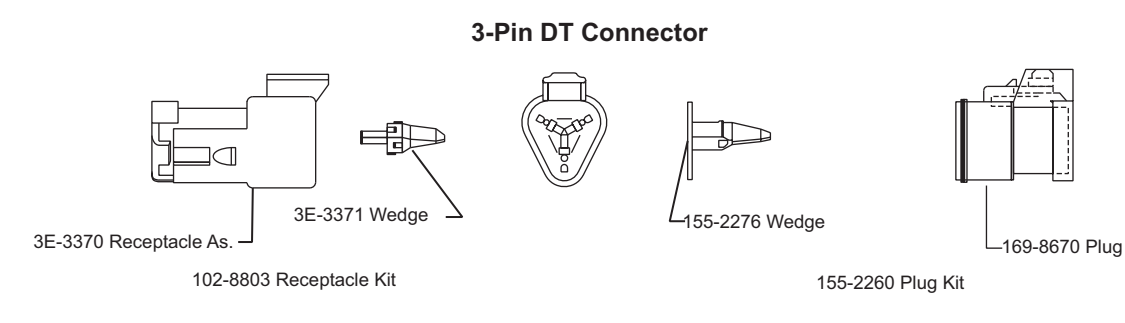

Wire Gauge	Pin #	Socket #
14	9W-0852	9W-0844
16 - 18	8T-8729	8T-8730

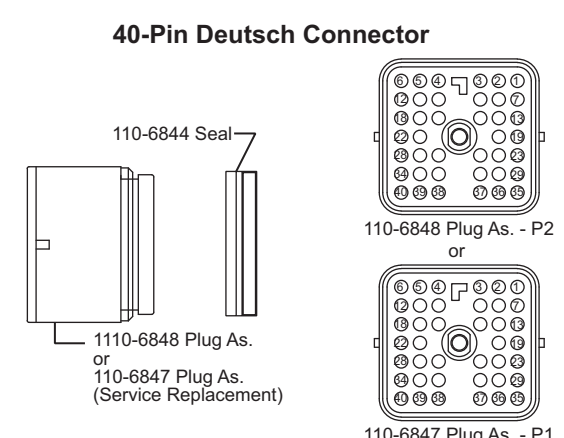

Wire Gauge	Socket #
14	9W-0844
16 - 18	8T-8730

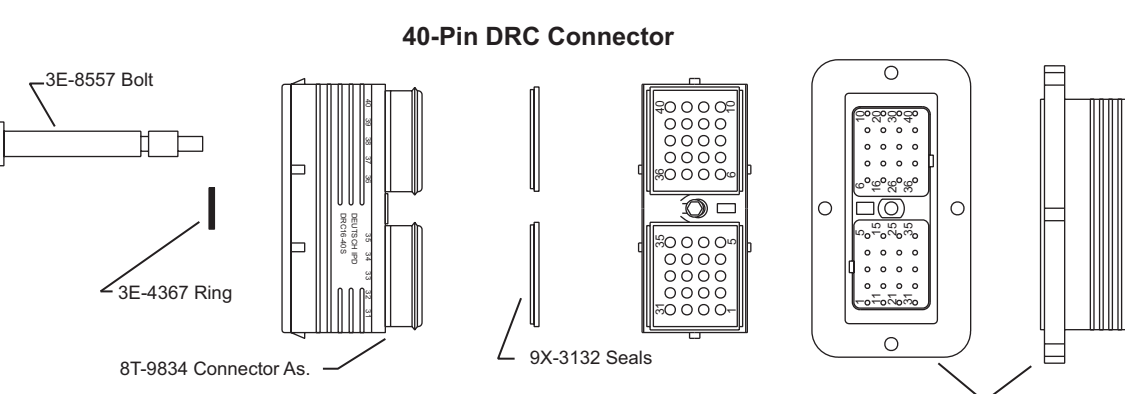

Wire Gauge	Pin #	Socket #
14	9W-0852	9W-0844
16 - 18	8T-8729	8T-8730

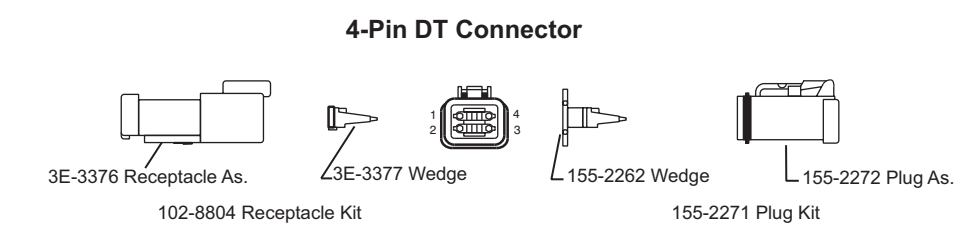

Wire Gauge	Pin #	Socket #
14	9W-0852	9W-0844
16 - 18	8T-8729	8T-8730

CONNECTORS

CONNECTORS

Harness And Wire Electrical Schematic Symbols

Symbols

Pressure Symbol **Temperature Symbol** **Level Symbol** **Flow Symbol** **Circuit Breaker Symbol**

Symbols and Definitions

Fuse: A component in an electrical circuit that will open the circuit if too much current flows through it.

Switch (Normally Open): A switch that will close at a specified point (temp, press, etc.). The circle indicates that the component has screw terminals and a wire can be disconnected from it.

Switch (Normally Closed): A switch that will open at a specified point (temp, press, etc.). No circle indicates that the wire cannot be disconnected from the component.

Ground (Wired): This indicates that the component is connected to a grounded wire. The grounded wire is fastened to the machine.

Ground (Case): This indicates that the component does not have a wire connected to ground. It is grounded by being fastened to the machine.

Reed Switch: A switch whose contacts are controlled by a magnet. A magnet closes the contacts of a normally open reed switch; it opens the contacts of a normally closed reed switch.

Sender: A component that is used with a temperature or pressure gauge. The sender measures the temperature or pressure. Its resistance changes to give an indication to the gauge of the temperature or pressure.

Relay (Magnetic Switch): A relay is an electrical component that is activated by electricity. It has a coil that makes an electromagnet when current flows through it. The electromagnet can open or close a valve or move a piece of metal that can do work.

Solenoid: A solenoid is an electrical component that is activated by electricity. It has a coil that makes an electromagnet when current flows through it. The electromagnet can open or close a valve or move a piece of metal that can do work.

Magnetic Latch Solenoid: A magnetic latch solenoid is an electrical component that is activated by electricity and held latched by a permanent magnet. It has two coils (latch and unlatch) that make electromagnet when current flows through them. It also has an internal switch that places the latch coil circuit open at the time the coil latches.

Harness and Wire Symbols

Wire, Cable, or Harness Assembly Identification: Includes Harness Identification Letters and Harness Connector Serialization Codes (see sample).

Part Number: for Connector Plug

Part Number: for Connector Receptacle

Part Number: for Connector Pin or Socket Number

Part Number: for Component

Part Number: for Fuse

Part Number: for Wire Gauge

Part Number: for Wire Color

Part Number: for Component

Part Number: for Wire Gauge

Part Number: for Wire Color

Failure Mode Identifiers (FMI)	
FMI No.	Failure Description
0	Data valid but above normal operational range.
1	Data valid but below normal operational range.
2	Data erratic, intermittent, or incorrect.
3	Voltage above normal or shorted high.
4	Voltage below normal or shorted low.
5	Current below normal or open circuit.
6	Current above normal or grounded circuit.
7	Mechanical system not responding properly.
8	Abnormal frequency, pulse width, or period.
9	Abnormal update.
10	Abnormal rate of change.
11	Failure mode not identifiable.
12	Bad device or component.
13	Out of calibration.
14	Parameter failures.
15	Parameter failures.
16	Parameter not available.
17	Module not responding.
18	Sensor supply fault.
19	Condition not met.
20	Parameter failures.

*The FMI is a diagnostic code that indicates what type of failure has occurred.

Event Codes Engine Control	
Event Code	Condition
E017	High Engine Coolant Temperature Warning
E025	High Inlet Air Temperature Derate
E027	High Inlet Air Temperature Warning
E100	Low Engine Oil Pressure Warning
E164	High Injector Actuation Pressure
E190	Engine Overspeed Warning
E265	User Defined Shutdown
E272	Inlet Air Restriction Warning

Related Electrical Service Manuals	
Title	Form Number
Engine Control	SENR2945-05

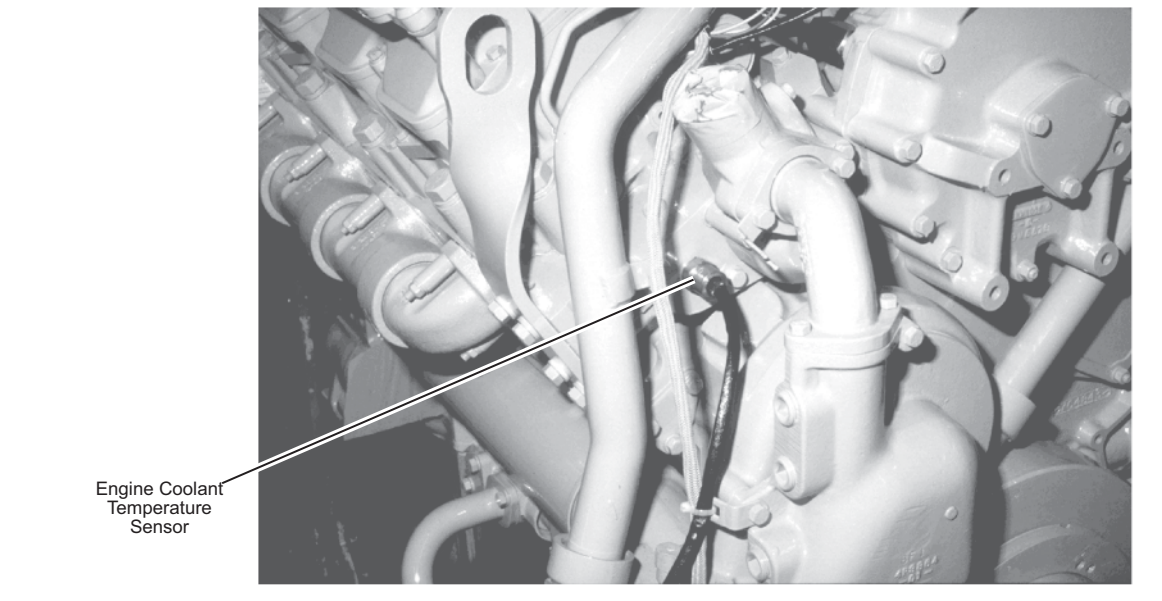
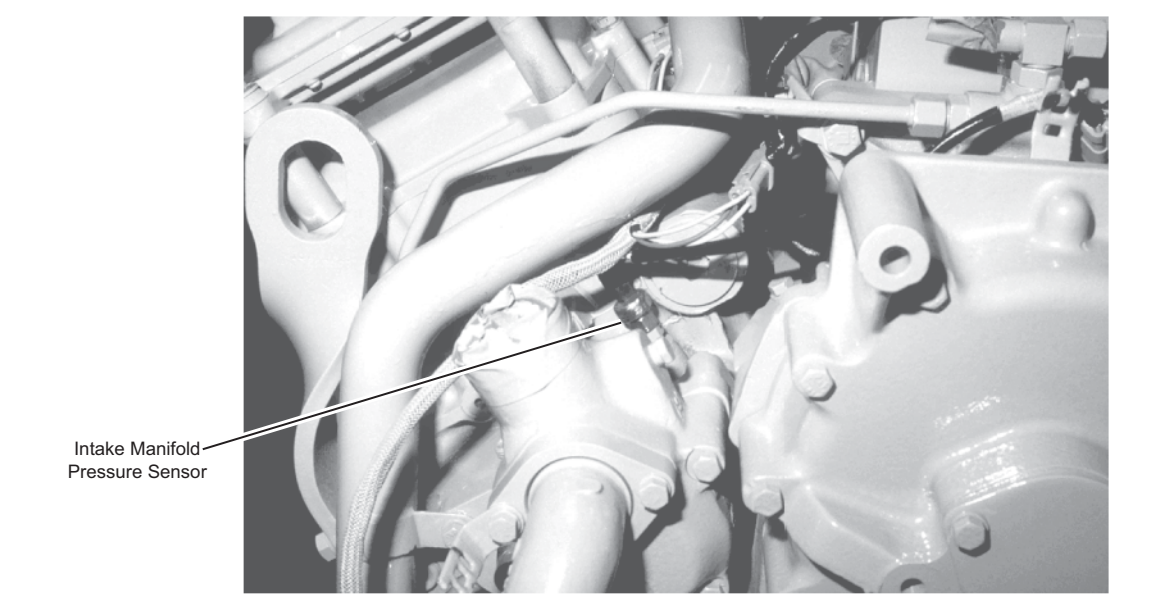
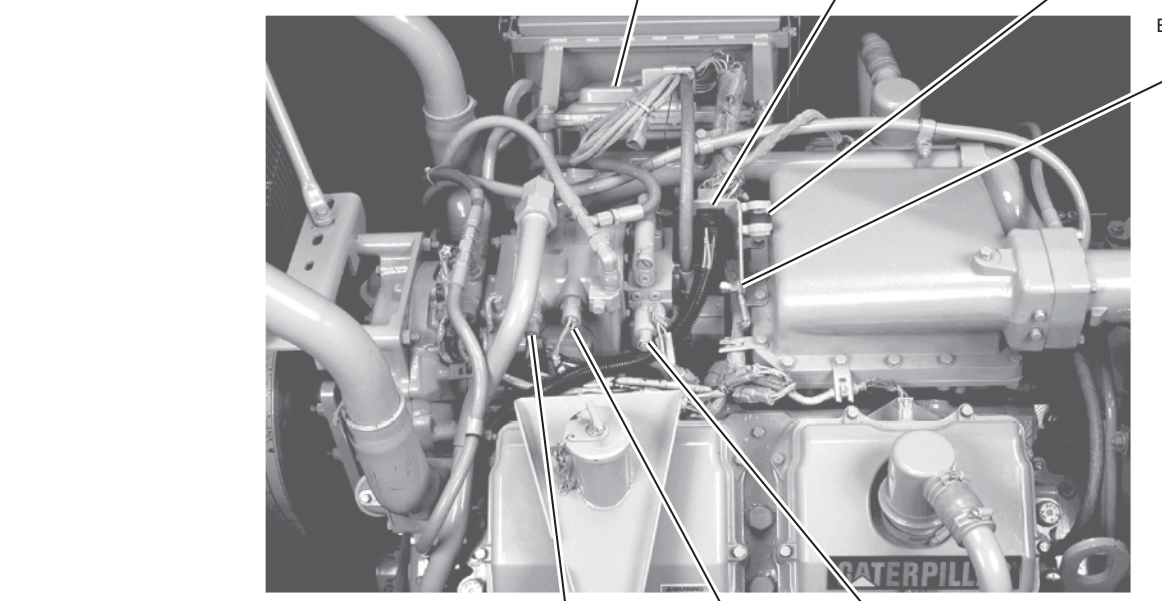
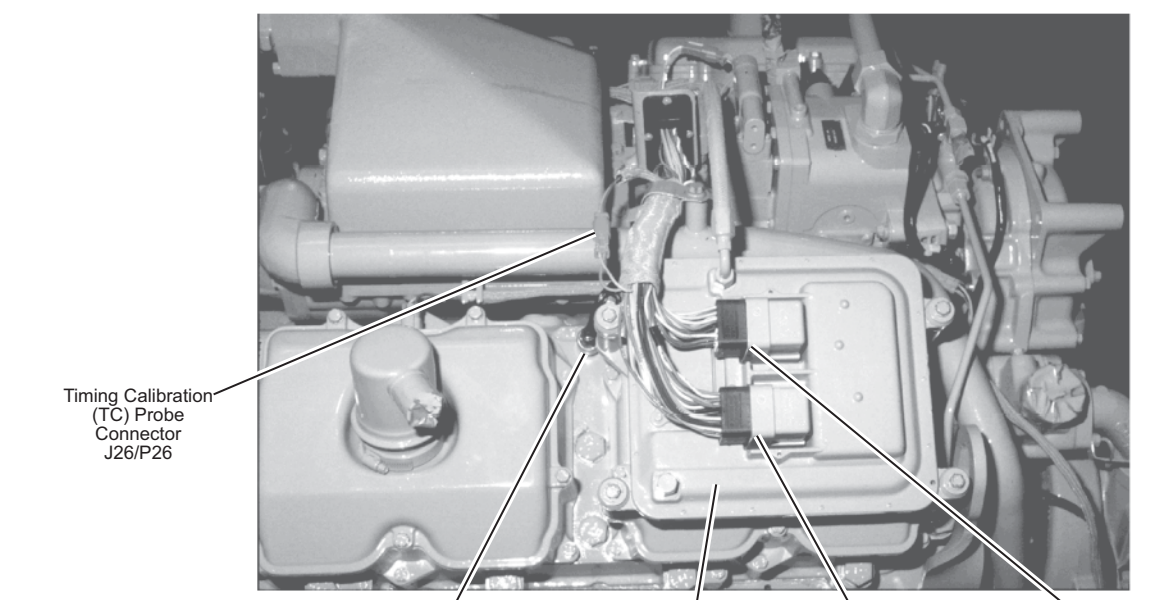
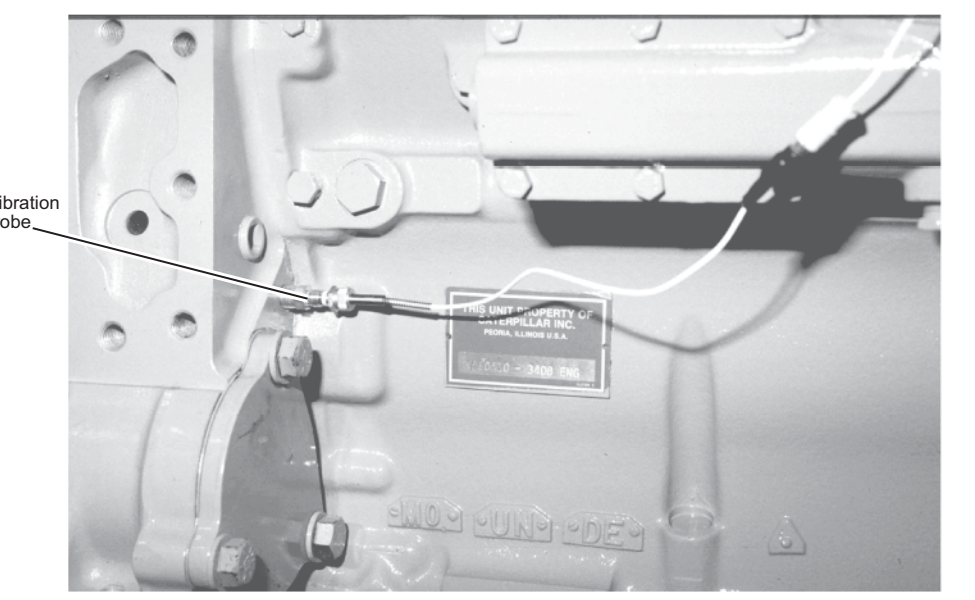
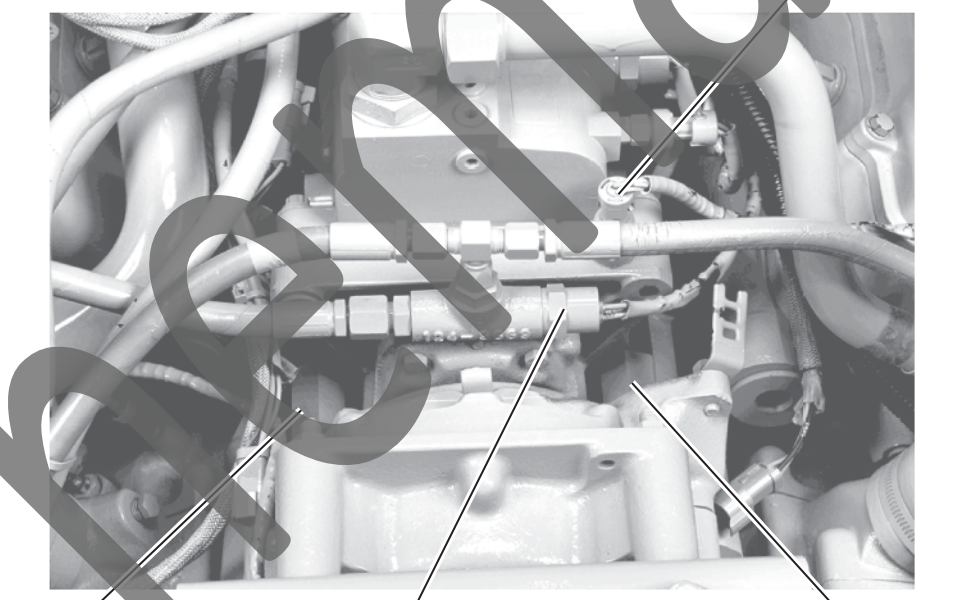
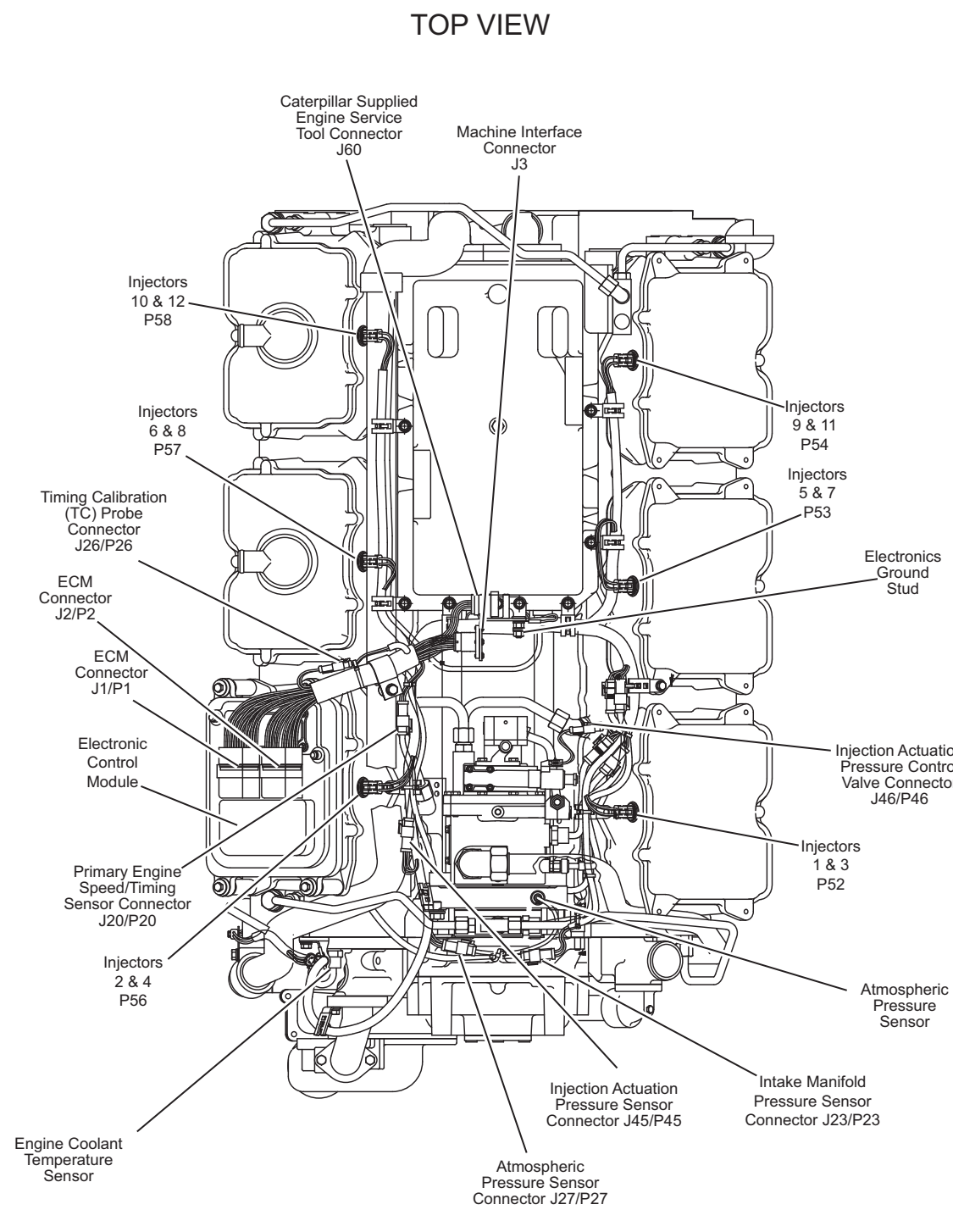

3412E ENGINE INJECTOR SOLENOID CONNECTIONS ONLY

3408E ENGINE INJECTOR SOLENOID CONNECTIONS ONLY

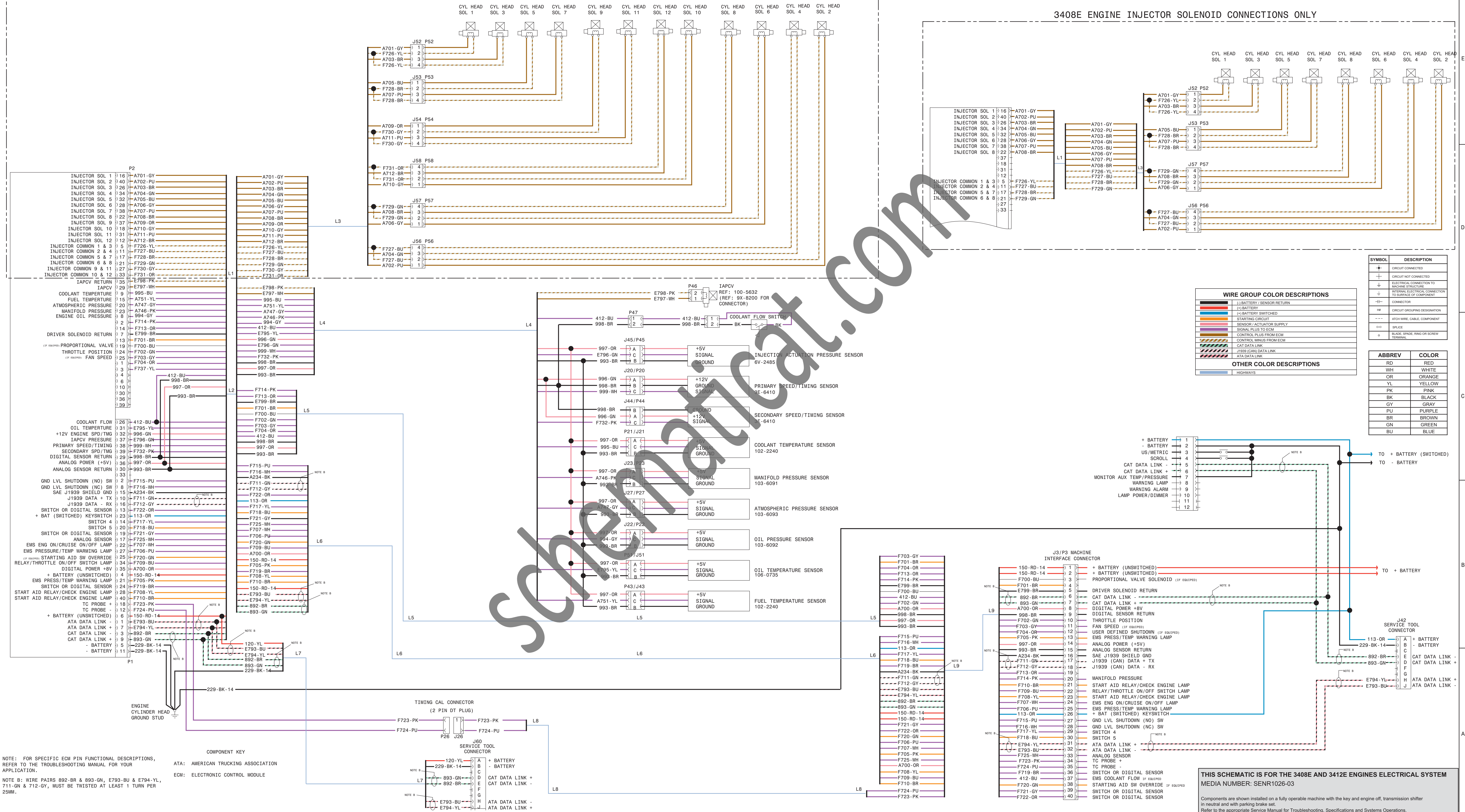

Wiring Label	Color	Wiring Label	Color
INJECTOR SOL 1	A701-GY	A701-GY	
INJECTOR SOL 2	A702-PU	A702-PU	
INJECTOR SOL 3	A703-BR	A703-BR	
INJECTOR SOL 4	A704-GN	A704-GN	
INJECTOR SOL 5	A705-BU	A705-BU	
INJECTOR SOL 6	A706-GY	A706-GY	
INJECTOR SOL 7	A707-PU	A707-PU	
INJECTOR SOL 8	A708-BR	A708-BR	
INJECTOR SOL 9	A709-OR	A709-OR	
INJECTOR SOL 10	A710-GY	A710-GY	
INJECTOR SOL 11	A711-PU	A711-PU	
INJECTOR SOL 12	A712-BR	A712-BR	
INJECTOR COMMON 1 & 3	F726-YL	F726-YL	
INJECTOR COMMON 2 & 4	F727-BU	F727-BU	
INJECTOR COMMON 5 & 7	F728-BR	F728-BR	
INJECTOR COMMON 6 & 8	F729-GN	F729-GN	
INJECTOR COMMON 9 & 11	F730-GY	F730-GY	
INJECTOR COMMON 10 & 12	F731-OR	F731-OR	
IAPCV RETURN	E798-PK	E798-PK	
IAPCV	E797-WH	E797-WH	
COOLANT TEMPERATURE	995-BU	995-BU	
FUEL TEMPERATURE	A751-YL	A751-YL	
ATMOSPHERIC PRESSURE	A747-GY	A747-GY	
MANIFOLD PRESSURE	A746-PK	A746-PK	
ENGINE OIL PRESSURE	994-GY	994-GY	
DRIVER SOLENOID RETURN	F714-PK	F714-PK	
PROPORTIONAL VALVE THROTTLE POSITION	F713-OR	F713-OR	
FAN SPEED	F703-GY	F703-GY	
COOLANT FLOW	412-BU	412-BU	
OIL TEMPERATURE	E795-YL	E795-YL	
+12V ENGINE SPD/TIM	998-GN	998-GN	
IAPCV PRESSURE	E796-GN	E796-GN	
PRIMARY SPEED/TIMING	999-WH	999-WH	
SECONDARY SPD/TIM	F732-PK	F732-PK	
DIGITAL SENSOR RETURN	998-BR	998-BR	
ANALOG POWER (+5V)	997-OR	997-OR	
ANALOG SENSOR RETURN	993-BR	993-BR	
GND LVL SHUTDOWN (NO) SW	F715-PU	F715-PU	
GND LVL SHUTDOWN (NC) SW	F716-WH	F716-WH	
SAE J1939 SHIELD GND	A234-BK	A234-BK	
J1939 DATA - TX	F711-GN	F711-GN	
J1939 DATA - RX	F712-GY	F712-GY	
SWITCH OR DIGITAL SENSOR	F722-OR	F722-OR	
+ BAT (SWITCHED) KEYSWITCH	113-OR	113-OR	
SWITCH 4	F717-YL	F717-YL	
SWITCH 5	F718-BU	F718-BU	
SWITCH OR DIGITAL SENSOR	F721-GY	F721-GY	
ANALOG SENSOR	F725-WH	F725-WH	
EMS ENG ON/CRUISE ON/OFF LAMP	F706-PU	F706-PU	
EMS PRESS/TEMP WARNING LAMP	F720-GN	F720-GN	
STARTING AID SW OVERRIDE	F709-BU	F709-BU	
RELAY/THROTTLE ON/OFF SWITCH LAMP	A700-OR	A700-OR	
DIGITAL POWER +8V	F719-BR	F719-BR	
+ BATTERY (UNSWITCHED)	150-RD-14	150-RD-14	
EMS PRESS/TEMP WARNING LAMP	F705-PK	F705-PK	
SWITCH OR DIGITAL SENSOR	F710-BR	F710-BR	
START AID RELAY/CHECK ENGINE LAMP	F708-YL	F708-YL	
START AID RELAY/CHECK ENGINE LAMP	F710-BR	F710-BR	
TC PROBE +	F723-PK	F723-PK	
+ BATTERY (UNSWITCHED)	150-RD-14	150-RD-14	
ATA DATA LINK -	E793-BU	E793-BU	
ATA DATA LINK +	E794-YL	E794-YL	
CAT DATA LINK -	893-GN	893-GN	
CAT DATA LINK +	892-BR	892-BR	

WIRE GROUP COLOR DESCRIPTIONS	
(-) BATTERY / SENSOR RETURN	
(+) BATTERY	
(+) BATTERY SWITCHED	
STARTING CIRCUIT	
INTERNAL ELECTRICAL CONNECTION TO SURFACE OF COMPONENT	
EXTERNAL ELECTRICAL CONNECTION TO SURFACE OF COMPONENT	
CONNECTOR	
CIRCUIT GROUP/NO. DESIGNATION	
CONTROL PLUS FROM ECM	
CONTROL MINUS FROM ECM	
CAT DATA LINK -	
J1939 CAN DATA LINK	
ATA DATA LINK	
OTHER COLOR DESCRIPTIONS	
HIGHWAYS	

SYMBOL	DESCRIPTION
+	CIRCUIT CONNECTED
-	CIRCUIT NOT CONNECTED
⊕	ELECTRICAL CONNECTION TO SURFACE OF COMPONENT
⊖	INTERNAL ELECTRICAL CONNECTION TO SURFACE OF COMPONENT
⊗	EXTERNAL ELECTRICAL CONNECTION TO SURFACE OF COMPONENT
⊙	CONNECTOR
⊞	CIRCUIT GROUP/NO. DESIGNATION
---	STITCH WIRE - CABLE COMPONENT
---	SLICE
---	SLASH SPACE, RING OR SCREW TERMINAL

ABBREV	COLOR
RD	RED
WH	WHITE
OR	ORANGE
YL	YELLOW
PK	PINK
BK	BLACK
GY	GRAY
PU	PURPLE
BR	BROWN
GN	GREEN
BU	BLUE

NOTE: FOR SPECIFIC ECM PIN FUNCTION DESCRIPTIONS, REFER TO THE TROUBLESHOOTING MANUAL FOR YOUR APPLICATION.

NOTE B: WIRE PAIRS 892-BR & 893-GN, E793-BU & E794-YL, 711-GN & 712-GY, MUST BE TWISTED AT LEAST 1 TURN PER 25MM.

COMPONENT KEY
ATA: AMERICAN TRUCKING ASSOCIATION
ECM: ELECTRONIC CONTROL MODULE

THIS SCHEMATIC IS FOR THE 3408E AND 3412E ENGINES ELECTRICAL SYSTEM
MEDIA NUMBER: SENR1026-03

Components are shown installed on a fully operable machine with the key and engine off, transmission shifter in neutral and with parking brake set.
Refer to the appropriate Service Manual for Troubleshooting, Specifications and Systems Operations.