

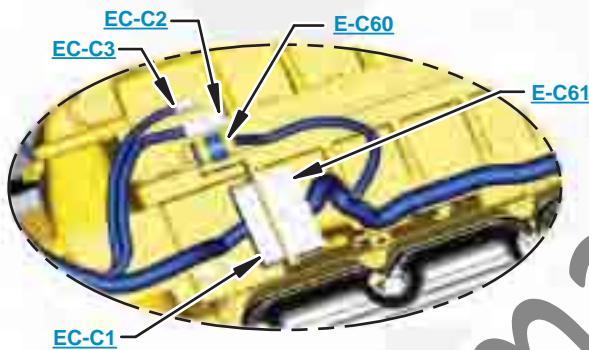

This document is best viewed at a screen resolution of 1024 X 768.

To set your screen resolution do the following:
RIGHT CLICK on the **DESKTOP**.
 Select **PROPERTIES**.
CLICK the **SETTINGS TAB**.
MOVE THE SLIDER under **SCREEN RESOLUTION** until it shows **1024 X 768**.
CLICK OK to apply the resolution.

The Bookmarks panel will allow you to quickly navigate to points of interest.



Click on any text that is BLUE and underlined. These are hyperlinks that can be used to navigate the schematic and machine views.

VIEW ALL CALLOUTS

When only one callout is showing on a machine view this button will make all of the callouts visible. This button is located in the top right corner of every machine view page.

HOTKEYS (Keyboard Shortcuts)		
	FUNCTION	KEYS
	Zoom In	"CTRL" / "+"
	Zoom Out	"CTRL" / "-"
	Fit to Page	"CTRL" / "0" (zero)
	Hand Tool	"SPACEBAR" (hold down)
	Find	"CTRL" / "F"



Schematic

725 and 730 Articulated Truck Hydraulic System

725:**WWA1-UP****B1L1-UP****AFX1179-1648****730:****WWB1-UP****AGF1092-1561****B1M1-UP****Hoist, Steering, Suspension, and Fan Drive**

COMPONENT LOCATION

Page 1 of 2



Description	Part Number		Machine Location	Schematic Location
	AGF / AFX	B1L / B1M		
Accumulator Gp - Brake	236-7794	236-7794	2	E-8
Accumulator Gp - Park Brake	163-5632	163-5632	1	F-7
Body - Drain Valve	8J-8782	8J-8782	6	A-5
Brake Gp - Parking	160-8009	160-8009	3	F-8
Brake Gp - Service	159-7596	159-7596	4	B-1, C-1, C-9, D-9
Breather Gp - Hydraulic Tank	160-5615	160-5615	6	A-5
Cylinder Gp - Suspension	200-4300	200-4300	10	A-3, F-3
Cylinder Gp - Hoist: 725 730	241-4071 241-4062	285-4031 285-4032	7	D-1, F-1
Cylinder Gp - Steering: Left Right	215-3024 215-3023	273-3267 273-3266	8	D-2
Filter Element As. - Oil	132-8876	132-8876	6	A-4
Fitting As - Male	164-5567	164-5567	9	E-1
Manifold - Hoist	156-4504	156-4504	9	E-2
Manifold - Press. Switch	230-3008	230-3008	11	E-9
Manifold - Service Brake	7U-9277	7U-9277	12	B-1, C-1, C-9
Motor - Fan Drive	240-6746	240-6746	14	F-9
Pump and Motor Gp - Sec. Str	173-8787	253-8095	1	C-4
Pump Gp - Fan, Brake, Hoist	240-2647	240-2647	15	C-7
Pump Gp - Steering, Hoist	240-2647	240-2647	16	C-5
Pump Group - Metering	223-7718	223-7718	17	D-3
Screen - Main Control Valve	6E-5066	6E-5066	18	E-6, F-7
Screen - Hydr. Tank Supply	119-4885	119-4885	6	A-5
Screen As. - Hydr. Tank Fill	6J-3795	6J-3795	6	A-4
Switch As - Diff. Press. Hydr.	117-7773	117-7773	6	A-4
Switch As - Parking Press.	172-7073	213-6947	18	F-7
Switch As - Press., Stop Light	172-7071	172-7071	11	E-9
Switch As - Press., Xmsn	172-7071	172-7071	11	E-9
Switch As. - Low Brake Press.	3E-7688	266-6477	18	F-7
Switch As. - Press., Steering Oil	3E-6450	3E-6450	18	D-6
Tank Gp - Hydraulic	234-5600	234-5600	6	A-4
Valve - Fluid Sampling	8C-3446	8C-3446	22	B-4

COMPONENT LOCATION

Page 2 of 2



Description	Part Number		Machine Location	Schematic Location
	AGF / AFX	B1L / B1M		
Valve Gp - Main Control	240-0678	240-0678	18	F-5
Valve Gp - Brake Control	224-3207	224-3207	20	D-9
Valve Gp - Check 1	128-2780	128-2780	18	D-5
Valve Gp - Check 2	128-2780	128-2780	18	E-6
Valve Gp - Check 3	158-9956	158-9956	18	F-6
Valve Gp - Check 4	194-1723	194-1723	18	D-5
Valve Gp - Check 5	239-0617	239-0617	18	D-5
Valve Gp - Check 6	239-0617	239-0617	18	D-6
Valve Gp - Check 7	252-6485	252-6485	18	E-6
Valve Gp - Check	145-8983	145-8983	6	B-4
Valve Gp - Check Hydr. Tank	239-1132	Not Used	6	B-4
Valve Gp - Control Valve	241-4680	281-3307	19	F-3
Valve Gp - Diverter 1	239-0594	239-0594	18	D-6
Valve Gp - Diverter 2	239-0603	239-0603	18	E-6
Valve Gp - Diverter 3	239-0605	239-0605	18	D-6
Valve Gp - Diverter 4	239-0621	239-0621	18	F-6
Valve Gp - Pressure Reducing	239-0615	239-0615	18	E-6
Valve Gp - Relief 1	241-6256	241-6256	18	F-3
Valve Gp - Relief 2	239-0612	239-0612	18	F-6
Valve Gp - Relief 3	239-0614	239-0614	18	F-5
Valve Gp - Relief, Steer Cyl.	214-9055	268-5823	21	D-2, E-2
Valve Gp - Shuttle 1	239-0618	239-0618	18	D-5
Valve Gp - Shuttle 2	239-0618	239-0618	18	D-6
Valve Gp - Shuttle 3	239-0618	239-0618	18	E-6
Valve Gp - Shuttle 4	257-8414	257-8414	18	F-6
Valve Gp - Solenoid	235-4605	257-0267	23	E-3, F-3
Valve Gp - Solenoid 1	191-7785	191-7785	18	E-6
Valve Gp - Solenoid 2	201-0950	201-0950	18	F-7

TAP LOCATION



Tap Number	Description	Schematic Location
AA	Hoist Raise & Lower Pressure	E-5
BB	Steer Pressure	D-5
CC	Hoist Pilot Pressure	E-5
DD	Front Brake Pressure	D-9
EE	Steer & Hoist Pump Pressure	C-6
FF	Fan Drive Pressure	E-7
GG	Brake Accumulator Charge Pressure	E-7
HH	Park Brake Pressure	F-7
JJ	Otg. Lube & Diff. Lock Pressure	Not Shown
KK	Fan, Brake, & Hoist Pump Pressure	D-6
NN	Rear Brake Pressure	C-2
PP	Scheduled Oil Sampling	B-4
RR	Body Over Center-Service Point	E-1
TT	Pump Case Fill	B-6, B-5

FLUID POWER SYMBOLS



BASIC COMPONENT SYMBOLS

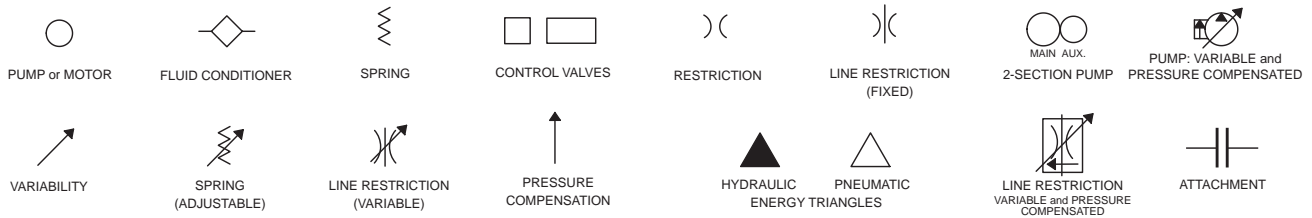

VALVE ENVELOPES

VALVES

VALVE PORTS



CONTROL VALVES

CHECK VALVES

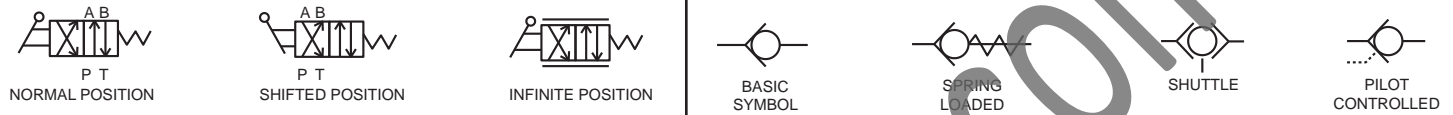

FLUID STORAGE RESERVOIRS



MEASUREMENT

ROTATING SHAFTS



COMBINATION CONTROLS



MANUAL CONTROL SYMBOLS



RELEASED PRESSURE

PILOT CONTROL SYMBOLS

REMOTE SUPPLY PRESSURE

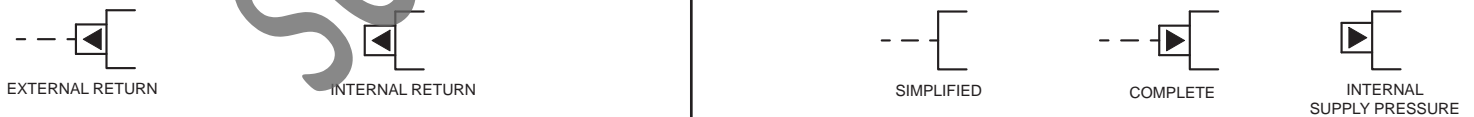

ACCUMULATORS

CROSSING AND JOINING LINES

HYDRAULIC AND PNEUMATIC CYLINDERS

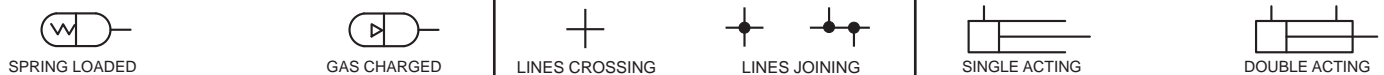

HYDRAULIC PUMPS

HYDRAULIC MOTORS

INTERNAL PASSAGEWAYS

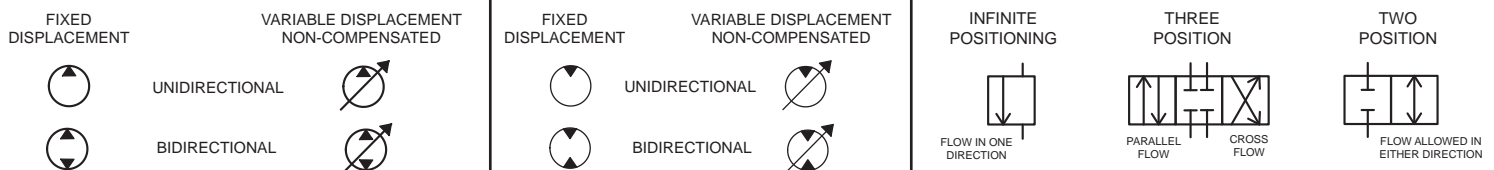

ELECTRICAL SYMBOLS



Hydraulic Symbols (Electrical)



Transducer
(Fluid)

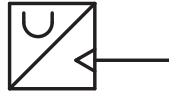

Transducer
(Gas / Air)



Generator



Electric Motor

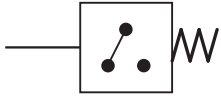

Pressure Switch

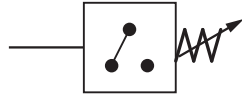

Pressure Switch
(Adjustable)

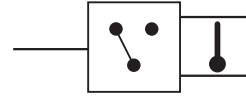

Temperature Switch



Electrical Wire

Electrical Symbols (Electrical)

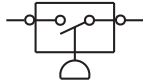

Pressure
Symbol

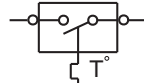

Temperature
Symbol



Level
Symbol

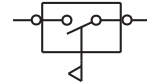

Flow
Symbol

Wire Number Identification Codes

Electrical Schematic Example

Current Standard

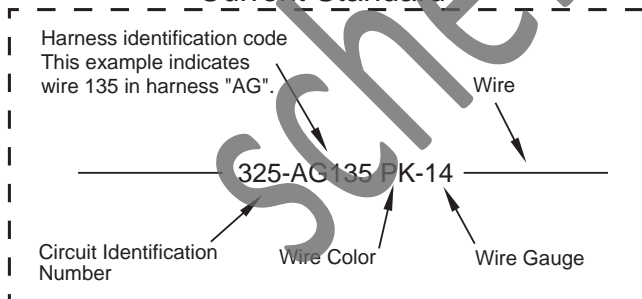

Previous Standard

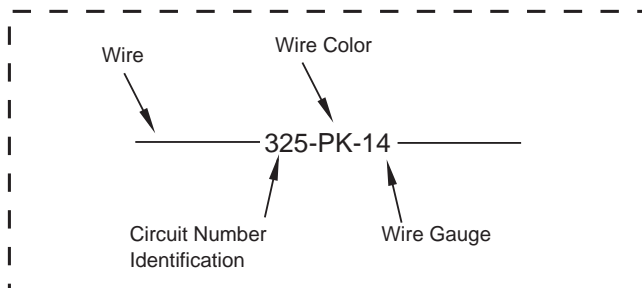

Hydraulic Schematic Example

Current Standard

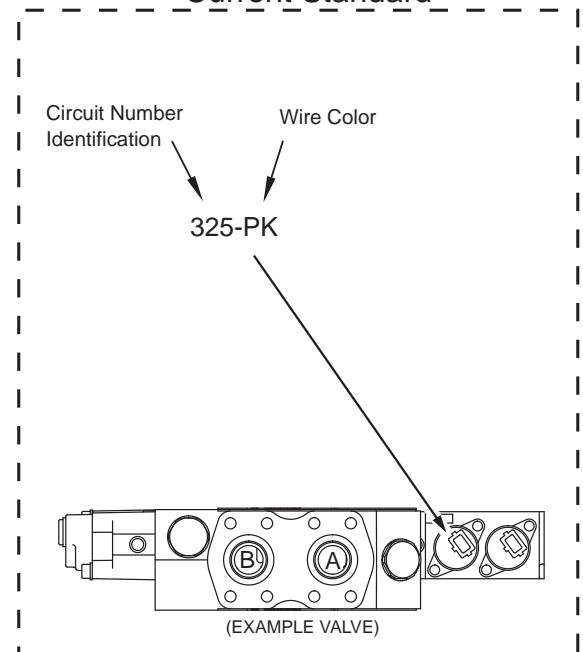

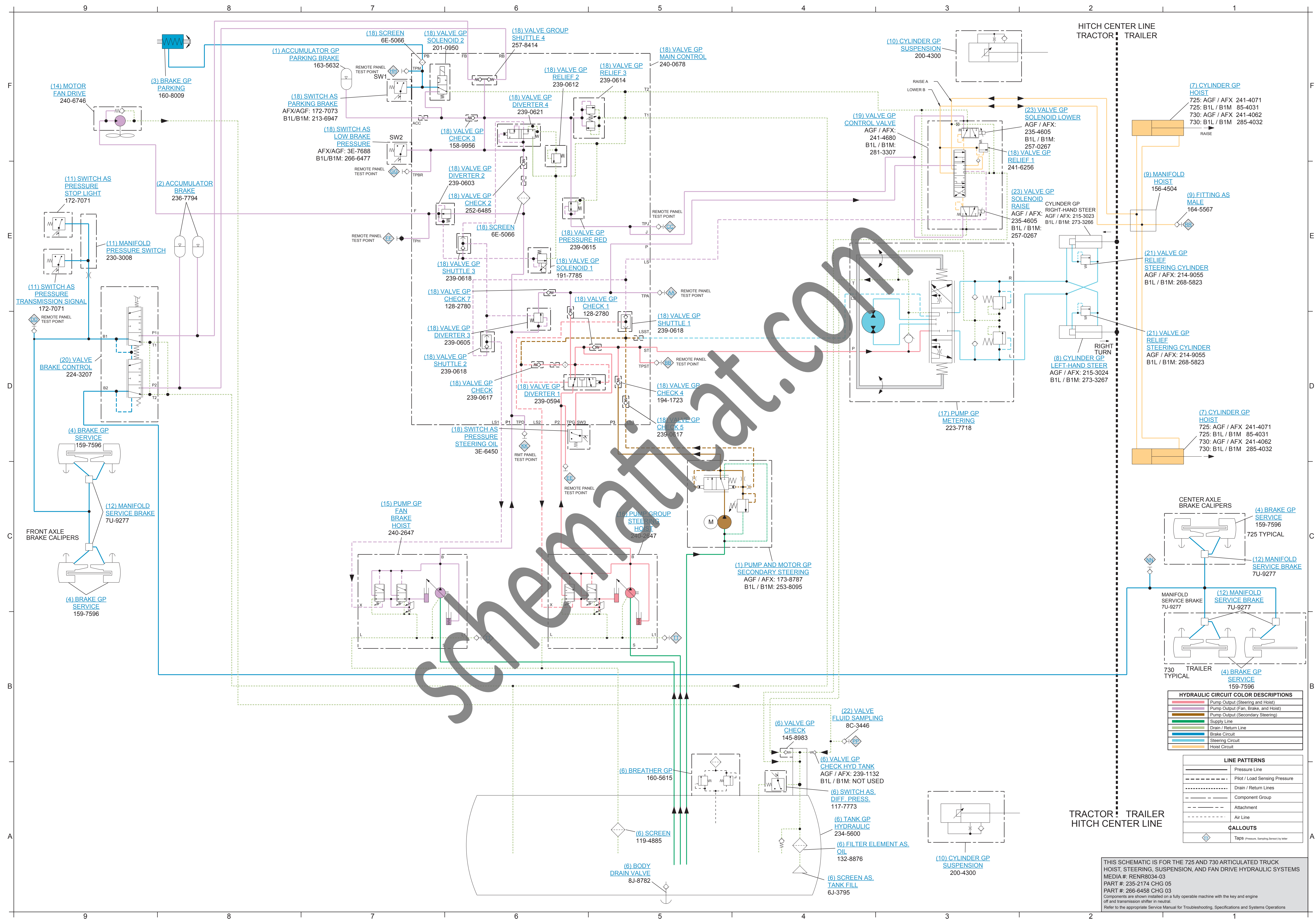

HYDRAULIC CIRCUIT COLOR DESCRIPTIONS	
—	Pump Output (Steering and Hoist)
—	Pump Output (Fan, Brake, and Hoist)
—	Pump Output (Secondary Steering)
—	Supply Line
—	Drain / Return Line
—	Brake Circuit
—	Steering Circuit
—	Hoist Circuit

LINE PATTERNS	
 	Pressure Line
 	Pilot / Load Sensing Pressure
 	Drain / Return Lines
	Component Group
	Attachment
	Air Line

CALLOUTS	
 	TapS (Pressure, Sampling, Sensor) or Meter

THIS SCHEMATIC IS FOR THE 725 AND 730 ARTICULATED TRUCK HOIST, STEERING, SUSPENSION, AND FAN DRIVE HYDRAULIC SYSTEMS
 MEDIA #: RENR8034-03
 PART #: 235-2174 CHG 05
 PART #: 266-6458 CHG 03
 Components are shown installed on a fully operable machine with the key and engine off and transmission shifter in neutral.
 Refer to the appropriate Service Manual for Troubleshooting, Specifications and Systems Operations

MACHINE COMPONENT AND TAP LOCATIONS

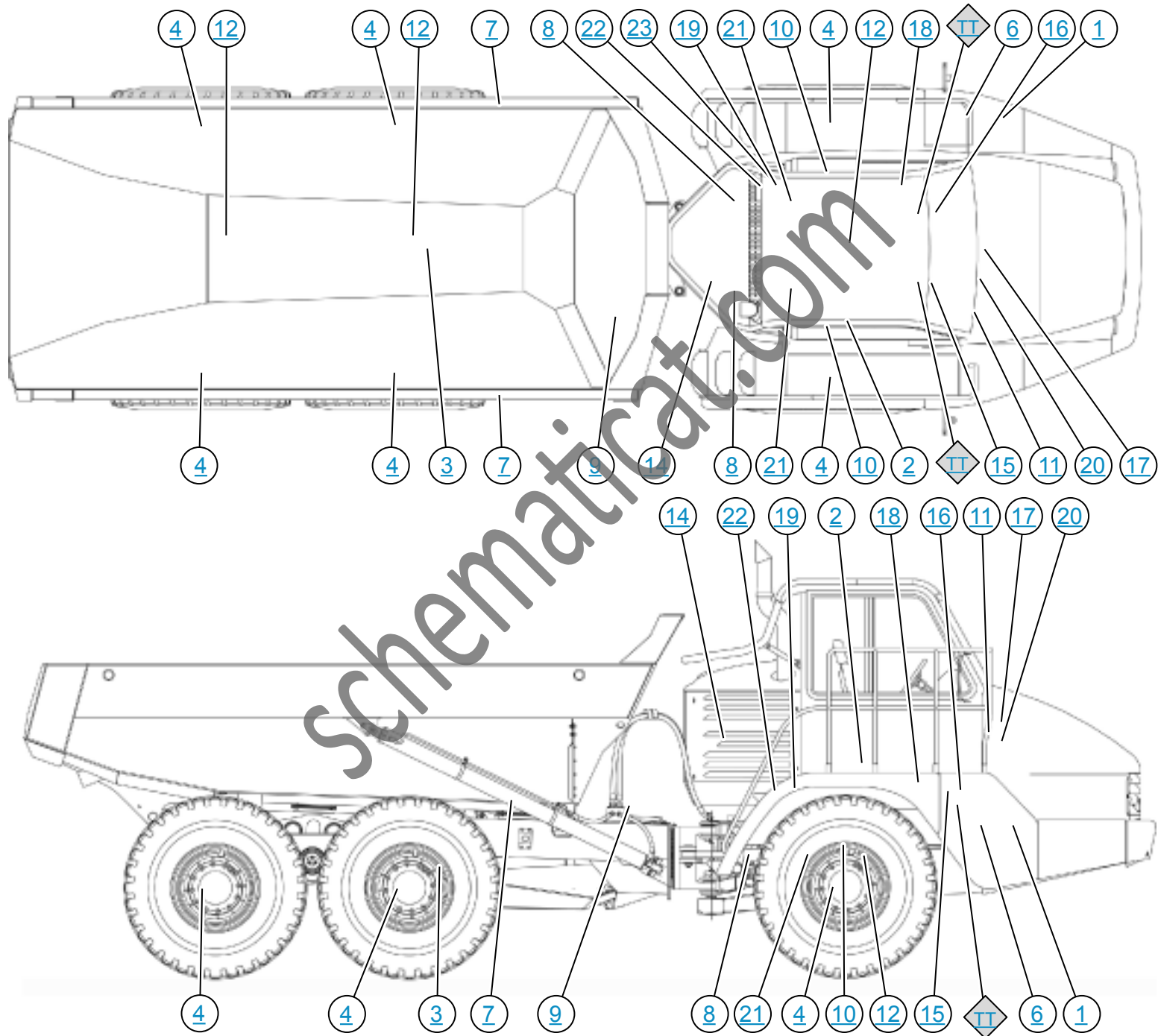

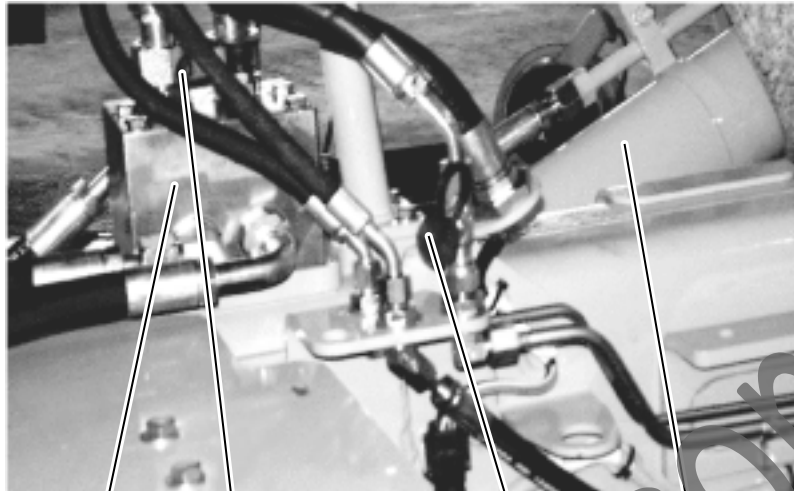

9

RR

NN

7

HOIST MAINFOLD

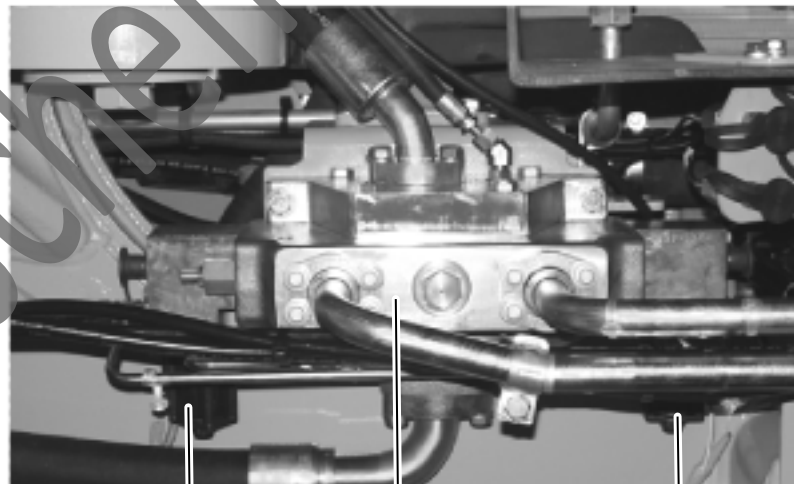

23

19

23

HOIST CONTROL VALVE

DIFFERENTIAL PRESSURE SWITCH



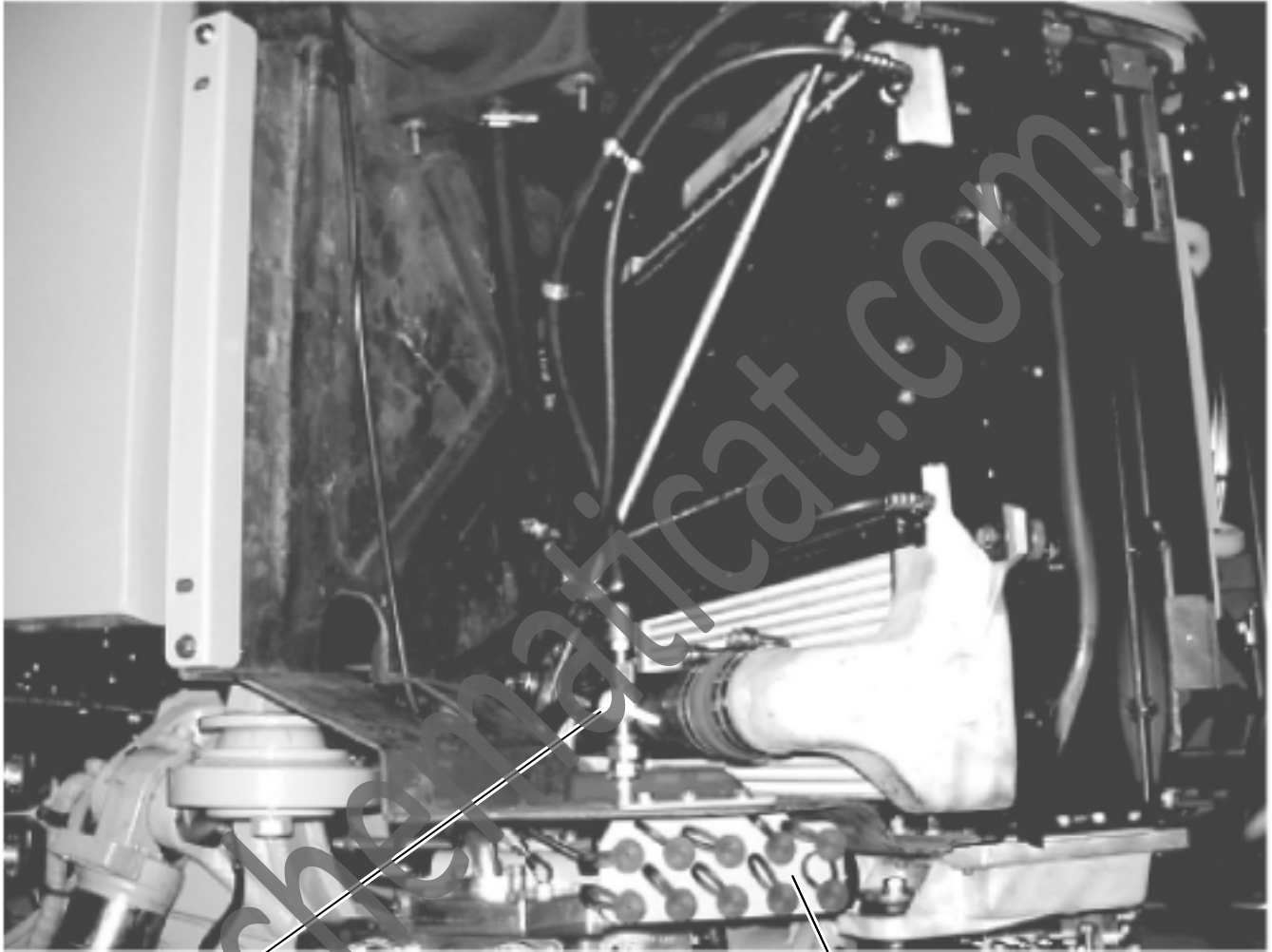

REMOTE DIAGNOSTICS
AND TEST PANEL

REMOTE DIAGNOSTIC AND TEST PORT PANEL LOCATIONS

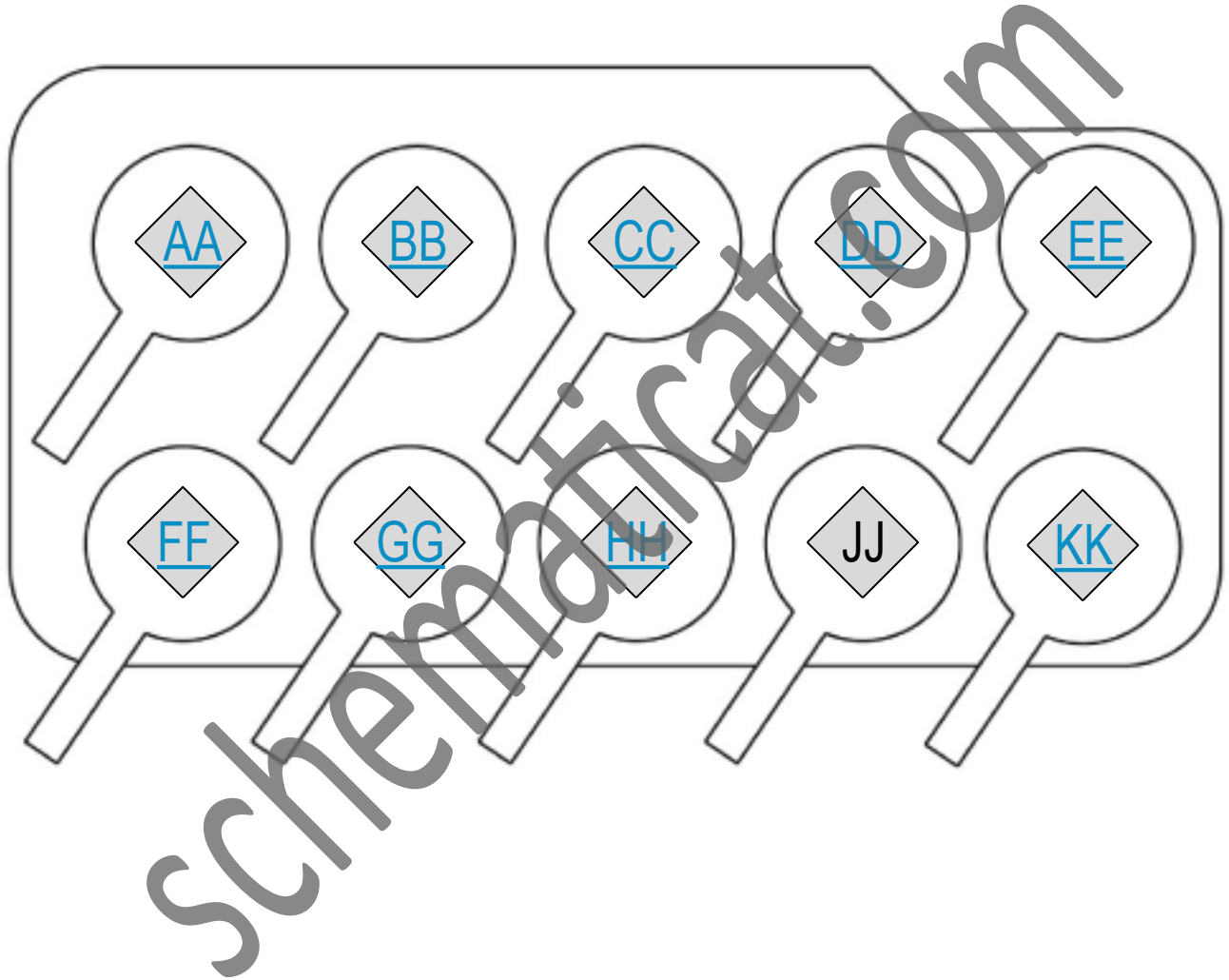

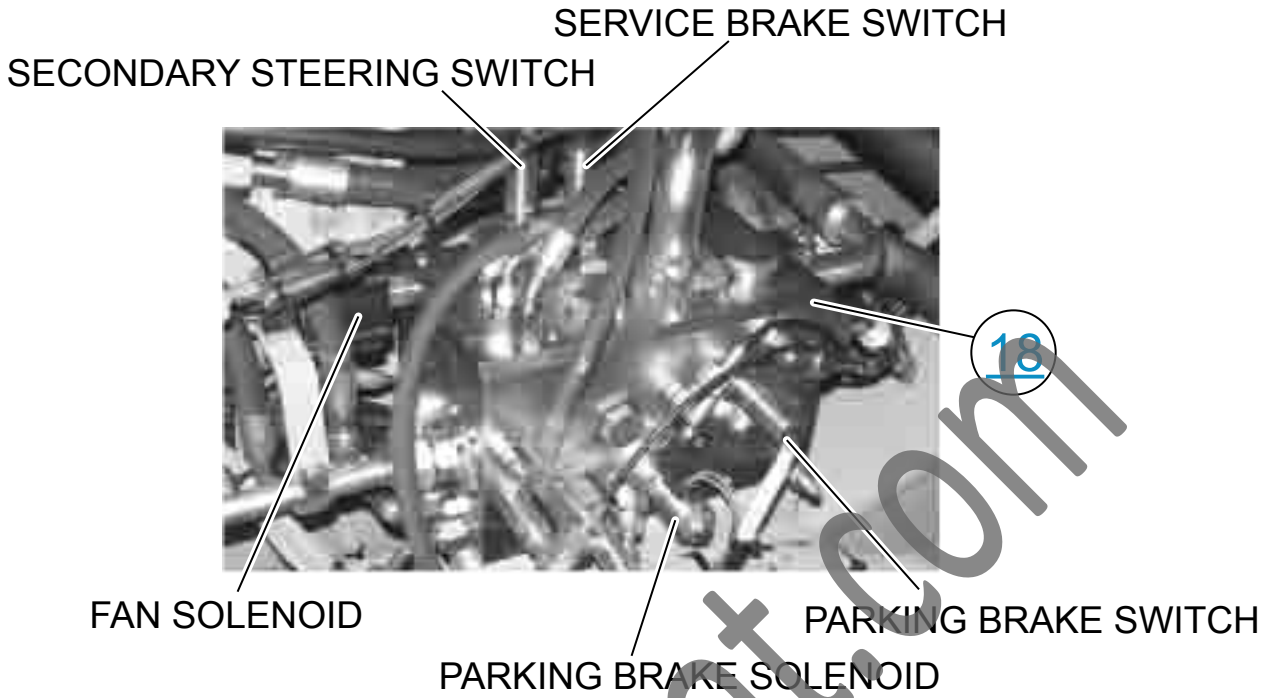

Main Control Valve

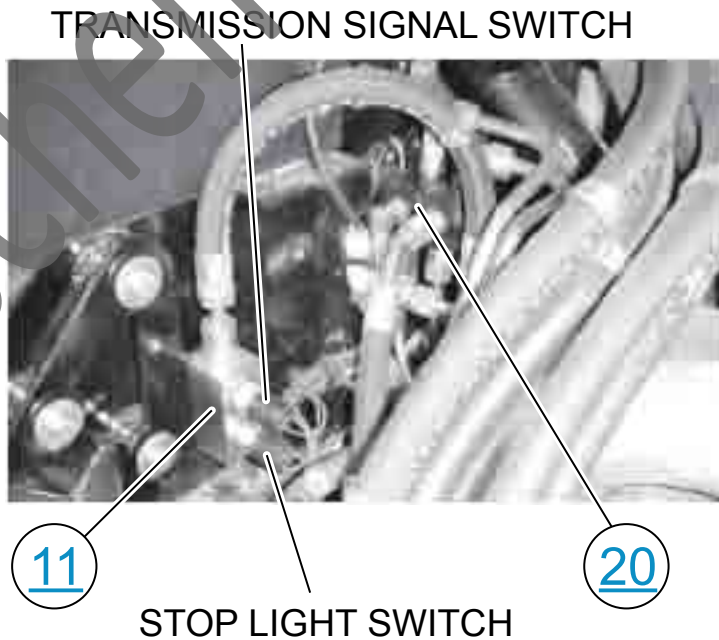

BRAKE MANIFOLD AND CONTROL VALVE