

Schematic

740B Ejector Articulated Truck Hydraulic System

L4F1-UP
T4S1-UP

© 2011 Caterpillar. All Rights Reserved

Printed in U.S.A.

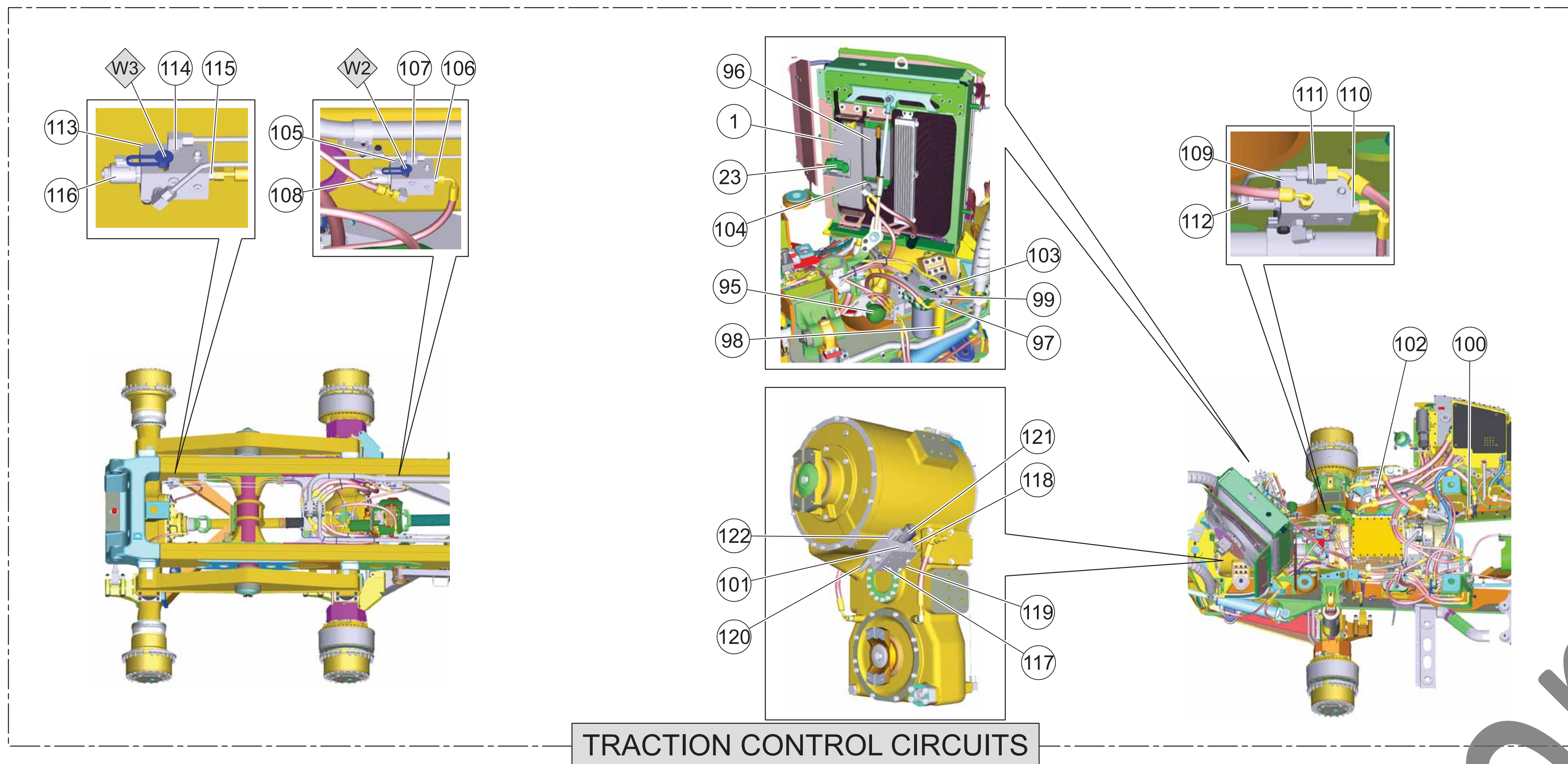
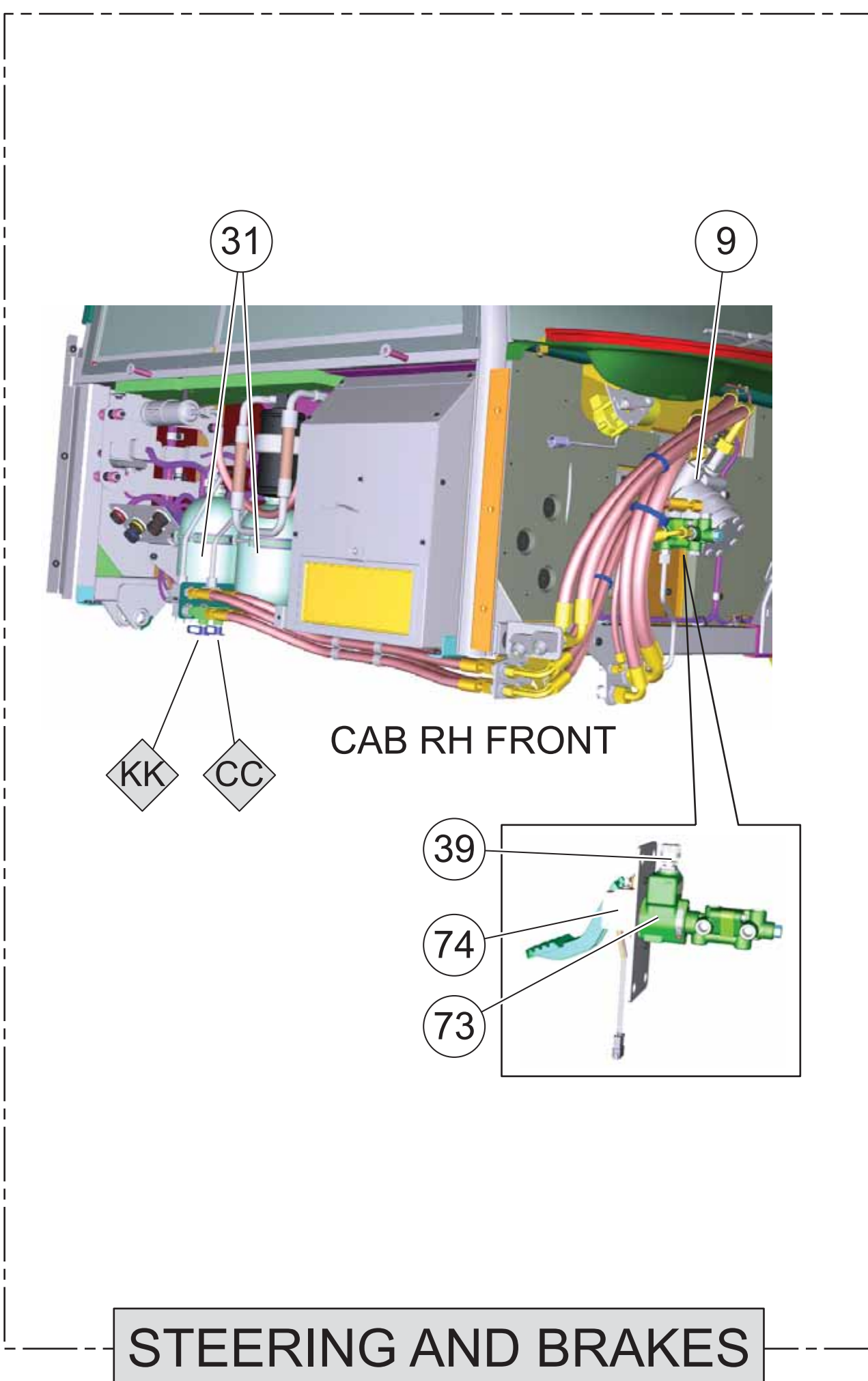

Component Location			
Description	Part Number	Machine Location	Schematic Location
Steering and Brake Circuits			
Core Oil - Hydraulic Oil Cooler	3484933	1	C-3
Control Sp. - Steering (Left)	2511535	2	C-1
Control Sp. - Steering (Right)	2511535	3	E-1
Motor Sp. - Hydraulic Fan (ATAC)	17471202	4	D-1
Motor Sp. - Hydraulic Fan (ATAC)	2451528	4	D-1
Motor Sp. - Hydraulic Fan (ATAC)	3385711	5	D-3
Pump & Motor Sp. - Secondary Steering	2402917	6	C-4
Pump Sp. - Hydraulic Fan	3484932	7	D-5
Pump Sp. - Hydraulic Fan (ATAC)	17471202	8	C-7
Pump Sp. - Hydraulic Fan (ATAC)	2451528	8	C-7
Pump Sp. - Steering	3484935	10	D-6
Pressure Sp. - Hydraulic ATAC Fan Motor	2642448	11	D-1
Pressure Sp. - Hydraulic ATAC Fan Motor	2642448	12	C-3
Pressure Sp. - Hydraulic ATAC Fan Motor	2584633	13	B-5
Pressure Sp. - Hydraulic ATAC Fan Motor	2584633	14	C-5
Switch Sp. - Pressure (Rear Br. Pass. (Steer / Fan))	2532973	15	C-4
Valve Sp. - Hydraulic Oil (Steer / Fan)	1524953	16	B-3
Body - Valve (Steer / Fan)	1524953	17	B-3
Filter Element As. - Steer Tank	1744983	26	E-4
Screen As. - Hydraulic Oil (Steer Tank)	1524953	21	B-3
Valve Sp. - Hydraulic Oil (Steer Tank)	1524953	22	B-3
Valve As. - Control Hydraulic Oil Temperature	3005004	23	C-3
Valve As. - Fluid Sampling (Steer / Fan)	1540000	24	C-3
Valve Sp. - Check (Flow Control (Steering Return))	1540000	25	C-4
Valve Sp. - Check (Secondary Steering Pump (LS))	1657948	26	C-4
Valve Sp. - Check (Steering Pump (LS))	1657948	27	D-6
Valve Sp. - Check (Steering)	1785991	28	F-5
Valve Sp. - Control Hydraulic ATAC Fan	1672948	27	D-6
Valve Sp. - Solenoid Hydraulic (Steer / Fan)	2795530	30	D-3
Brake - Hold and Suspension Circuits			
Accumulator Sp. - Brake (Change) (Solenoid)	2214255	31	F-11
Accumulator Sp. - Brake (Change) (Coil Start)	2214244	31	F-11
Accumulator Sp. - Brake (Change) (Coil Start)	3484936	32	B-11
Accumulator Sp. - Brake (Change)	1524953	33	F-9
Brake Sp. - Parking	1524953	34	F-9
Brake Sp. - Service (L)	2174209	35	E-8
Brake Sp. - Service (R)	2174209	36	E-14
Brake Sp. - Service (R)	2174209	37	F-8
Brake Sp. - Service (L)	2174209	38	F-14
Brake Sp. - Service Valve	1833073	39	F-12
Core Oil - Cool	1833073	40	D-13
Control Sp. - Brake	2511719	41	A-10
Control Sp. - Suspension (LH)	2582758	42	A-10
Control Sp. - Suspension (RH)	2582758	43	A-10
Control Sp. - Tagplate	1877329	44	A-8
Manifold - Rear Service Brake Control	3484936	45	D-9
Manifold - Rear Service Brake Control	3484936	46	D-9
Manifold - Control (Differential - Lock / Eject)	3074963	47	E-11
Screen - Control Manifold	1652999	48	E-10
Valve Sp. - Check (Brake Charging)	2534635	49	E-11
Valve Sp. - Pressure Reducing (Brake Accumulator)	2534635	50	C-5
Valve Sp. - Pressure Reducing (Differential Lock)	3024234	51	E-11
Valve Sp. - Pressure Reducing (Eject)	1570000	52	C-14
Valve Sp. - Eject	1570000	53	C-14
Valve Sp. - Eject	1570000	54	C-13
Valve Sp. - Pressure (Brake Oil)	3484936	55	E-10
Valve Sp. - Pressure (Brake Oil)	3484936	56	F-9
Valve Sp. - Temperature (Steer / Fan Tank Hydraulic Oil)	2532973	57	A-14
Switch Sp. - Pressure (Rear Br. Pass. (Steer / Fan))	2532973	58	B-13
Switch Sp. - Temperature (Front Brake)	1544511	59	D-13
Valve Sp. - Temperature (Steer / Fan)	1544511	60	B-9
Valve Sp. - Temperature (Steer / Fan)	3254633	61	A-12
Tank Sp. - Hydraulic Oil (Steer / Fan)	1474762	62	A-13
Body - Core Valve (Steer / Eject Tank)	1577011	63	B-13
Breather - Brake / Eject Tank	1524953	64	B-13
Filter Element As. - Brake / Eject Tank	1524953	65	B-13
Screen - Brake Pump Return	1524953	66	B-13
Screen - Eject Return	1524953	67	B-12
Screen As. - Hydraulic Oil (Eject Tank)	1524953	68	B-12
Valve - Brake / Eject Tank	1524953	69	B-12
Valve - Brake / Eject Tank	1524953	70	B-12
Top Location Pressure and Sampling			
Tap Number	Description	Schematic Location	
AA	Eject / Eject Supply Pressure	C-2	
BB	Secondary Steering Pump Pressure	E-5	
CC	Front Axle Brake Pressure	E-13	
DD	Charger / Water Body Heat Prod Pressure	E-13	
EE	Differential Hydraulic Accumulator Charge Pressure	H-3	
FF	Steering Pump / Steer Pressure	D-4	
GG	Steering Pump / Steer Pressure	C-8	
HH	Fan / Fan Pressure	F-2	
II	Fan / Fan Pressure	E-12	
JJ	ATAC Fan / Fan Pressure	D-3	
KK	ATAC Fan / Fan Pressure	D-1	
LL	ATAC Fan / Fan Pressure	E-2	
MM	ATAC Fan / Fan Pressure	B-3	
NN	ATAC Fan / Fan Pressure	C-8	
OO	ATAC Fan / Fan Pressure	C-3	
PP	ATAC Fan / Fan Pressure	D-3	
QQ	ATAC Fan / Fan Pressure	D-3	
RR	ATAC Fan / Fan Pressure	D-3	
SS	ATAC Fan / Fan Pressure	D-3	
TT	ATAC Fan / Fan Pressure	D-3	
UU	ATAC Fan / Fan Pressure	D-3	
VV	ATAC Fan / Fan Pressure	D-3	
WW	ATAC Fan / Fan Pressure	D-3	
XX	ATAC Fan / Fan Pressure	D-3	
YY	ATAC Fan / Fan Pressure	D-3	
ZZ	ATAC Fan / Fan Pressure	D-3	

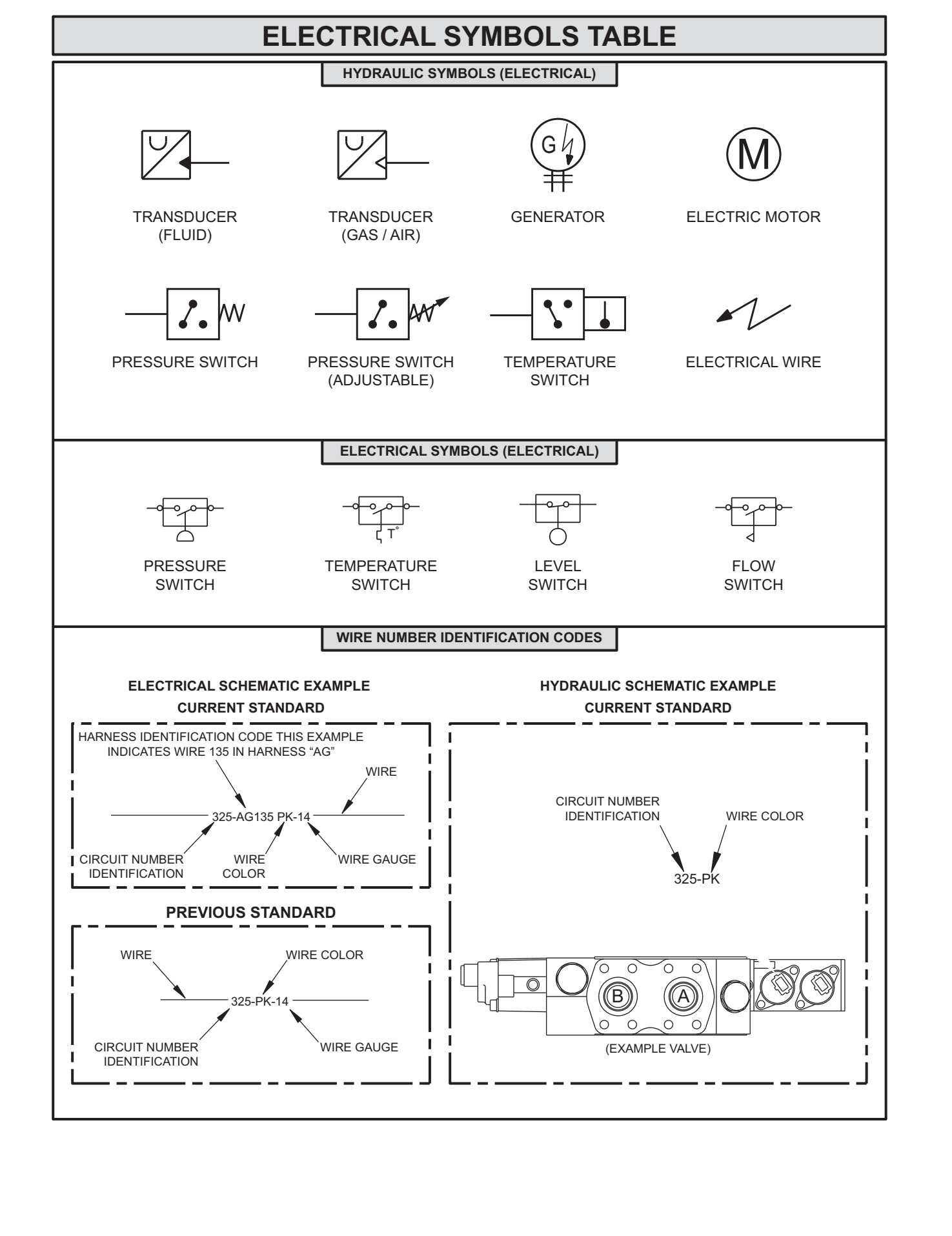
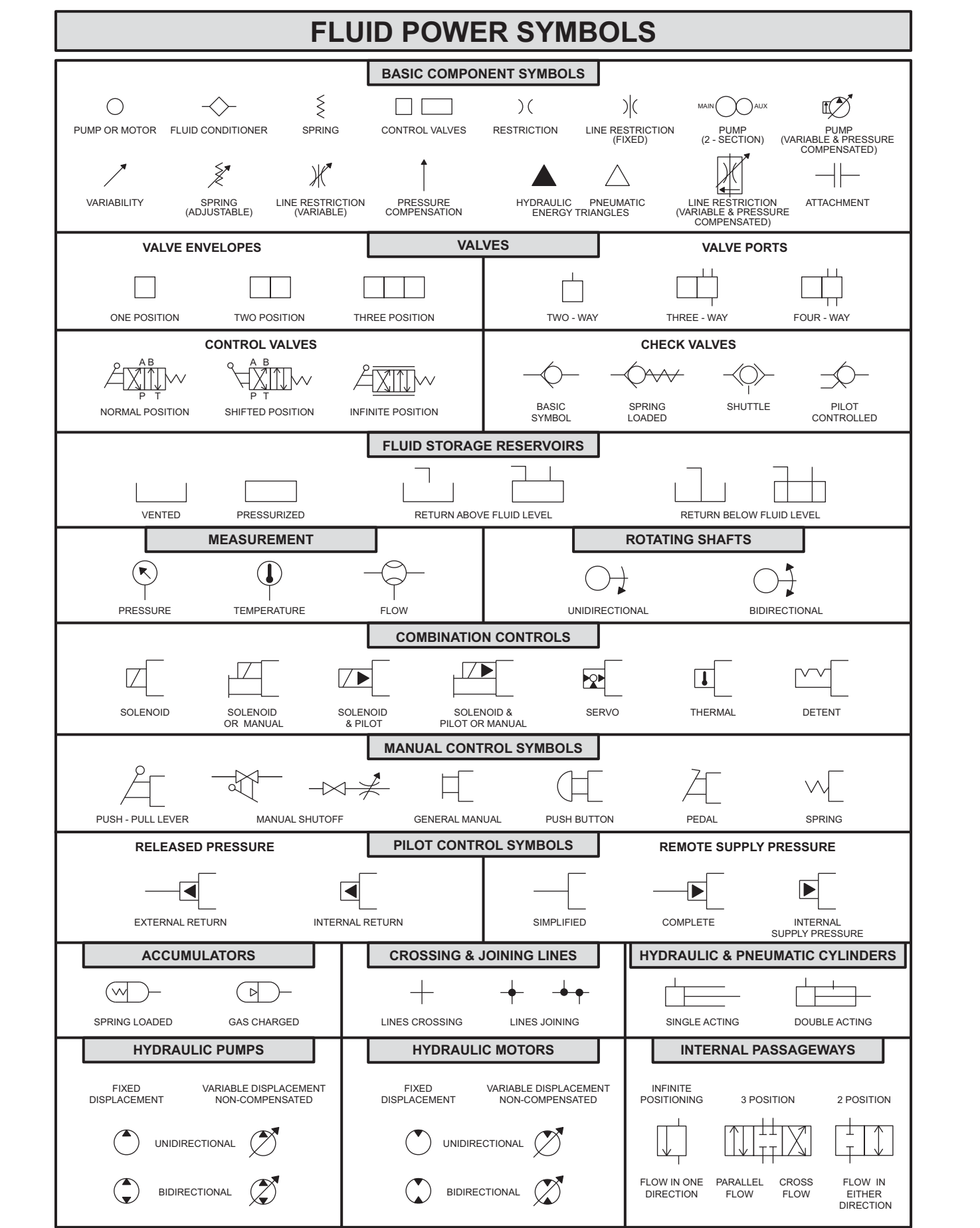
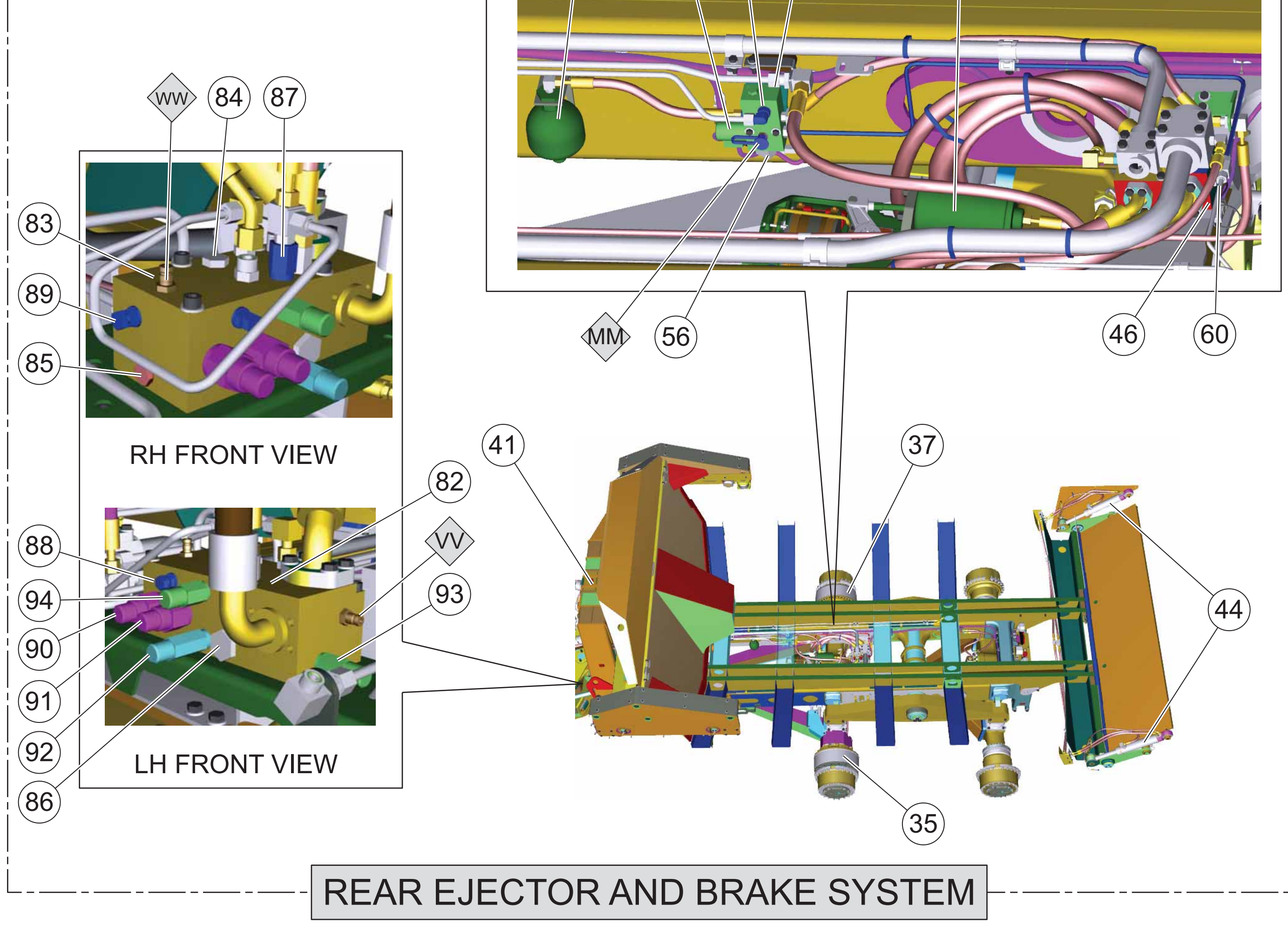
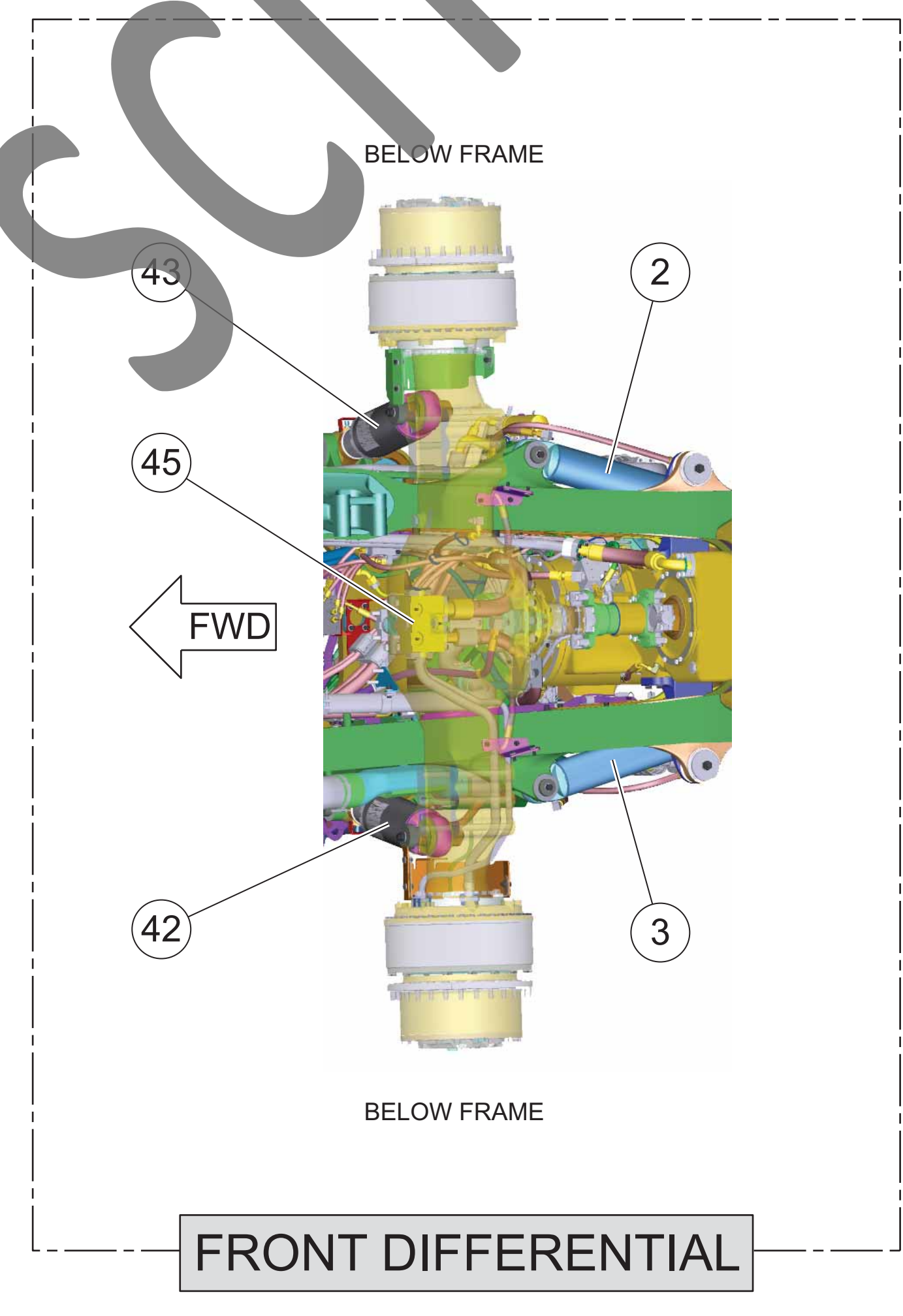
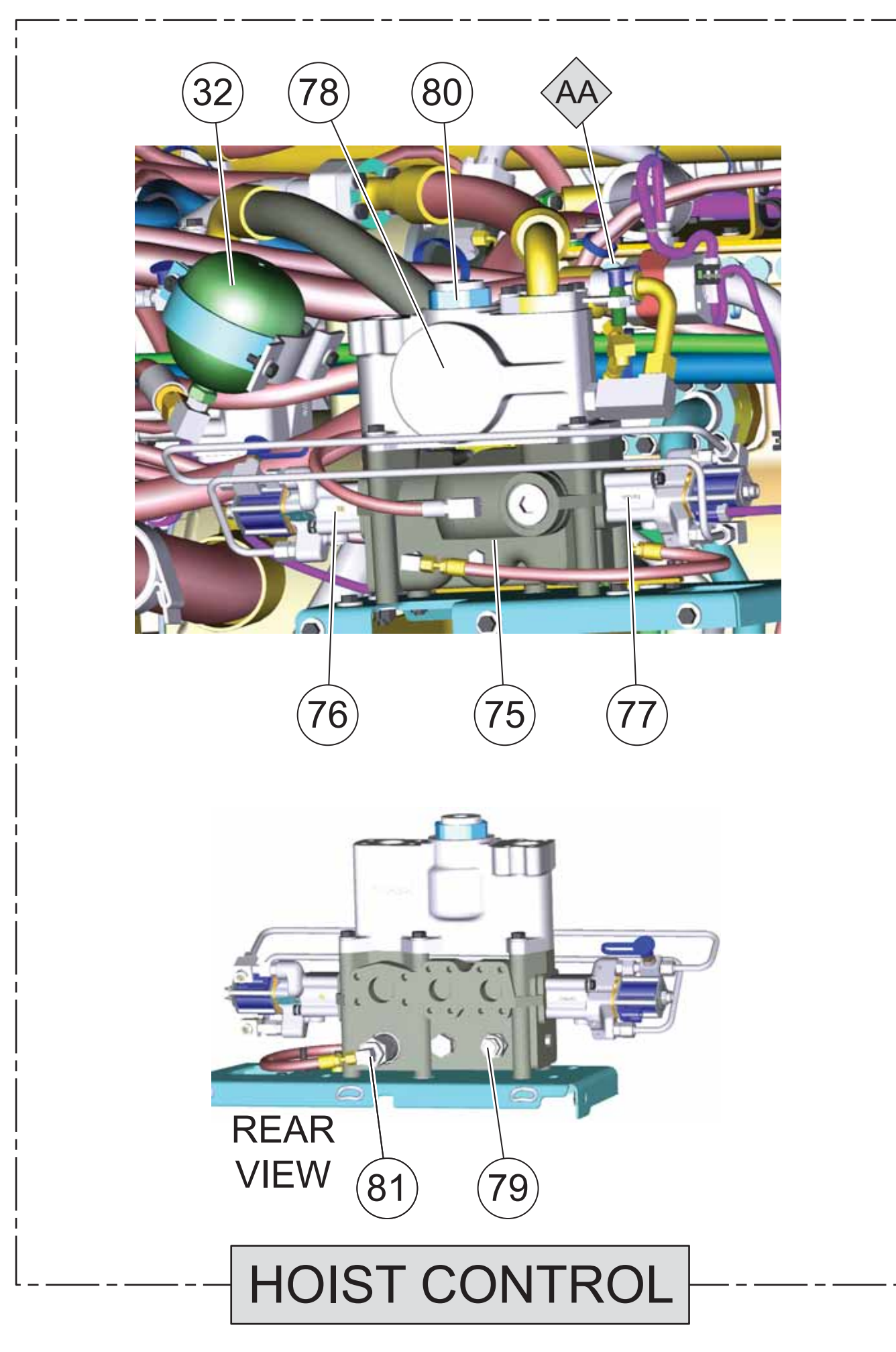
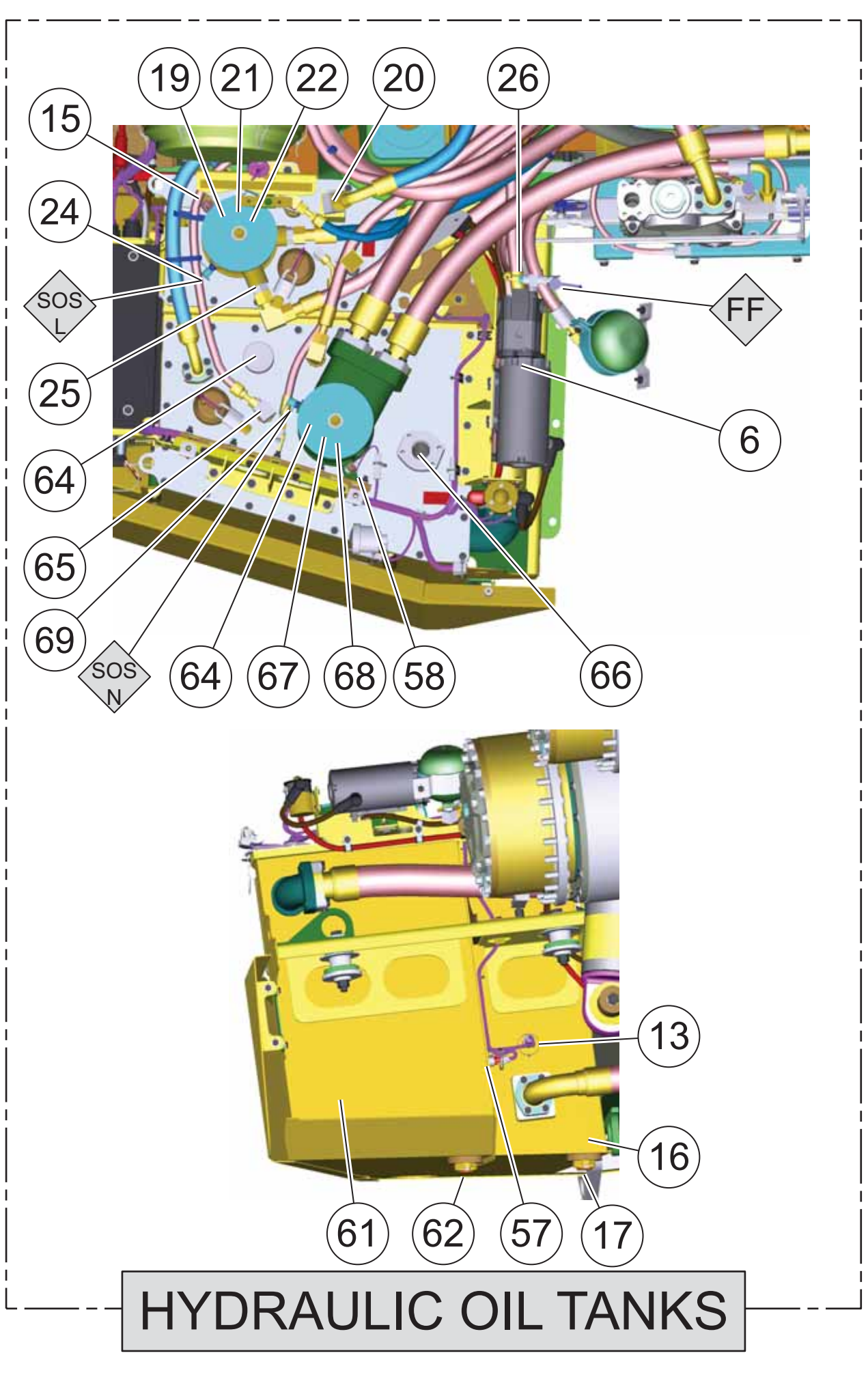
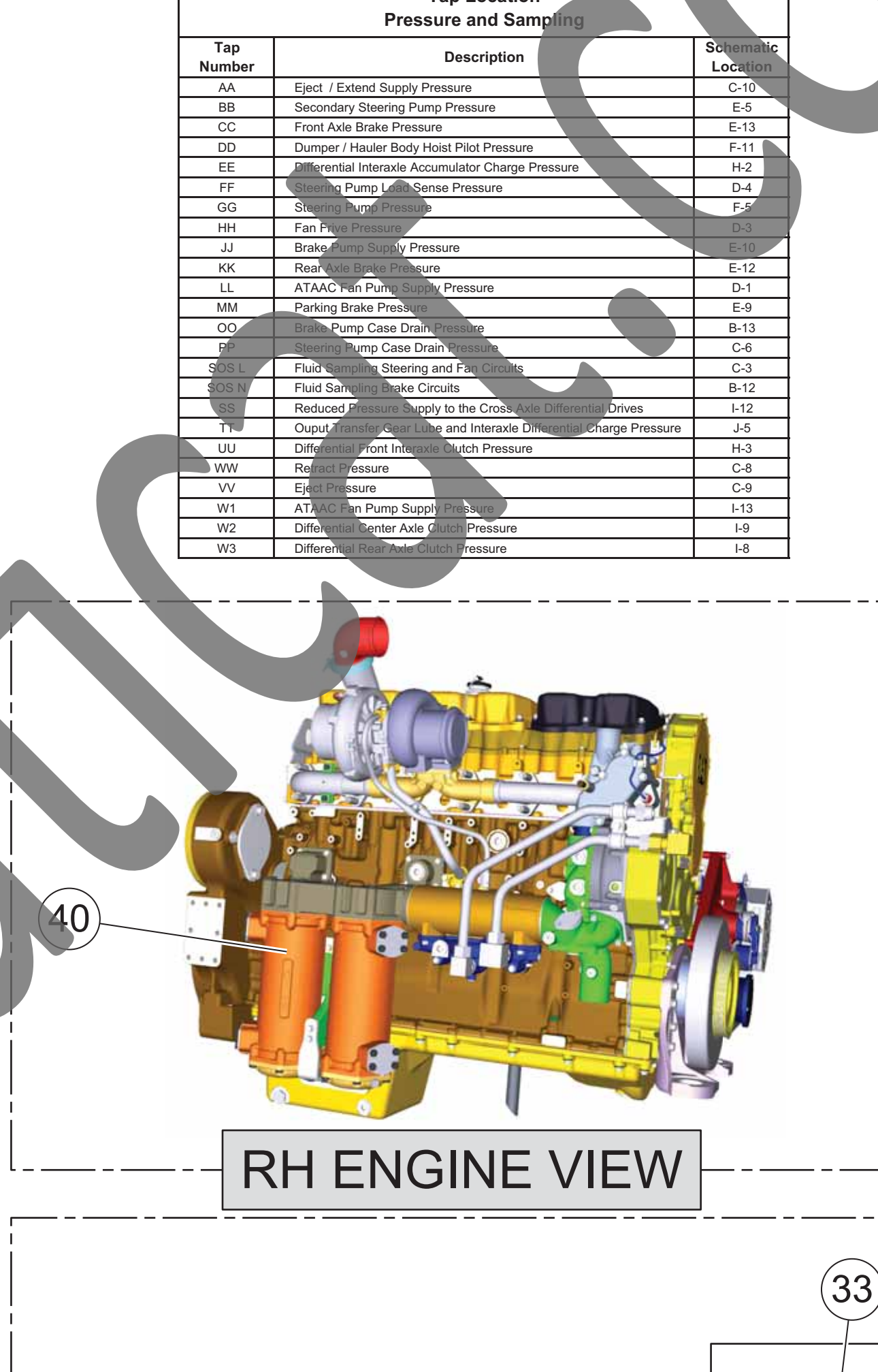
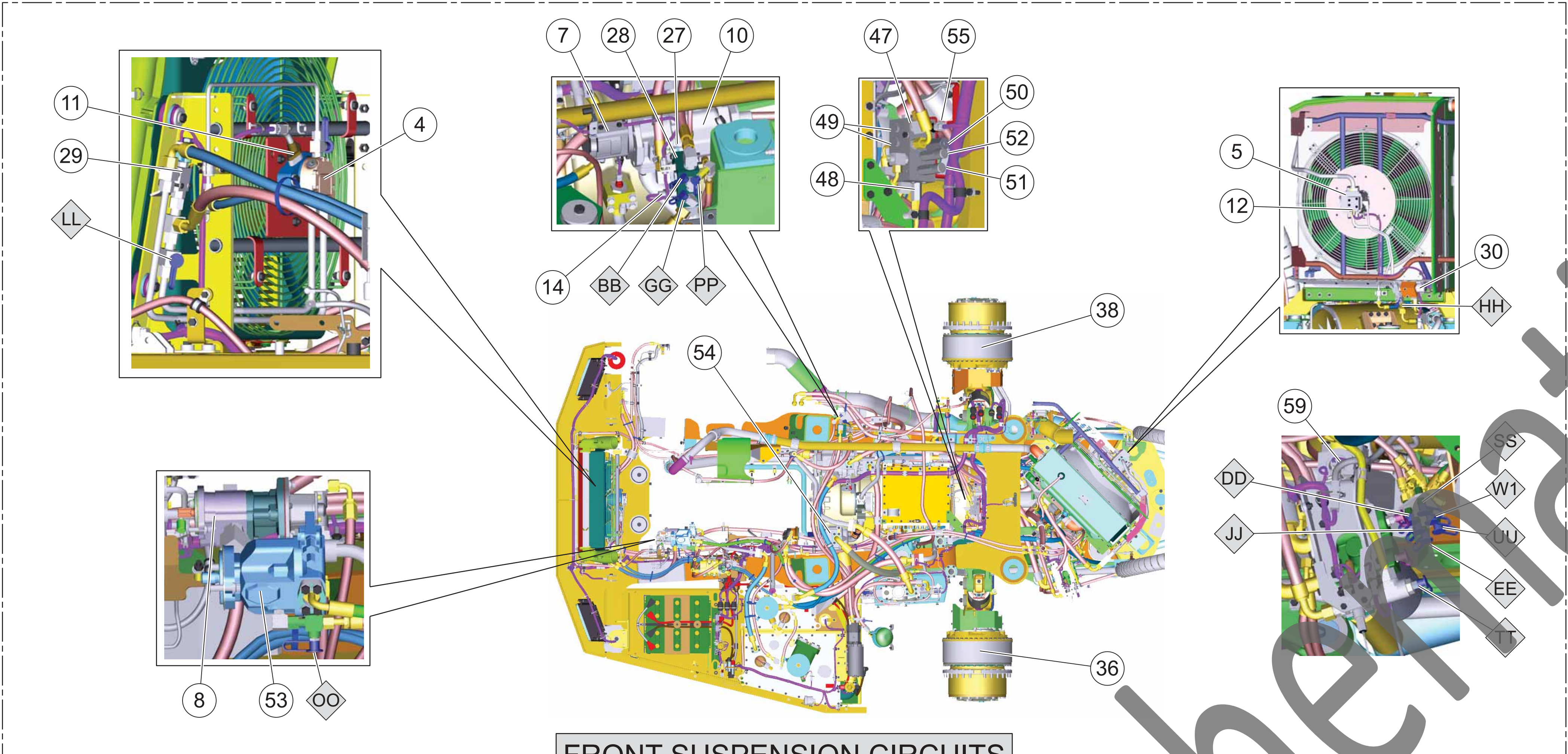

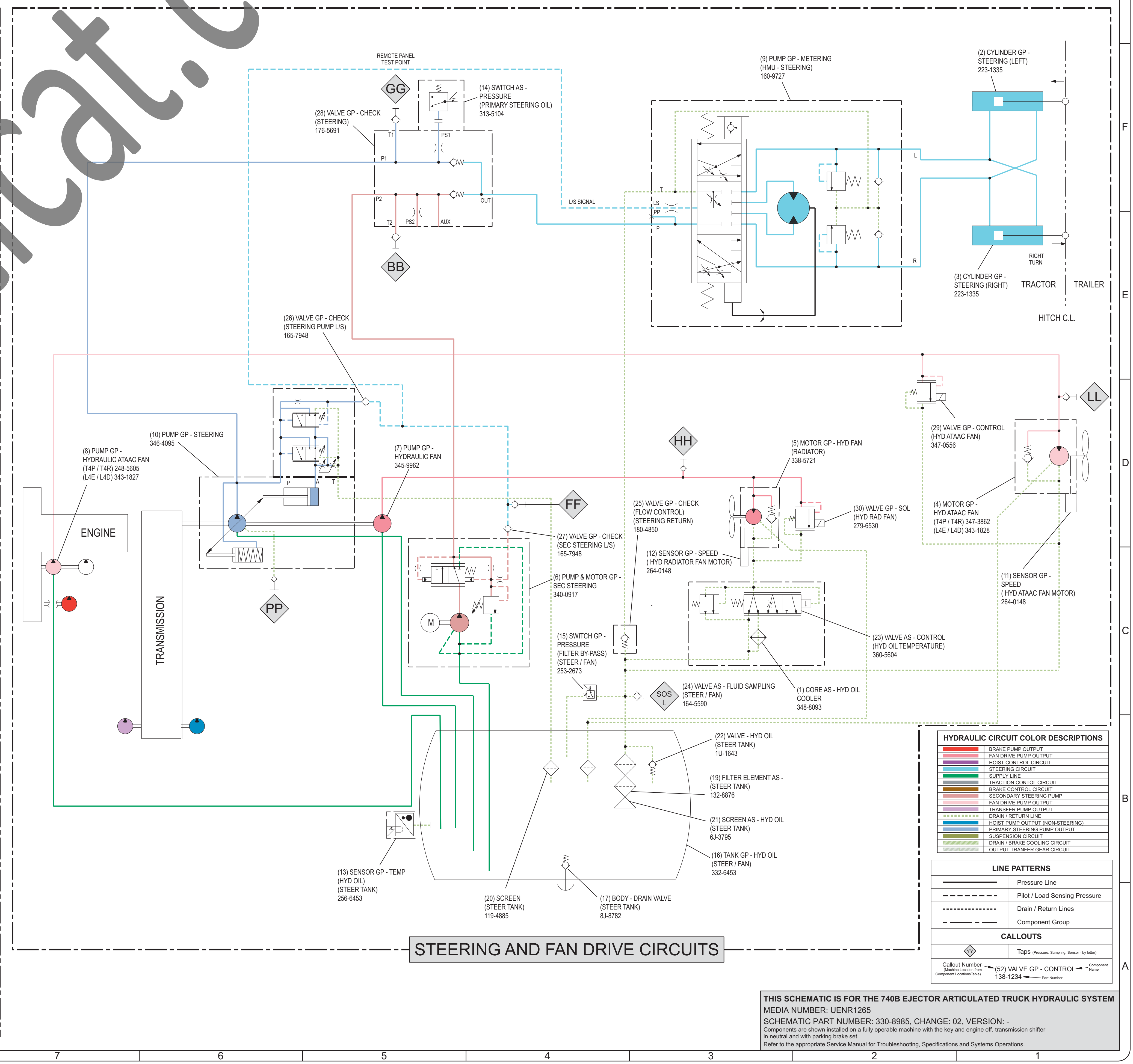
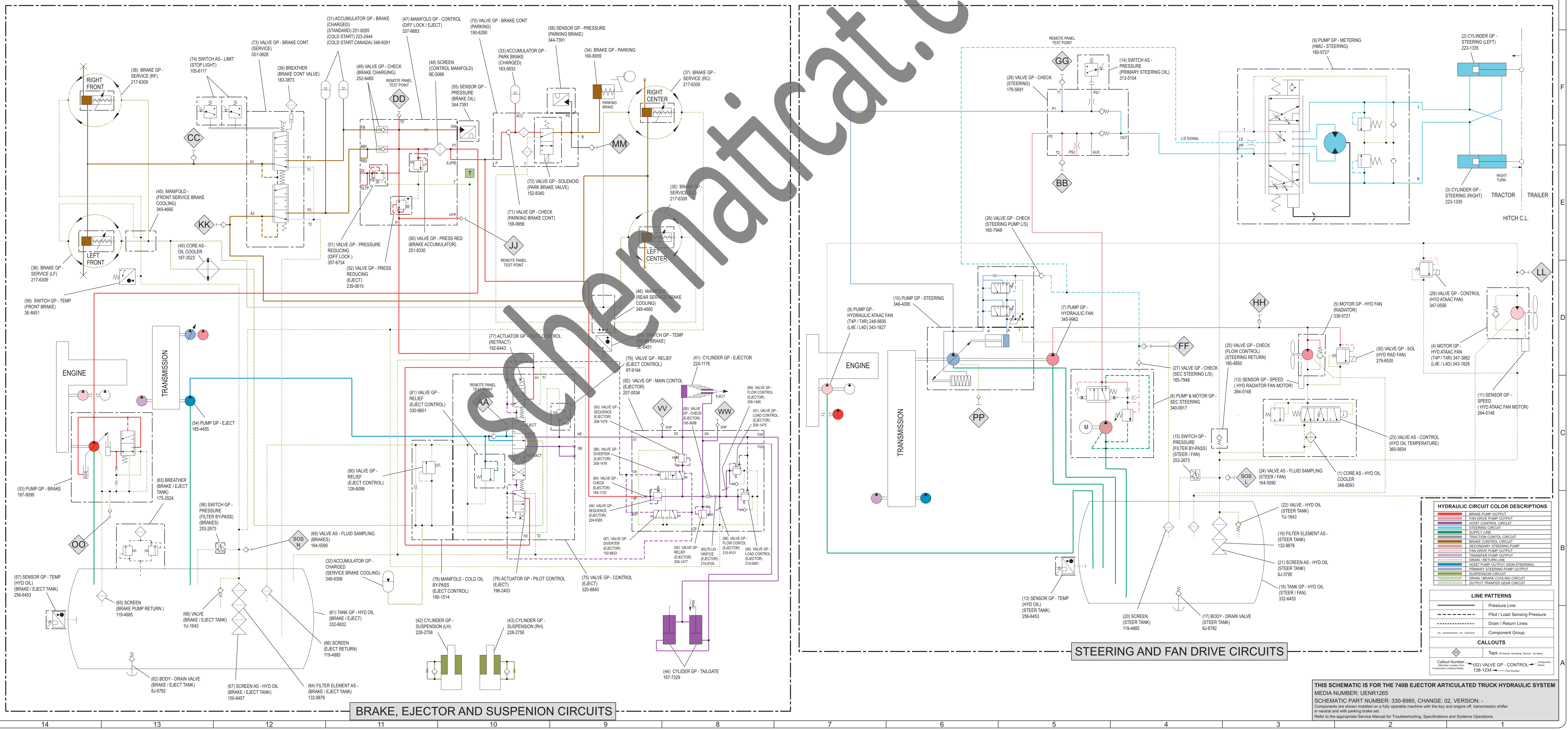
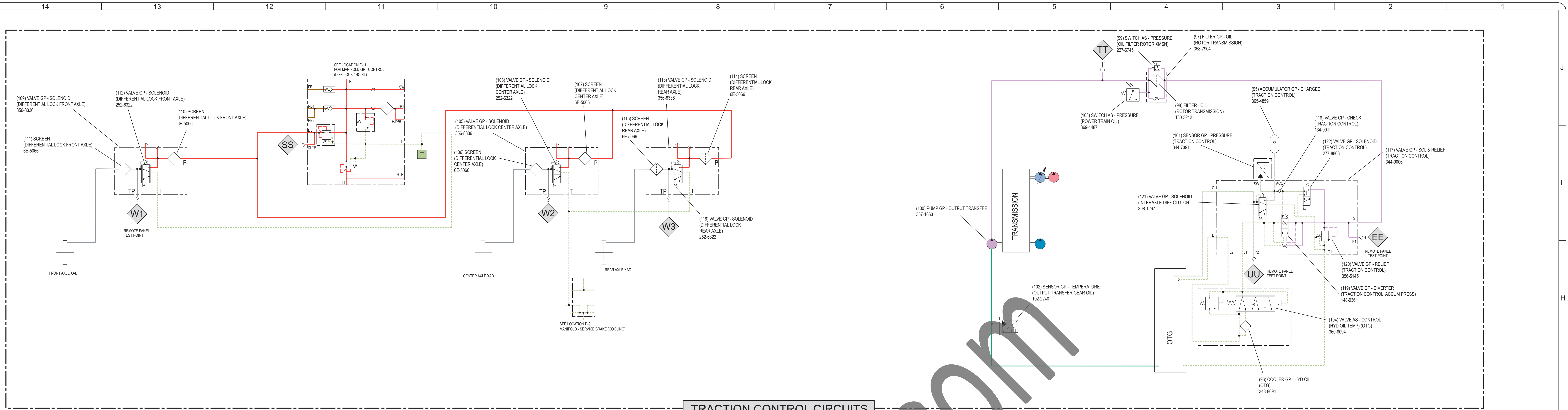

THIS SCHEMATIC IS FOR THE 740B EJECTOR ARTICULATED TRUCK HYDRAULIC SYSTEM
 MEDIA NUMBER: UENR1265
 SCHEMATIC PART NUMBER: 330-8985, CHANGE: 02, VERSION: -
 Components are shown installed on a fully operational machine with the key and except of transmission shift
 in neutral and with parking brake set.
 Refer to the appropriate Service Manual for Troubleshooting, Specifications and Systems Operators.