

EUI Electronic Systems

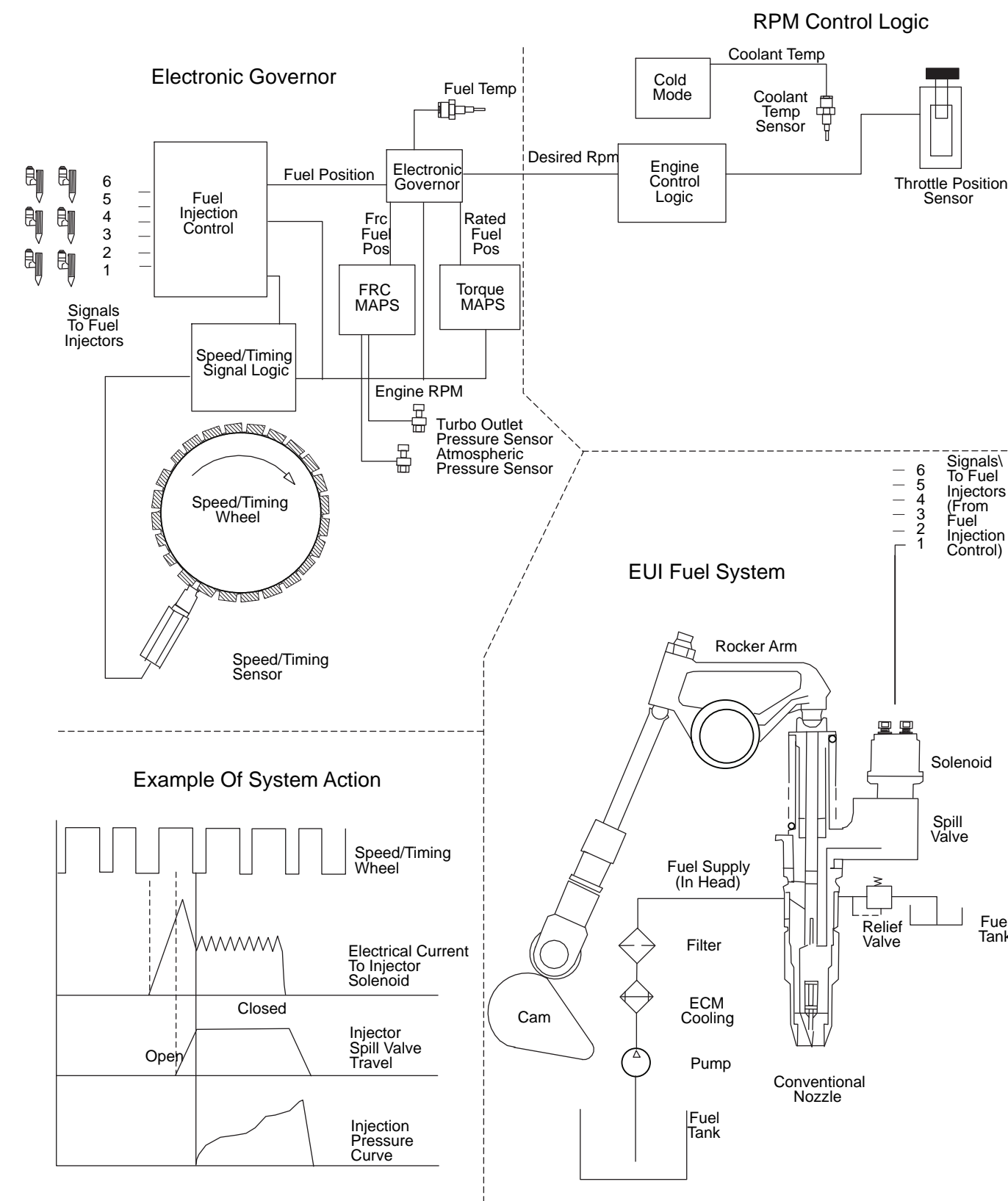

D74036

© 1996 Caterpillar
All Rights Reserved

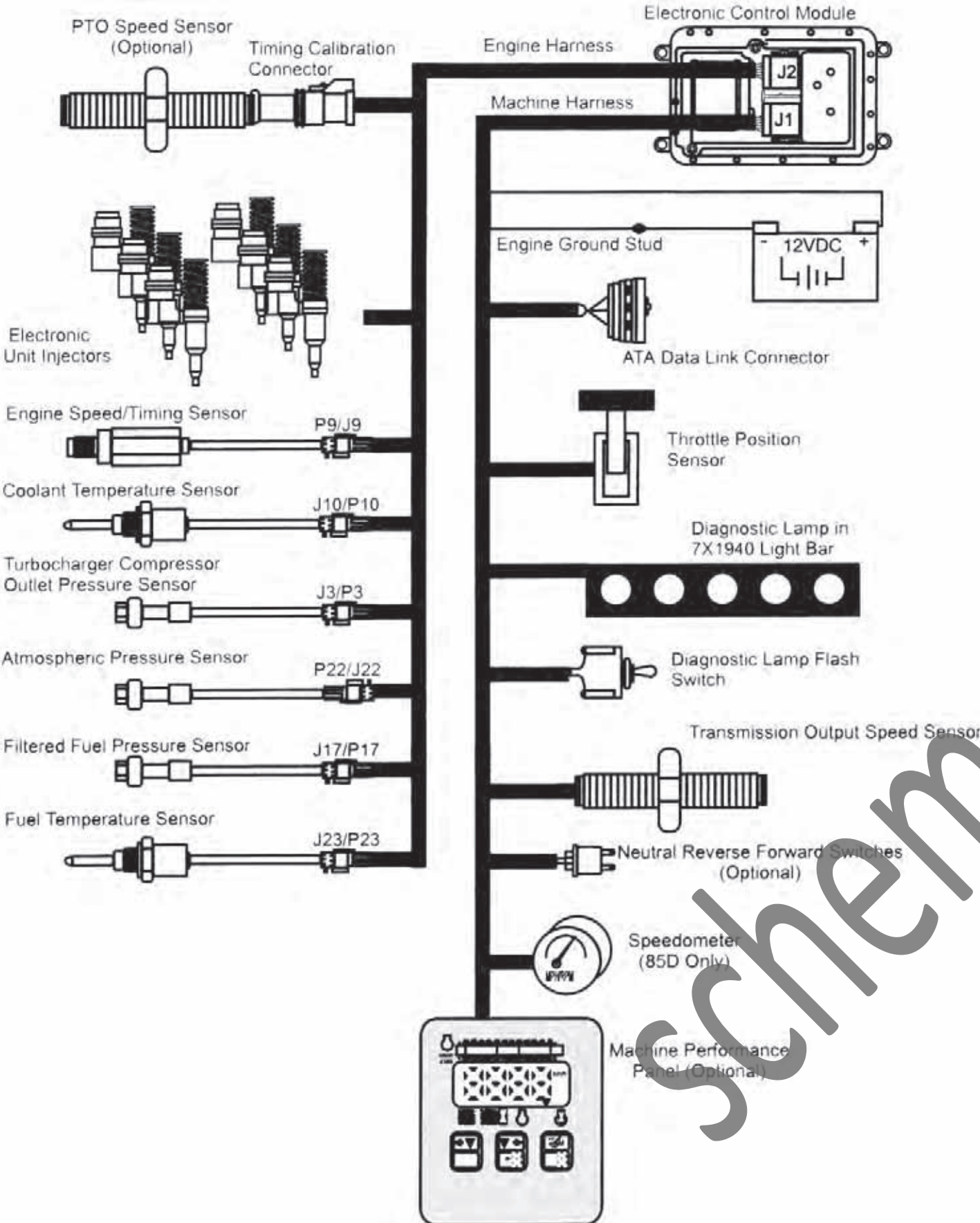

Printed in U.S.A.

CATERPILLAR®

Schematic

3176C And 3196 Engines For Caterpillar Built Machines

6AR1-787
7ZR1-545

For Use In Challenger 75D and 85D Ag Tractors

REN1241
September 1996

Sensor and Connector Locations

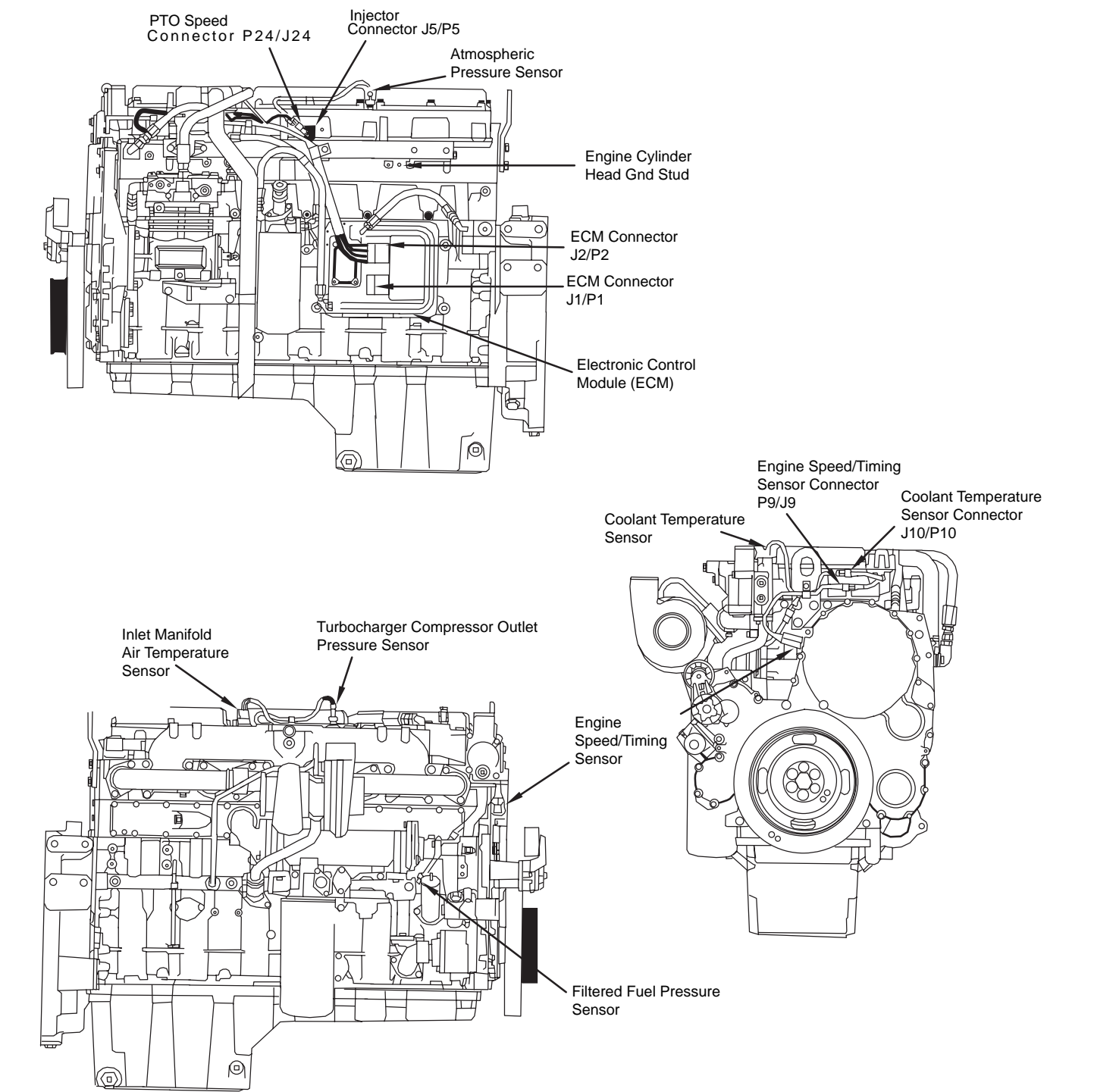

D72552

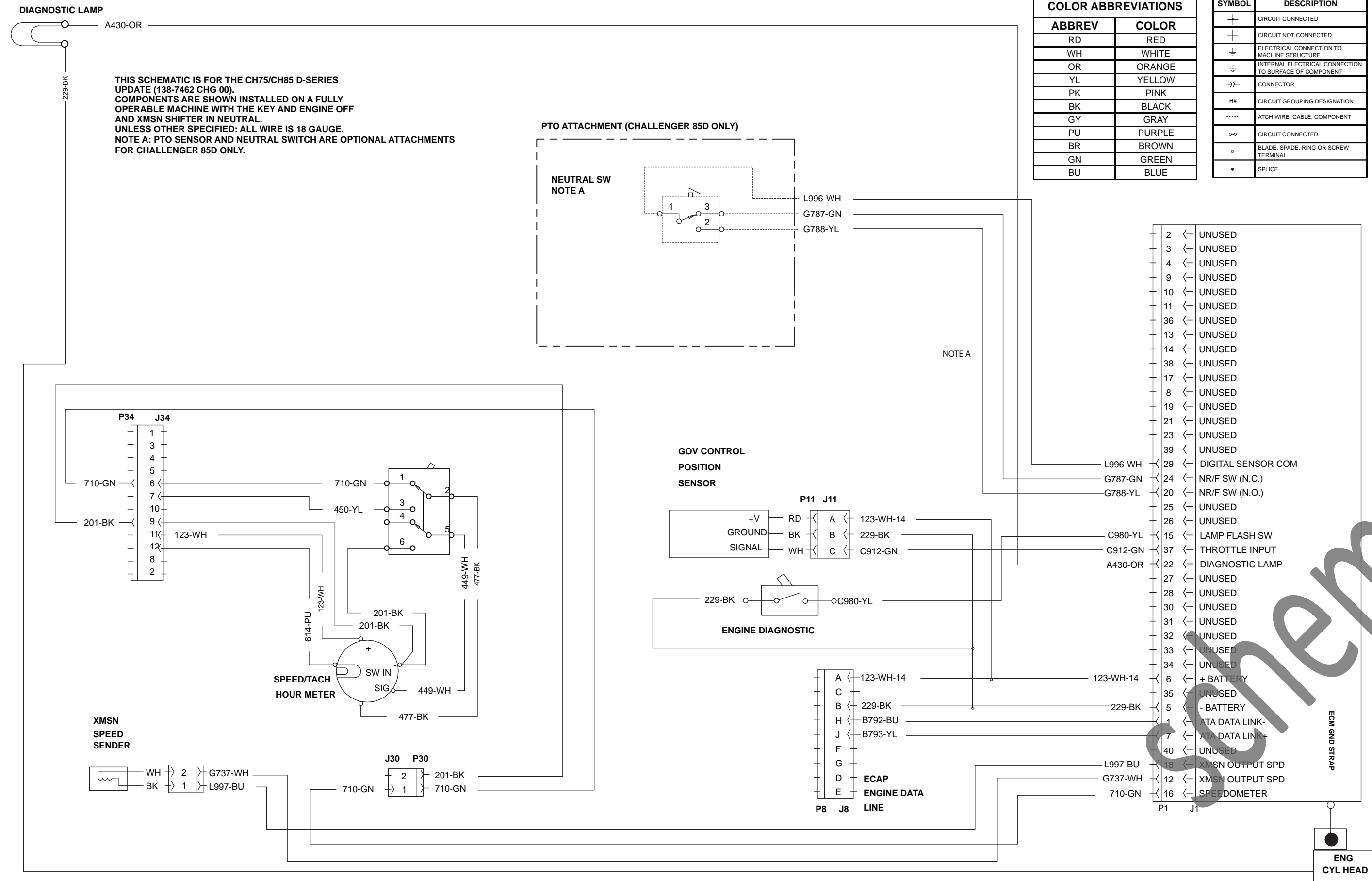

D74284

THIS SCHEMATIC IS FOR THE CH75/CH85 D-SERIES UPDATE (138-7462 CHG 00).

COMPONENTS ARE SHOWN INSTALLED ON A FULLY OPERABLE MACHINE WITH THE KEY AND ENGINE OFF AND XMSN SHIFTER IN NEUTRAL.

UNLESS OTHERWISE SPECIFIED, ALL WIRE IS 18 GAUGE.

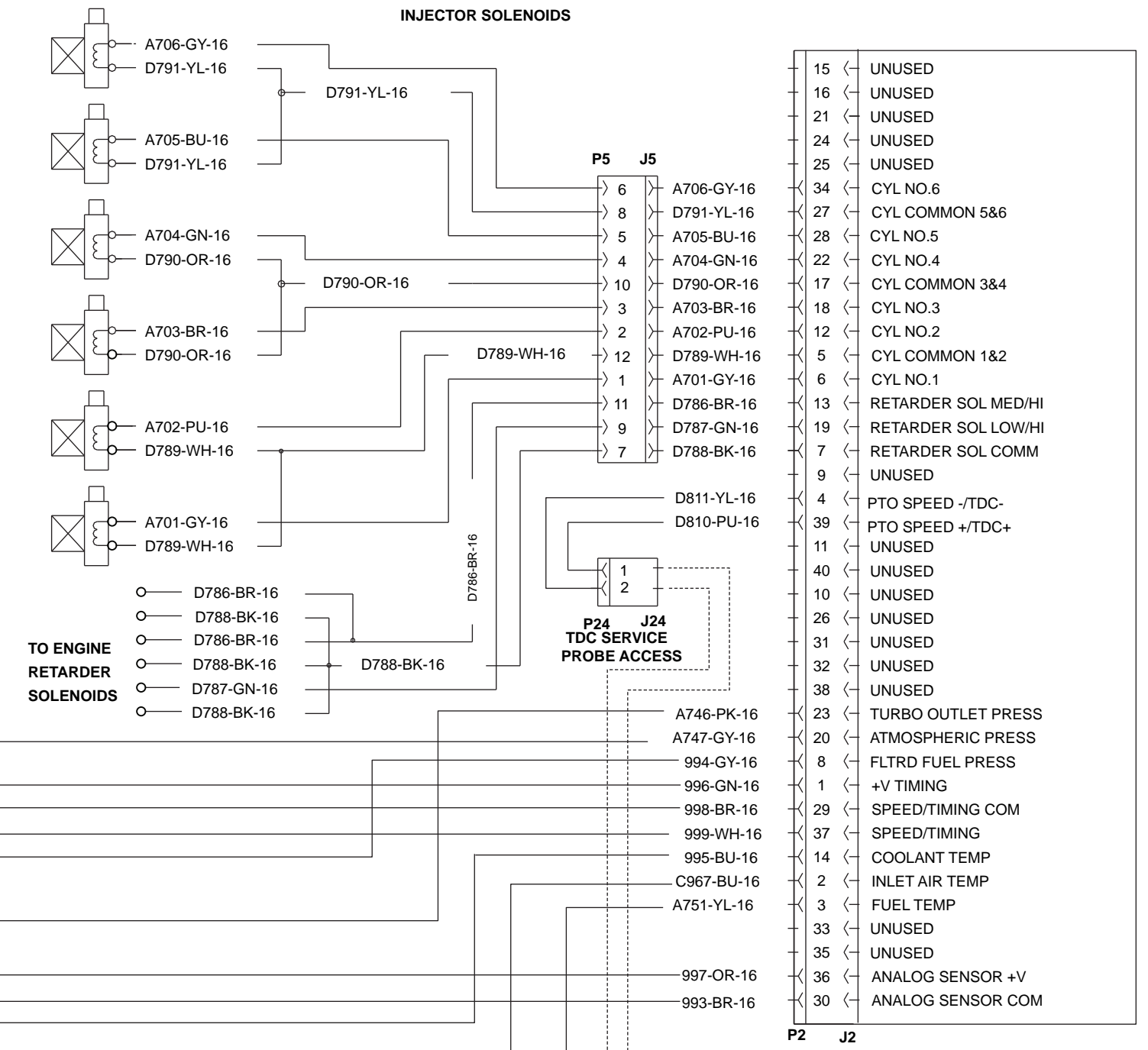
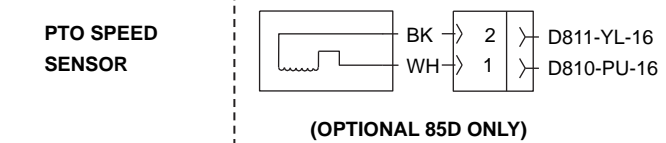
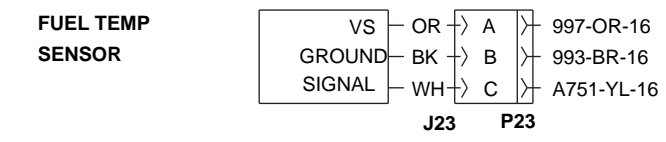
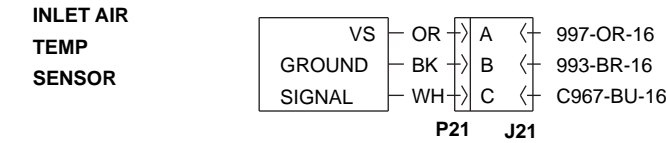
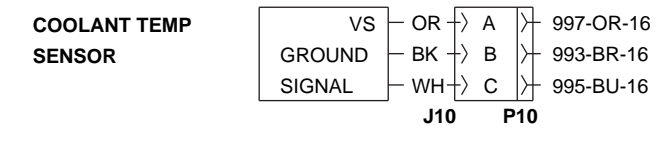
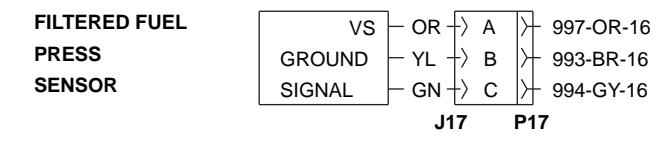
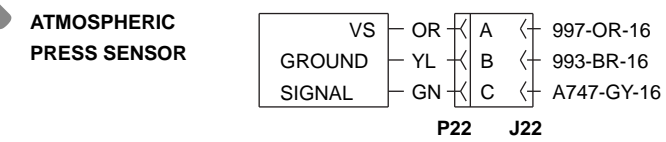
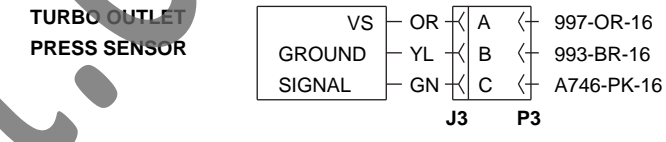
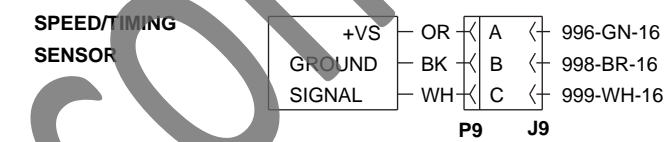

D74285