

Related Electrical Service Manuals		
Title	Form Number	Form Number
Alternator	238-7663	SEN4130
Electric Starting Motor 1	237-1962	SEN9360
VIMS/Payload System		REN8261
Chassis Control System		REN8342
Engine Control System		SEN9832

Component Identifiers (CID) <sup>1</sup> Module Identifier (MID) <sup>2</sup> Chassis Control System (MID No. 087)		
CID	Component	
0041	8 VDC Sensor Power Supply	
0066	Fuel Level Sensor	
0144	Backup Alarm Relay	
0168	Electrical System Voltage	
0177	Transmission Oil Temperature Sensor	
0190	Engine Speed Sensor	
0379	Autolube Pressure Sensor	
0420	Secondary Steering Relay	
0444	Starter Motor Relay	
0533	Brake ECM	
0555	Transmission Output Speed Sensor 1	
0558	Autolube Relay	
0590	Engine ECM	
0637	Backup Alarm	
0669	Transmission Input Speed Sensor	
0673	Transmission Gear Lever Sensor	
0702	Transmission Lockup Clutch Solenoid	
0716	Transmission Solenoid	
0724	Host Raise Solenoid	
0725	Host Lower Solenoid	
0772	Host Lower Switch	
0826	Torque Converter Oil Temperature Sensor	
0967	Machine Application	
1245	Accumulator Bypass Relay	
1326	BCM Location Code	
1401	Transmission Solenoid 1	
1402	Transmission Solenoid 2	
1403	Transmission Solenoid 3	
1404	Transmission Solenoid 4	
1405	Transmission Solenoid 5	
1406	Transmission Solenoid 6	
1407	Transmission Solenoid 7	
1674	Proportional Solenoid Feedback Return 1	
1675	Proportional Solenoid Feedback Return 2	
2177	Primary Steering Shuttle Solenoid	
2448	Graphical Display Module	

Engine Control System (MID No. 036)		
CID	Component	
0001	Cylinder 1 Injector Solenoid	
0002	Cylinder 2 Injector Solenoid	
0003	Cylinder 3 Injector Solenoid	
0004	Cylinder 4 Injector Solenoid	
0005	Cylinder 5 Injector Solenoid	
0006	Cylinder 6 Injector Solenoid	
0007	Cylinder 7 Injector Solenoid	
0008	Cylinder 8 Injector Solenoid	
0009	Cylinder 9 Injector Solenoid	
0010	Cylinder 10 Injector Solenoid	
0011	Cylinder 11 Injector Solenoid	
0012	Cylinder 12 Injector Solenoid	
0041	8 Volt DC Supply Short	
0091	Throttle Position Signal	
0094	Fuel Pressure	
0100	Engine Oil Pressure	
0110	Engine Oil Pressure Sensor	
0168	System Voltage	
0172	Intake Manifold Air Temperature	
0174	Fuel Temperature	
0190	Engine Speed Signal	
0253	Personality Module	
0261	Engine Timing	
0262	5 Volt Sensor DC Power Supply	
0267	Incorrect Engine Shutdown Switch	
0269	System Parameters	
0274	Atmospheric Pressure	
0291	Engine Cooling Fan Solenoid	
0342	Secondary Engine Speed	
0353	Brake Control	
0544	Engine Cooling Fan Speed Sensor	
0569	Oil Injection Solenoid	
1273	Chassis Control Module	
1589	Turbo Inlet Air Pressure Sensor	
1785	Intake Manifold Pressure Sensor	
1795	Turbo #2 Outlet Pressure Sensor	
1796	Intake Manifold #2 Air Temperature Sensor	
2211	Engine Oil Renewal System Actuation Solenoid	
2417	ETHER Injection Control Module	
2533	Compression Brake Low/High Solenoid #1 Low Current	
2534	Compression Brake Low/High Solenoid #2 High Current	
2535	Compression Brake Medium/High Solenoid #1 Low Current	
2536	Compression Brake Medium/High Solenoid #2 High Current	

### TPMS/VIMS Control System

267	Resends Shutdown Input
533	Brake Control
560	Engine Control Module
824	TPMS Lamp #1 (GREEN)
825	TPMS Lamp #2 (RED)
838	Left Front Strut Pressure Sensor
839	Right Front Strut Pressure Sensor
840	Left Rear Strut Pressure Sensor
841	Right Rear Strut Pressure Sensor
890	Telemetry Data Link
1272	Chassis Control Module
2183	Payload Monitoring System
2448	Graphical Display Module

<sup>1</sup> The CID is a diagnostic code that indicates which circuit is faulty.  
<sup>2</sup> The MID is a diagnostic code that indicates which electronic control module diagnosed the fault.

Failure Mode Identifiers (FMI) <sup>1</sup>	
FMI No.	Failure Description
0	Data valid but above normal operational range.
1	Data valid but below normal operational range.
2	Data erratic, intermittent, or incorrect.
3	Voltage above normal or shorted high.
4	Voltage below normal or shorted low.
5	Current above normal or open circuit.
6	Current below normal or ground circuit.
7	Mechanical system not responding properly.
8	Abnormal frequency, pulse width, or period.
9	Abnormal update.
10	Abnormal rate of change.
11	Failure mode not applicable.
12	Bad device or component.
13	Out of calibration.
14	Parameter failures.
15	Parameter failures.
16	Parameter not available.
17	Module not responding.
18	Sensor supply fault.
19	Condition not met.
20	Parameter failures.

<sup>1</sup> The FMI is a diagnostic code that indicates what type of failure has occurred.

Connector Location		
Connector Number	Schematic Location	Machine Location
CONN 1	G-14	2
CONN 2	G-14	2
CONN 3	F-14	3
CONN 4	F-14	4
CONN 5	E-14	5
CONN 6	H-13	6
CONN 7	H-13	7
CONN 8	H-13	8
CONN 9	G-11	9
CONN 10	G-11	10
CONN 11	B-10	11
CONN 12	B-10	12
CONN 13	F-8	13
CONN 14	H-14	14
CONN 15	G-9	15
CONN 16	G-9	16
CONN 17	F-9	17
CONN 18	E-9	18
CONN 19	D-9	19
CONN 20	D-9	20
CONN 21	H-14	21
CONN 22	D-4	22
CONN 23	C-5	23
CONN 24	B-5	24
CONN 25	F-2	25
CONN 26	F-2	26
CONN 27	E-2	27

The connectors shown in this chart are for harness to harness connections. Connectors that join a harness to a component are generally located at or near the component. See the Component Location Chart.

Wire Description			Wire Description		
Wire Number	Wire Color	Description	Wire Number	Wire Color	Description
101	RD	Transmission Shift	725	GN	XMSN Gear Code 5
102	RD	Host Lamp	726	BU	XMSN Gear Code 6
105	RD	Stop Lamps	727	GN	Stop Steering Motor Relay
107	RD	Host Lower Switch	728	BU	Starter Pressure Switch
108	BU	Air Slew	767	WH	Wheel Speed Sensor
109	RD	All Output (at Term.)	769	BU	Wheel Speed Sensor Lath
112	PJ	Main Power Rly Output	770	PJ	Wheel Speed Pickup (Right)
113	OR	Opt Mon Panel VMS is Switched	771	PJ	AET A Service Brake Switch
114	RD	BCM Location Code	772	PJ	AET A Release Switch
115	PK	Compression Brake Switch	773	GY	AET A Servo Valve
117	YL	LVX Capax Lighter	774	TE	AET A Solenoid Lath
118	GY	Front Wiper	775	TE	AET A Solenoid (Right)
121	YL	Back Alarm To Lamp	A700	OR	Digital Sensor Power (BU)
124	GN	WVAC Converter Panel	E716	PK	Body Lower Solenoid
126	RD	XMSN Clut	F750	PJ	Body Position Sensor Signal
129	BU	Custom Light #2	E790	PK	Start Relay to Chassis Cont (GND)
136	GN	Body Bld	F792	GN	Throttle Position Sensor
138	GN	Auto Lube	F710	BR	Engine Oil Solenoid
149	BU	High Speed Relay	F714	PK	Right Turbo Inlet Pressure
141	PK	Heated Mirror Seat	F715	PJ	Ground Level Shutdown Switch (incl)
150	RD	Bar (A)	F716	WH	Ground Level Shutdown Switch (incl)
165	YL	Start Aid	F717	YL	Throttle Lock Switch
170	RD	Payload	G704	YL	Body Breeze Solenoid
175	PK	Aux Clt	G705	GN	Body Lower Solenoid
177	RD	Main Btr	G731	GY	Eng #1 - Secondary Service Brake Sol
178	RD	Aux Clt	J725	GN	Crank Lockout Switch to Machine ECM
194	GN	Crank Machine Lockout	J726	GN	Machine ECM to Crank Lockout LCP
200	BR	Main Chassis	J727	YL	Swing Arm Disables SOL
201	BR	Adixon Alarm	J764	BR	Switch/Sensor Return #1
202	BR	Adixon Alarm	J765	BU	Switch/Sensor Return #2
203	BR	Adixon Alarm	K737	BR	Brake Solenoid Cylinder 2, 10, 12
219	BR	XMSN B Code 0	K738	GN	Brake Solenoid Cylinder 6, 8
229	BR	Bar (I)	K739	BU	Engine Retarder Solenoid Common
231	BR	Backup Monitor - System Ground	K742	OR	Top Gear Switch Logic
251	BR	Backup Monitor - System Ground	K748	OR	Secondary Service Brake Relay
<b>Brake Machine Circuits</b>					
304	WH	Starter Relay No. 1 Output	M728	WH	Fuelbus Diverter Relay in SOL
305	GN	Starter Relay Can Not Start Sw	N707	PJ	Engine Digital Sensor Return
307	OR	Key Sw To Neutral Start Sw Or Vms	R747	GY	Atmospheric Pressure Sensor
308	YL	Main Power Relay Coil	T725	WH	Fuel Filter Switch
317	YL	Start Aid Relay To Start Aid Solenoid	T749	YL	Chassis ECM to Spec Brake Pressure Sw
320	OR	Host Relay Coil Switch	T750	BR	Chassis ECM to Spec Brake Pressure Sw
321	BR	Backup Alarm Lamp Travel Alarm	T782	OR	Lockout/Service Mode Switch
322	GY	Warning Horn (Forward)	T783	PJ	Oil Evac Hose Sw To EVAC (Enabled)
326	RD	Oil Evac Hose Sw To EVAC (Connected)	T784	GN	Chassis ECM to Spec Brake Pressure Sw
327	PK	Shutdown Solenoid	Y787	WH	Can Data Link (I) - Implements
329	YL	Fuel Pump To Switch	Y788	GY	Can Data Link (I) - Implements
365	YL	Fuel Pump Relay to Switch	801	PK	Auto Lube Connector
366	YL	Fuel Pump Relay to Switch	808	GY	Payload Monitor Body Sensor
403	GN	Secondary Steering (R) Term.	869	YL	Payload Monitor Left Front Sensor
410	WH	Action Alarm	892	PK	Payload Monitor Brake Sensor
425	BR	Opt Mon Press Train Oil Filter	893	GN	Payload Monitor Right Front Sensor
432	PK	Opt Mon Brake Pressure	892	BR	VMS Start Mod Right (I)
444	BU	Converter/Retarder Oil Temp Gauge	893	GN	VMS Start Mod Right (I)
446	PJ	Brake Oil Temp Sensor	G528	WH	AdEM II Pressure Sensor #1
447	PK	Fuel Level Gauge	G529	GN	AdEM II Pressure Sensor #2
C436	BU	Differential Filter Press Switch	G533	PK	AdEM II Engine Temp Sensor Common
C471	GN	Relay Control To Indicator Lamp	G534	PJ	AdEM II Cooling Fan Speed #1
F418	GN	VMS RS232 Port 2 Trans.	G535	OR	AdEM II Cooling Fan Speed #2
F419	YL	VMS RS232 Port 2 Receive	G556	WH	TDC Probe #1
F421	YL	Fuel Temp	G557	WH	TDC Probe #2
H420	PJ	Secondary Steering Indicator	G577	YL	Coolant Fan Solenoid
<b>Accessory Circuits</b>					
500	BR	Wiper - Front (Park)	H802	GY	Proportional Driver Return (1-4)
501	GN	Wiper - Front (Low)	H803	BU	Proportional Driver Return (8-12)
502	OR	Wiper - Front (High)	806	YL	Auto Retard Off Switch
506	PJ	Washer - Front	J840	WH	TPMS Lamp - Green
508	PJ	Radio Speaker - Left	J841	YL	TPMS Lamp - Red
509	WH	Radio Speaker - Right	J842	YL	TPMS Lamp - Yellow
511	BR	Radio Speaker - Right	A816	PK	Autolube Clut Control
512	GN	Radio Speaker - Right	T858	GY	Injector High Side
513	OR	A/C Compressor Pressure Switch	T859	OR	Injector High Side
515	GY	Blower Motor (High)	T860	OR	Injector High Side
516	GN	Blower Motor (Medium)	921	WH	XMSN SOL Upshift
517	BU	Blower Motor (Low)	922	BR	XMSN SOL Downshift
519	PK	Thermistor To Refrigerant Press. Sw	928	YL	Relay Logic
520	WH	OPR A/C Switch to Thermoast/ Fuse	993	BR	Analog Sensor Common
521	YL	A/C Switch To Refrigerant Switch	994	GY	Oil Pressure (IFB) Sensor
522	WH	A/C Clutch To Thermoast Switch	995	BU	Coolant Temperature
537	GN	Turn Signal Switch To Flasher	997	OR	Analog Sensor Power (+5V)
567	WH	A/C Switch/Jumper	998	BR	Digital Sensor Return
575	YL	Wiper - Aux (Park)	A858	WH	Park Brake Solenoid
576	PK	Wiper - AUX (Low)	C967	BU	Intake Air Temperature
577	PJ	Wiper - AUX (High)	C981	GN	Exhaust Brake
578	BU	Wiper - AUX	C991	PK	Fuel Filter Monitor
590	GY	Wiper Switch To Intermittent Mode	E900	WH	ECPC Trans Output Speed +
591	WH	Intermittent Mode To Wiper Motor	E901	GN	ECPC Trans Output Speed -
592	BU	DC/DC Converter Power Output	E906	OR	ECPC Trans Output Speed 0
A613	RD	DC/DC Converter Memory Output	E907	GY	ECPC Trans Output Speed Q
A524	BR	Temp. Interconnecter Port 2	E963	BR	Engine Speed/Timing
A521	PJ	Heated Mirror	E964	WH	Engine Speed/Timing A+
A522	PK	Heated Mirror	E965	BU	Engine Speed/Timing B-
C547	OR	Lighting Circuits	E966	YL	Engine Speed/Timing B+
602	WH	Dome Lamp	E972	BU	SPI DataLink End
604	OR	Stop Lamp	F975	OR	BK Oil Temp Sensor Supply +
605	YL	Turn Lamp - (Left)	K952	BR	Solenoid Return 3
606	GY	Turn Lamp - (Right)	K955	BR	Auto Retard Off Switch
610	OR	Head Lamp (Basic)	K988	WH	Auto Retard Air Cont Valve
611	PJ	Head Lamp (High)	K992	PJ	Auto Retard Manual Release Switch
612	GY	Backup Lamp	L504	BU	Secondary Brake Solenoid
614	PJ	Park/Dash/Lamp	L912	WH	Engine Speed +
619	GN	Head Lamp Low	L913	OR	Engine Speed -
635	BU	Payload Monitor Red Lamp	M996	PK	Head Lever Position
636	GN	Payload Monitor Green Lamp	M997	PJ	Shift Lever Position
643	GN	Display Intensity Lip	N857	PK	RKD - Common #1
644	OR	Brightness Adjust	N858	OR	RKD - Common #2
675	PJ	Aux Active Lamp	N870	YL	OTIS - Common #1
A611	PJ	AUX Headlamp High	N873	BR	DCD - Common #1
720	PK	Control Circuits	N979	GN	Signal (Ground) - Comm #1
703	BU	XMSN In Br SOL	P910	BR	Secondary Steering Shut Switch Input
704	GY	XMSN Down SOL	R971	YL	Transmission Lube Filter Switch
705	PK	XMSN Release Clutch Solenoid Bases	T957	PJ	Injector 1 Return
706	PK	XMSN Release Clutch Solenoid Bases	T958	YL	Injector 2 Return
708	YL	XMSN Head Switch	T959	BR	Injector 3 Return
721	BR	XMSN Gear Code 1	T960	BU	Injector 4 Return
722	WH				

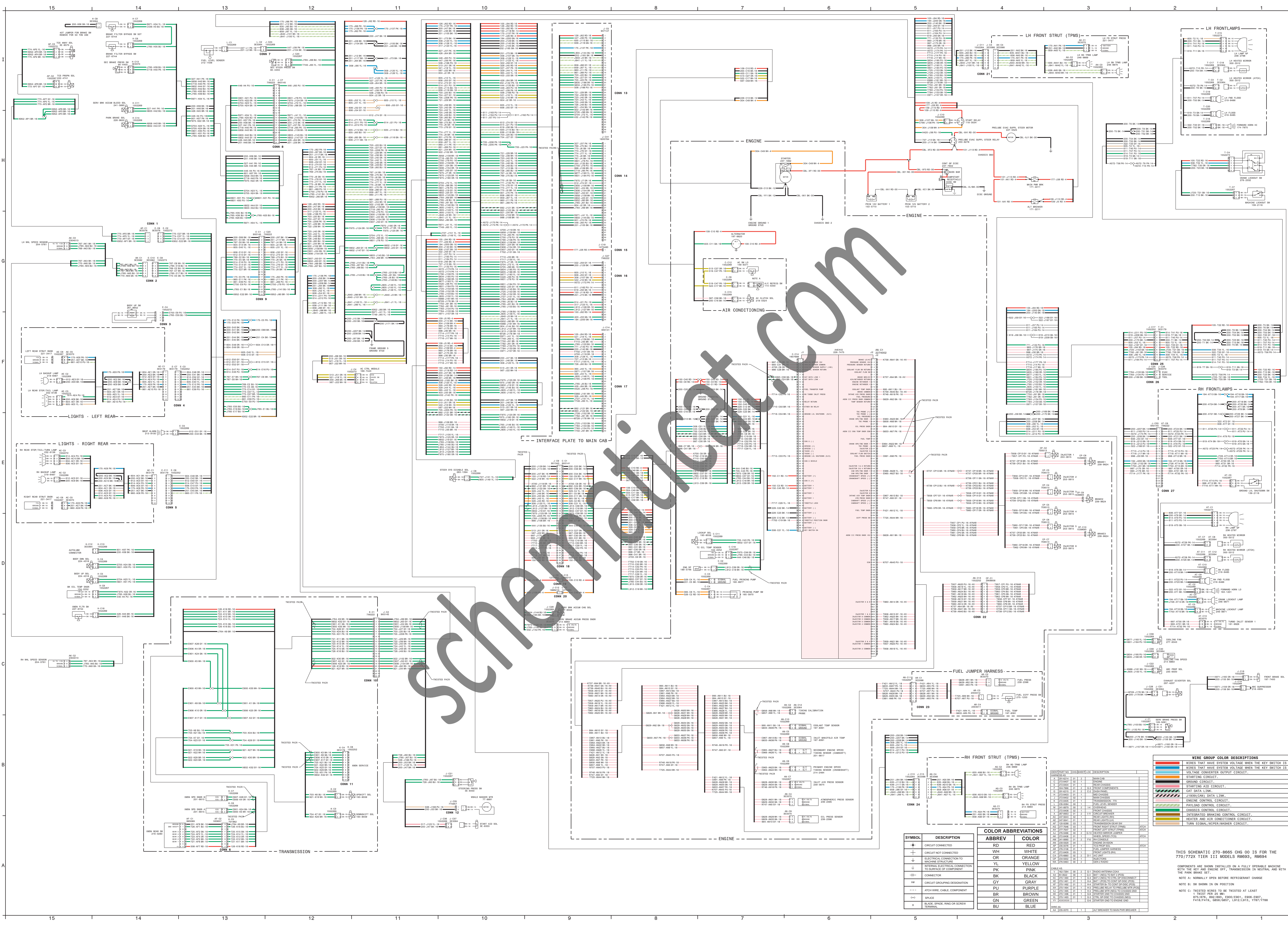

SYMBOL	DESCRIPTION
+	CIRCUIT CONNECTED
+	CIRCUIT PART CONNECTED
+	ELECTRICAL CONNECTION TO MACHINE STRUCTURE
+	INTERNAL ELECTRICAL CONNECTION TO BATTERY OR COMPONENT
+	CONNECTOR
+	CIRCUIT GROUP/COMPONENT DESIGNATION
+	ATTACHMENT CABLE COMPONENT
+	SPRINKLE
+	BLADE SPRING RING OR SCREW TERMINAL

ABBREV	COLOR
RD	RED
WH	WHITE
OR	ORANGE
YL	YELLOW
PK	PINK
BK	BLACK
GY	GRAY
PU	PURPLE
BR	BROWN
GN	GREEN
BU	BLUE

WIRE GROUP COLOR DESCRIPTIONS	
Red	WIRES THAT HAVE SYSTEM VOLTAGE WHEN THE KEY SWITCH IS OFF.
Blue	WIRES THAT HAVE SYSTEM VOLTAGE WHEN THE KEY SWITCH IS ON.
Green	VOLTAGE CONVERTER OUTPUT CIRCUIT.
Orange	STARTING CIRCUIT.
Yellow	GROUND CIRCUIT.
Pink	STARTING AID CIRCUIT.
Black	DATA LINK.
Gray	TRUCK CAN DATA LINK.
Purple	ENGINE CONTROL CIRCUIT.
Brown	ENGINE CONTROL CIRCUIT.
Green	CHASSIS CONTROL CIRCUIT.
Blue	INTEGRATED BRAKING CONTROL CIRCUIT.
Light Blue	HEATER AND AIR CONDITIONING CIRCUIT.
Light Green	TURN SIGNAL/WIPER/WASHER CIRCUIT.

THIS SCHEMATIC 270-8665 CHS 00 IS FOR THE 770/77X TIER III MODELS RM693, RM694

COMPONENTS ARE SHOWN INSTALLED ON A FULLY OPERABLE MACHINE WITH THE KEY AND ENGINE OFF, TRANSMISSION IN NEUTRAL AND WITH THE PARK BRAKE SET.

NOTE A: SHOWN IN ON POSITION

NOTE B: WIRED ITEMS TO BE WIRED AT LEAST 1 INCH FROM 25 AWG

NOTE C: 1.5 INCH FROM 25 AWG

NOTE D: 1.5 INCH FROM 25 AWG

NOTE E: 1.5 INCH FROM 25 AWG

NOTE F: 1.5 INCH FROM 25 AWG

NOTE G: 1.5 INCH FROM 25 AWG

NOTE H: 1.5 INCH FROM 25 AWG

NOTE I: 1.5 INCH FROM 25 AWG

NOTE J: 1.5 INCH FROM 25 AWG

NOTE K: 1.5 INCH FROM 25 AWG

NOTE L: 1.5 INCH FROM 25 AWG

NOTE M: 1.5 INCH FROM 25 AWG

NOTE N: 1.5 INCH FROM 25 AWG

NOTE O: 1.5 INCH FROM 25 AWG

NOTE P: 1.5 INCH FROM 25 AWG

NOTE Q: 1.5 INCH FROM 25 AWG

NOTE R: 1.5 INCH FROM 25 AWG

NOTE S: 1.5 INCH FROM 25 AWG

NOTE T: 1.5 INCH FROM 25 AWG

NOTE U: 1.5 INCH FROM 25 AWG

NOTE V: 1.5 INCH FROM 25 AWG

NOTE W: 1.5 INCH FROM 25 AWG

NOTE X: 1.5 INCH FROM 25 AWG

NOTE Y: 1.5 INCH FROM 25 AWG

NOTE Z: 1.5 INCH FROM 25 AWG

# Schematic

## 770 and 772 Off-Highway Truck Electrical System

770: BZZ1-185  
772: RLB1-349

Volume 2 of 2: Cab

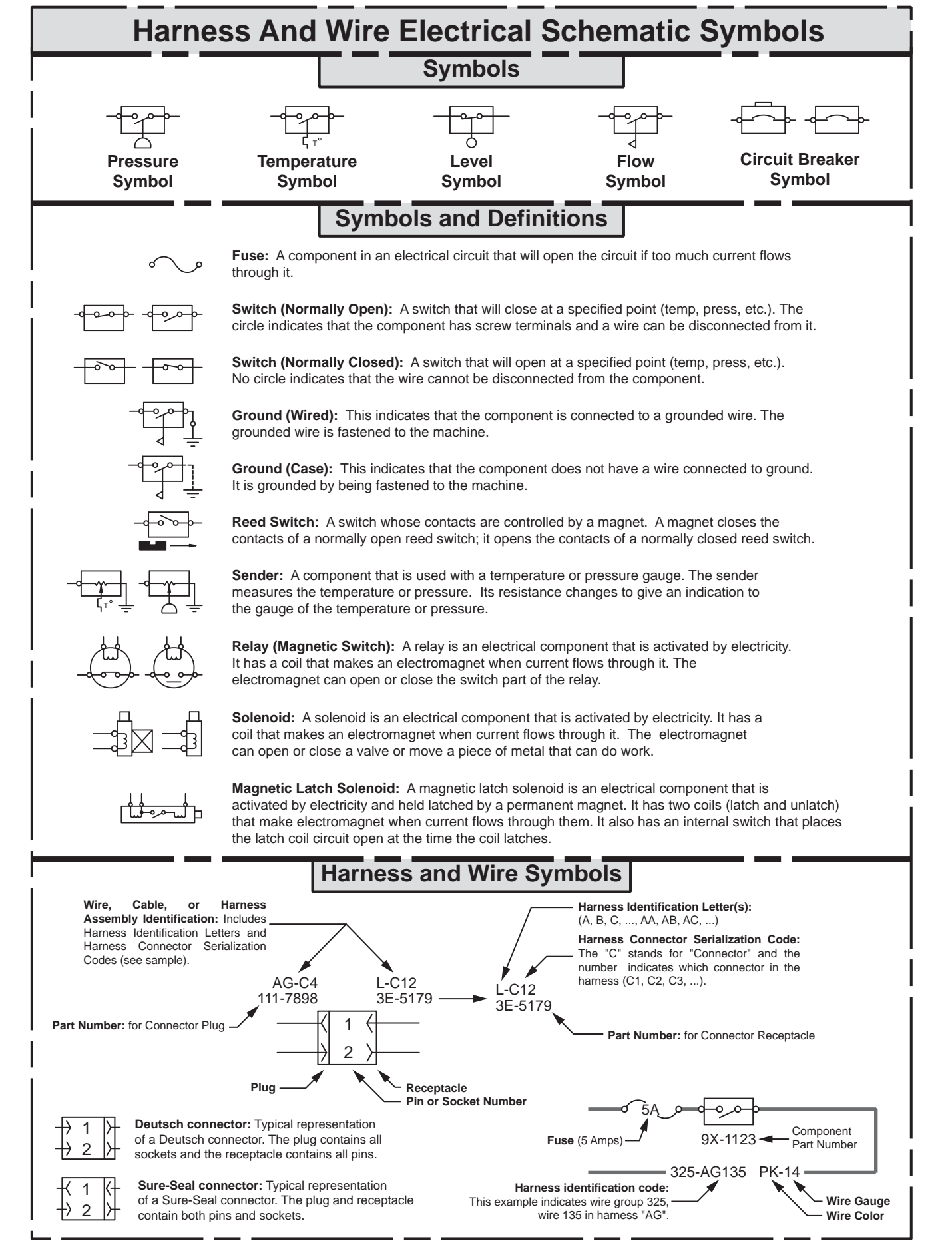

© 2010 Caterpillar  
All Rights Reserved  
Printed in U.S.A.

Related Electrical Service Manuals		
Title	Form Number	
Alarm	228-7683	SEN8130
Electric Starting Motor	231-1962	SEN9390
VIMS/Playload System		REN8264
Chassis Control System		REN8761
Engine Control System		SEN8832

### Component Identifiers (CID)<sup>1</sup> Module Identifier (MID)<sup>2</sup> Chassis Control System (MID No. 087)

CID	Component
0041	8 VDC Sensor Power Supply
0066	Fuel Level Sensor
0144	Backup Alarm Relay
0168	Electronic System Voltage
0177	Transmission Oil Temperature Sensor
0190	Engine Speed Sensor
0379	Autolube Pressure Sensor
0420	Secondary Steering Relay
0444	Starter Motor Relay
0533	Brake ECM
0558	Transmission Output Speed Sensor 1
0590	Autolube Relay
0637	Backup Alarm
0669	Transmission Input Speed Sensor
0673	Transmission Output Speed Sensor 2
0702	Transmission Gear Lever Solenoid Sensor
0709	Transmission Lockup Clutch Solenoid
0715	Transmission System
0724	Host Raise Solenoid
0725	Host Lower Solenoid
0773	Host Lower Solenoid
0806	Torque Converter Oil Temperature Sensor
0927	Machine Application
1245	Accumulator Bleed Relay
1326	ECM Location Code
1401	Transmission Solenoid 1
1402	Transmission Solenoid 2
1403	Transmission Solenoid 3
1404	Transmission Solenoid 4
1405	Transmission Solenoid 5
1406	Transmission Solenoid 6
1407	Transmission Solenoid 7
1674	Proportional Solenoid Feedback Return 1
1675	Proportional Solenoid Feedback Return 2
2177	Primary Steering Shuttle Solenoid
2448	Graphical Display Module

### Engine Control System (MID No. 036)

CID	Component
0001	Cylinder 1 Injector Solenoid
0002	Cylinder 2 Injector Solenoid
0003	Cylinder 3 Injector Solenoid
0004	Cylinder 4 Injector Solenoid
0005	Cylinder 5 Injector Solenoid
0006	Cylinder 6 Injector Solenoid
0007	Cylinder 7 Injector Solenoid
0008	Cylinder 8 Injector Solenoid
0009	Cylinder 9 Injector Solenoid
0010	Cylinder 10 Injector Solenoid
0011	Cylinder 11 Injector Solenoid
0012	Cylinder 12 Injector Solenoid
0041	8 Volt DC Supply Short
0091	Throttle Position Signal
0094	Fuel Pressure
0100	Engine Oil Pressure
0110	Engine Oil Pressure Sensor
0168	System Voltage
0172	Intake Manifold Air Temperature
0174	Fuel Temperature
0190	Engine Speed Signal
0253	Personality Module
0261	Engine Timing
0262	5 Volt Sensor DC Power Supply
0267	Incorrect Engine Shutdown Switch
0268	System Parameters
0274	Atmospheric Pressure
0291	Engine Cooling Fan Solenoid
0342	Secondary Engine Speed
0533	Brake Control
0544	Engine Cooling Fan Speed Sensor
0569	Oil Injection Solenoid
1273	Chassis Control Module
1589	Turbo Inlet Air Pressure Sensor
1785	Intake Manifold Air Pressure Sensor
1795	Turbo #2 Outlet Pressure Sensor
1796	Intake Manifold #2 Air Temperature Sensor
2271	Engine Oil Return System Actuation Solenoid
2417	Either Injection Control Solenoid
2533	Compression Brake Low/High Solenoid #1 Low Current
2534	Compression Brake Low/High Solenoid #2 High Current
2535	Compression Brake Medium/High Solenoid #1 Low Current
2536	Compression Brake Medium/High Solenoid #2 High Current

### TPMS/VIMS Control System

267	Remote Shutdown Input
533	Brake Control
580	Engine Control Module
824	TPMS Lamp #1 (GREEN)
825	TPMS Lamp #2 (RED)
838	Left Front Strut Pressure Sensor
839	Right Front Strut Pressure Sensor
840	Left Rear Strut Pressure Sensor
841	Right Rear Strut Pressure Sensor
890	Telemetry Data Link
1273	Chassis Control Module
2183	Payload Monitoring System
2448	Graphical Display Module

<sup>1</sup>The CID is a diagnostic code that indicates which circuit is faulty.  
<sup>2</sup>The MID is a diagnostic code that indicates which electronic control module diagnosed the fault.

### Failure Mode Identifiers (FMI)<sup>1</sup>

FMI No.	Failure Description
0	Data valid but above normal operational range.
1	Data valid but below normal operational range.
2	Data erratic, intermittent, or incorrect.
3	Voltage above normal or shorted high.
4	Voltage below normal or shorted low.
5	Current below normal or open circuit.
6	Current above normal or grounded circuit.
7	Mechanical system not responding properly.
8	Abnormal frequency, pulse width, or period.
9	Abnormal update.
10	Abnormal rate of change.
11	Failure mode not identifiable.
12	Bad device or component.
13	Out of calibration.
14	Parameter failures.
15	Parameter failures.
16	Parameter not available.
17	Module not responding.
18	Sensor supply fault.
19	Condition not met.
20	Parameter failures.

<sup>1</sup>The FMI is a diagnostic code that indicates what type of failure has occurred.

Connector Location		
Connector Number	Schematic Location	Machine Location
CONN 13	C-10	L3
CONN 14	B-10	L4
CONN 15	B-8	L5
CONN 16	D-8	L6
CONN 17	C-8	L7
CONN 28	L-13	3
CONN 29	L-10	C
CONN 30	L-10	C
CONN 31	L-10	C
CONN 32	G-10	2
CONN 33	C-10	3
CONN 34	A-8	3
CONN 35	G-8	D
CONN 36	L-5	C
CONN 37	D-5	B
CONN 38	L-5	B
CONN 39	H-4	B
CONN 40	G-4	B
CONN 41	F-3	B
CONN 42	E-1	4

The connectors shown in this chart are for harness to harness connectors. Connectors that join a harness to a component are generally located at or near the component. See the Component Location Chart.

Component Location					
Component	Schematic Location	Machine Location	Component	Schematic Location	Machine Location
Air Seat	L-13	1	Relay, Main	L-8	C
Alarm, Audible	L-8	C	Relay, Terminal / Fuse / Breaker	L-1	B
Alarm, Visual	G-1	C	Resistor, Blower	D-1	D
Breaker, A/C	L-8	C	Sensor, Host Position	F-6	D
Breaker, A/24M III	L-8	C	Sensor, Secondary Brake Preset	C-6	S
Breaker, HD, amp	L-5	C	Sensor, Shift Lever	G-6	D
Bushead Connector (Video)	A-8	A	Sensor, Throttle Position	C-6	C
Cable As. CAN	A-8	A	Socket, 2x Power	L-8	C
Cable As. RAD	A-9	A	Speaker, Left	L-3	A
Cigar Lighter	E-3	B	Speaker, Right	L-3	A
Control, Chassis	A-14	3	Switch, A/C Enable	C-3	B
Control, TPMS	D-15	3	Switch, ARC On / Off	E-3	B
Converter, 28V / 12V	L-13	3	Switch, Backlight Adjust	C-3	B
Flasher	H-2	B	Switch, Blower	B-4	B
Fuse Block	L-7	C	Switch, Compression Brake	B-3	B
Instrument Cluster	D-3	B	Switch, Drowsy Lamp	H-2	4
Lamp, Backlight Blower Sw.	A-5	B	Switch, Front Brake	C-3	B
Lamp, Backlight Key Start Sw.	B-5	B	Switch, Hazard	E-3	B
Lamp, Right Dome	L-2	B	Switch, Headlamp	E-3	B
Messenger	B-3	B	Switch, Hand Mirror	B-3	B
Monitor, Instrument Water Delay	F-3	B	Switch, Instrument Water Delay	H-2	B
Monitor, Rear Vision	A-7	A	Switch, Key Start	B-4	B
Motor, Blower	D-1	4	Switch, Retarder Lever	G-3	7
Motor, Front Wiper	E-1	B	Switch, Secondary Steering	B-3	B
Product Link 300	F-8	3	Switch, TCS Test	B-3	B
Radio 12V	F-3	A	Switch, Temp Select	A-4	B
Radio, Day 2	F-10	3	Switch, Thermostat	D-1	4
Relay, Bsa	G-14	3	Switch, Throttle Lock	C-3	B
Relay, Driver	G-10	C	Switch, Wiper / Washer / Turn	G-4	7
Relay, Heated Mirror	G-9	C	Water Valve	C-1	4

Machine locations are repeated for components located close together.  
A - Inside of Cab  
B - Inside of Dash  
C - Circuit Breaker / Fuse Panel  
D - Inside of Console

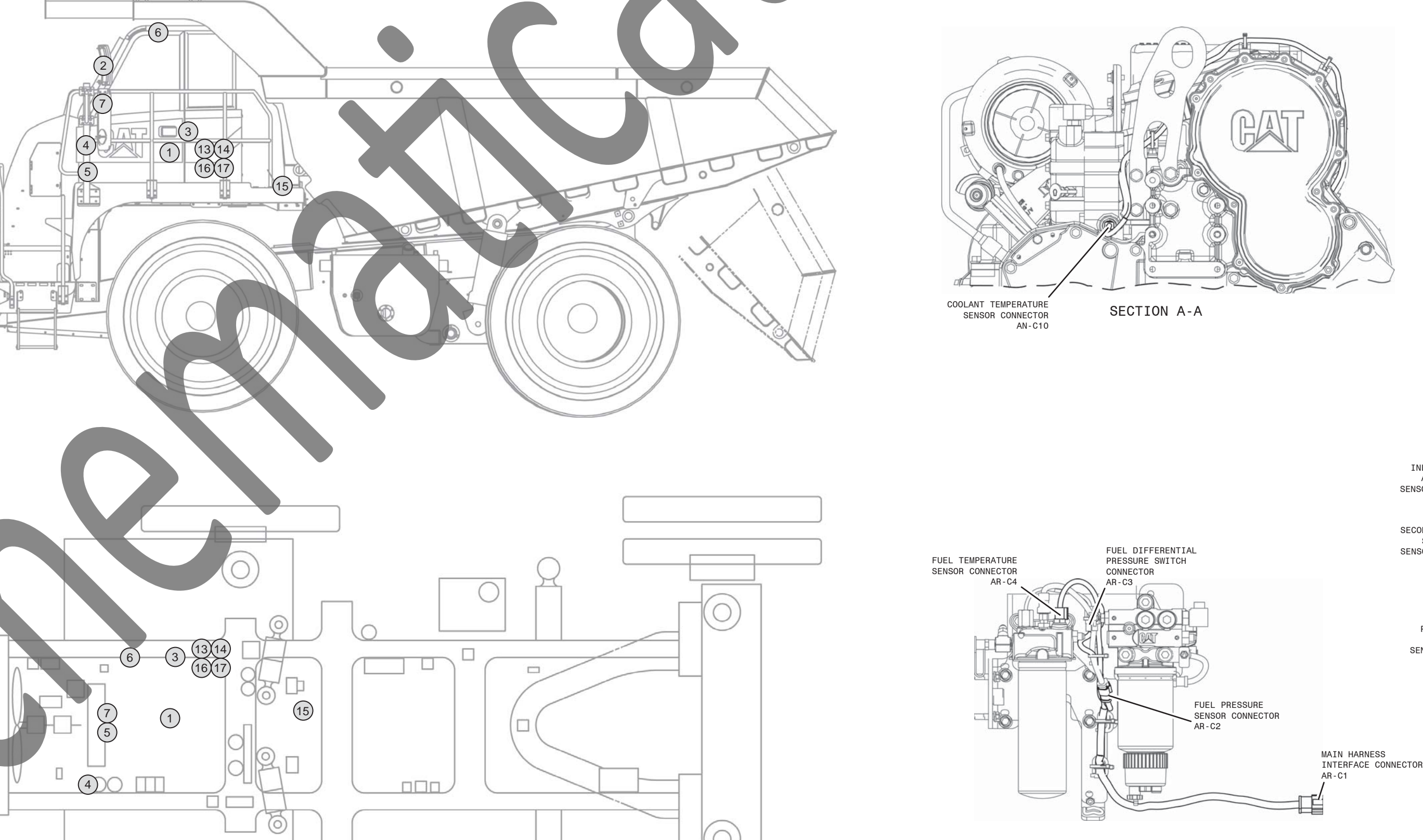

Event Codes Engine Control		
Event Code	Condition	
E098	High Fuel Pressure	
E171	Low Engine Oil Level	
E172	High Oil Filter Restriction	
E194	High Exhaust Temperature	
E360	Low Engine Oil Pressure	
E361	High Engine Coolant Temperature	
E362	Engine Overspeed	
E363	High Fuel Supply Temperature	
E390	Fuel Filter Restriction	
E539	High Intake Manifold Air Temperature	
E540	Low Engine Oil Refill Tank Level	
E1000	High Left Brake Manifold Air Temperature	

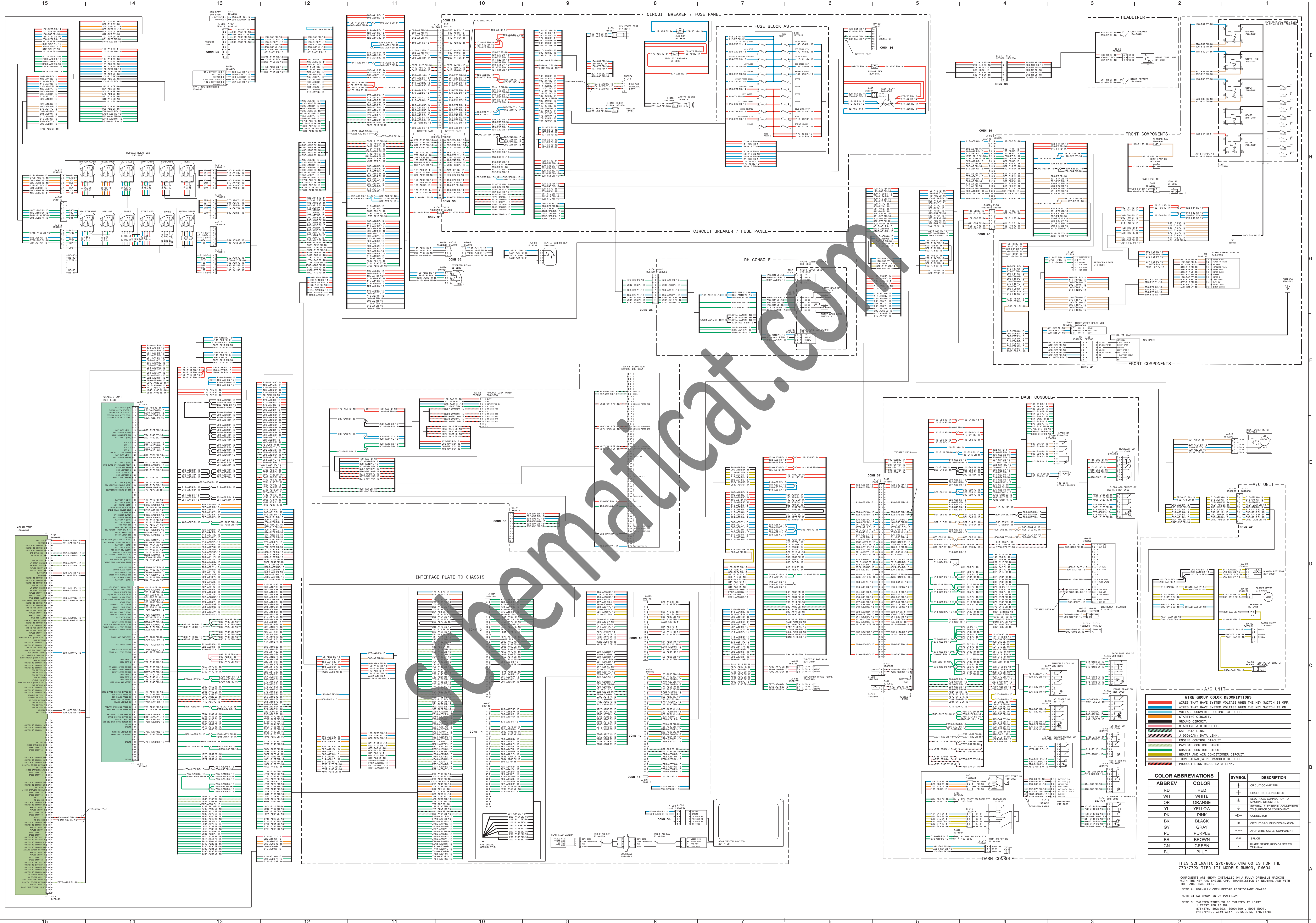

WIRE GROUP COLOR DESCRIPTIONS	
[Red line]	WIRES THAT HAVE SYSTEM VOLTAGE WHEN THE KEY SWITCH IS OFF.
[Blue line]	WIRES THAT HAVE SYSTEM VOLTAGE WHEN THE KEY SWITCH IS ON.
[Orange line]	VOLTAGE CONVERTER OUTPUT CIRCUIT.
[Green line]	STARTING CIRCUIT.
[Yellow line]	STARTING AID CIRCUIT.
[Purple line]	CAT DATA LINK.
[Pink line]	INTERCOM DATA LINK.
[Light Blue line]	ENGINE CONTROL CIRCUIT.
[Light Green line]	FAULT CODE CONTROL CIRCUIT.
[Light Yellow line]	CHASSIS CONTROL CIRCUIT.
[Light Purple line]	HEATER AND AIR CONDITIONER CIRCUIT.
[Light Orange line]	TURBO SIGNAL, TURBO MANAGER CIRCUIT.
[Light Green line]	PRODUCT LHM RS232 DATA LINK.

COLOR ABBREVIATIONS	
RD	RED
WH	WHITE
OR	ORANGE
YL	YELLOW
PK	PINK
BK	BLACK
GY	GRAY
PU	PURPLE
BR	BROWN
GN	GREEN
BU	BLUE

SYMBOL DESCRIPTION	
[Solid line]	CIRCUIT CONNECTED
[Dashed line]	CIRCUIT NOT CONNECTED
[Line with crossbar]	ELECTRICAL CONNECTION TO MACHINE STRUCTURE
[Line with dot]	INTERNAL ELECTRICAL CONNECTION TO SURFACE OF COMPONENT
[Line with circle]	CONNECTION
[Line with triangle]	CIRCUIT GROUPING DESIGNATION
[Line with square]	ATTACHMENT CABLE COMPONENT
[Line with diamond]	SPlice
[Line with hexagon]	BLADE, SPIDE, RING OR SCREW TERMINAL

THIS SCHEMATIC 270-8665 CHG 00 IS FOR THE 770/772X TIER III MODELS RM69S, RM94

COMPONENTS ARE SHOWN INSTALLED ON A FULLY OPERABLE MACHINE WITH THE KEY AND ENGINE OFF, TRANSMISSION IN NEUTRAL AND WITH THE PARK BRAKE SET.

NOTE A: NORMALLY OPEN BEFORE REFRIGERANT CHARGE

NOTE B: SW SHOWN IN ON POSITION

NOTE C: TESTED WIRES TO BE TESTED AT LEAST 1 TEST PER SW SW: 875/876, 892/893, 8200/8201, 8906/8907, 8718/8719, 8925/8927, 8712/8713, 8717/8718