

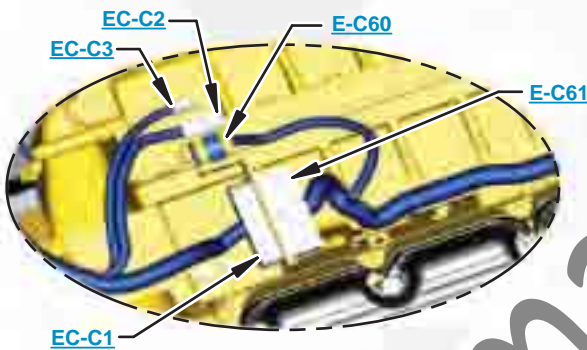

This document is best viewed at a screen resolution of 1024 X 768.

To set your screen resolution do the following:
RIGHT CLICK on the **DESKTOP**.
 Select **PROPERTIES**.
CLICK the **SETTINGS TAB**.
MOVE THE SLIDER under **SCREEN RESOLUTION** until it shows **1024 X 768**.
CLICK OK to apply the resolution.

The Bookmarks panel will allow you to quickly navigate to points of interest.



Click on any text that is BLUE and underlined. These are hyperlinks that can be used to navigate the schematic and machine views.

VIEW ALL CALLOUTS

When only one callout is showing on a machine view this button will make all of the callouts visible. This button is located in the top right corner of every machine view page.

HOTKEYS (Keyboard Shortcuts)		
	FUNCTION	KEYS
	Zoom In	"CTRL" / "+"
	Zoom Out	"CTRL" / "-"
	Fit to Page	"CTRL" / "0" (zero)
	Hand Tool	"SPACEBAR" (hold down)
	Find	"CTRL" / "F"



Schematic

950H and 962H Wheel Loader IT62H Integrated Toolcarrier Electrical System

950H:

N1A1-3212

JAD1-187

M1G1-1782

J5J1-UP

K5K1-434

962H:

N4A1-1256

M3G1-541

J6J1-UP

K6K1-434

IT62H:

M5G1-475

Volume 1 of 2: Chassis**Volume 2 of 2: Cab**

COMPONENT LOCATION

Volume 1 of 2 - CHASSIS



Component	Schematic Location	Machine Location	Component	Schematic Location	Machine Location
AIH	E-13	1	Sensor - Rail Pressure	E-16	1
Alarm - Backup	C-17	2	Sensor - Rear Axle Oil Temp.	A-12	21
Alternator	G-13	3	Sensor - Rotary Lift Position	L-3	22
Arc Suppressor - A/C	B-14	3	Sensor - Rotary Tilt Position	L-2	23
Arc Suppressor - Quick Coupler	L-1	4	Sensor - Speed Timing Group	C-16	17
Arc Suppressor - Secondary Steering	J-10	5	Sensor - Trans. Output Speed (Leading)	H-10	24
Arc Suppressor - Start Relay	I-15	6	Sensor - Trans. Output Speed (Trailing)	I-10	24
Batteries	L-13	7	Sensor - Transmission Input Speed	I-10	25
Block Asm.	L-14	7	Sensor - Transmission Oil Temperature	I-10	26
Breaker - AIH	I-15	6	Sensor - Turbo Inlet Pressure	G-8	27
Breaker - Alternator	I-15	6	Solenoid - A/C Clutch	A-14	3
Breaker - Belly Guard Actuator	L-15	6	Solenoid - Auto Reversing Fan	C-17	28
Breaker - Hood Actuator	K-15	6	Solenoid - Aux Third Function (Forward)	E-2, I-2	20
Breaker - Main	J-15	6	Solenoid - Aux Third Function (Rearward)	C-2, H-2	20
Breaker - Running Lamp	K-15	6	Solenoid - Axle Cooler Clutch	G-13	1
Breaker - Start	I-15	6	Solenoid - Dump Anti-Drift	D-2, I-3	20
Breaker - Unswitched Bus (Cab)	J-15	6	Solenoid - Dump Prop	D-2, I-2	20
Control - Engine	G-15	8	Solenoid - Lower Anti-Drift	D-2, I-3	20
Control - Hood Raise/Lower	K-14	6	Solenoid - Lower Prop	D-2, H-2	20
Motor - Belly Guard	L-15	10	Solenoid - Pilot Hydraulic Supply	C-2, H-2	20
Motor - Front Washer	C-7	11	Solenoid - Quick Coupler	L-1	4
Motor - Fuel Priming Pump	A-14	1	Solenoid - Rack Back Prop	D-2, I-2	20
Motor - Hood Actuator	G-16	12	Solenoid - Raise Prop	D-2, H-2	20
Motor - Rear Washer	C-7	11	Solenoid - Start Aid	E-10	29
Motor - Secondary Steering	J-10	5	Solenoid - Variable Speed Fan	G-13	28
Motor - Starter	K-12	13	Solenoids - Cylinder Head (1 - 6)	F-18	30
Pump- Autolube	B-7	9	Solenoids - Ride Control (1-3)	E-2, H-3	20
Relay - AIH	E-13	1	Solenoids - Trans. Clutch	I-11	25
Relay - Main	J-15	6	Switch - A/C Refrigerant	B-14	3
Relay - Secondary Steering Intermediate	K-11	5	Switch - Autolube Pressure	B-7	31
Relay - Start	I-15	6	Switch - Belly Guard Actuator	L-15	6
Resistor - CAN	E-10	8	Switch - Brake Oil Pressure	G-13	3
Sender - Fuel Level	H-17	14	Switch - Bucket Position	G-1	32
Sender - T/C Temperature	E-10	15	Switch - Disconnect	L-13	6
Sensor - Atmospheric Pressure	E-16	16	Switch - Fork Position	G-1	32
Sensor - Boost Pressure	E-16	16	Switch - Fuel Pressure	D-16	1
Sensor - Coolant Temperature	D-16	17	Switch - Fuel Priming Pump	A-14	1
Sensor - Front Axle Oil Temperature	K-2	18	Switch - Ground Level Shutdown	H-14	6
Sensor - Fuel Pressure	D-17	1	Switch - Hood Actuator	H-14	6
Sensor - Hydraulic Oil Temperature	I-6	19	Switch - Hydraulic Filter Bypass Pressure	D-6	33
Sensor - Intake Manifold Air Temp	D-16	16	Switch - Park Brake Pressure	D-6	34
Sensor - Lift Cylinder Head End Pressure	L-3	20	Switch - Primary Steering Pressure	J-9	5
Sensor - Lift Position	G-2	20	Switch - Secondary Steering Pressure	J-9	5
Sensor - Oil Pressure	D-16	17	Switch - Trans Filter Bypass	D-6	33

COMPONENT LOCATION

Volume 2 of 2 - CAB



Component	Schematic Location	Machine Location	Component	Schematic Location	Machine Location
Alarm - Action	E-15	45	Sensor - Tilt Lever Position	G-7	47
Alarm - Implement Audible Alert	E-15	45	Switch - Auto/Manual Gear Select	D-4	46
Alarm - Quick Coupler	D-1	46	Switch - Autodig Kickout Set	C-1	46
Arc Suppressor - Forward Horn	I-7	47	Switch - Autodig Mode	D-3	46
Control - Dimmer	D-15	45	Switch - Autodig Mode Select	C-1	46
Control - Implement	F-13	49	Switch - Autodig Trigger	G-7	47
Control - Payload Control System	D-7	50	Switch - Beacon	G-3	52
Control - Transmission Control	L-18	51	Switch - Blower Fan Speed	D-6	48
Converter - Voltage (10A)	F-15, G-16	51	Switch - Bucket/Fork Select	E-2	46
Diode - Blower Motor	K-15	51	Switch - Cat Mon Sys Mode Select	C-6	48
Display - Groeneveld Autolube	F-7	48	Switch - Dimmer	H-1	57
Flasher - 24V	E-15	45	Switch - Downshift	F-7	47
Fuse - Block	B-15	45	Switch - Fine Modulation	F-8	47
Fuse - Thermal Cut Out	K-15	51	Switch - Forward Horn	I-3	58
Guage - Quad	J-1	52	Switch - Forward Horn 2	G-7	47
Indicator - Center Dash	K-1	52	Switch - Front Intermittent Wiper/Washer	D-5	48
Indicator - Left Hand Panel	K-1	52	Switch - Hazard Lamp	H-3	52
Indicator - Right Hand Panel	K-1	52	Switch - Heated Mirror	E-2	46
Joystick - Implement Control	I-7	47	Switch - HID Lamp	J-3	52
Keypad - WLPCS	C-7	50	Switch - HVAC Select	D-6	48
Monitor	E-7	48	Switch - Implement Lockout	G-8	47
Motor - Blend Door Actuator	L-15	51	Switch - Key Start	G-3	52
Motor - Blower	L-16	51	Switch - Lift Tilt Kickout Set	E-1	46
Motor - Front Wiper	I-1	53	Switch - Neutral Override	C-2	46
Motor - Rear Wiper	K-14	54	Switch - Quick Coupler	D-1	46
Potentiometer - HVAC Temperature Select	D-5	48	Switch - Rear Wiper/Washer	E-4	46
Product Link	J-1	51	Switch - Remote FNR	H-7	47
Radio - Product Link	K-11	51	Switch - Reversing Fan	D-1	46
Relay - Axle Cooler	C-5	45	Switch - Ride Control	C-2	46
Relay - Forward Cab Floodlamp	C-15	45	Switch - Running Lamp	K-3	52
Relay - Forward Horn	C-15	45	Switch - Secondary Steering Test	D-2	46
Relay - Heated Mirrors Timer	D-15	45	Switch - Stop Lamp	H-1	55
Relay - Rear Floodlamp	C-15	45	Switch - Third Function Control Flow	K-3	52
Resistor A/C (1)	L-14	45	Switch - Third Function Diverter	G-8	47
Resistor A/C (2)	L-14	45	Switch - Transmission Gear Selector	I-3	58
Resistor - Blower Motor	K-16	51	Switch - Transmission Shifter Assembly	H-2	58
Resistor - CAN A	K-6	52	Switch - Turn Signal	I-2	58
Sensor - 3rd Lever Position	F-7	47	Switch - Variable Shift Control	D-3	46
Sensor - Left Hand Brake Pedal	H-1	55	Tach/Speedometer	J-1	52
Sensor - Lift Lever Position	G-7	47	Thermostat	K-15	51
Sensor - Throttle Position	G-1	56			

CONNECTOR LOCATION

Volume 1 of 2 - CHASSIS



Connector Number	Schematic Location	Machine Location
CONN 1	D-17	2
CONN 2	D-17	2
CONN 3	I-18	35
CONN 4	I-18	35
CONN 5	C-16	6
CONN 6	D-16	16
CONN 7	F-16	1
CONN 8	L-13	6
CONN 9	A-12	36
CONN 10	E-10	37
CONN 11	F-10	13
CONN 12	F-10	13
CONN 13	I-9	5
CONN 14	C-8	38
CONN 15	C-8	34
CONN 16	I-7	39
CONN 17	H-7	39
CONN 18	G-7	39
CONN 19	E-7	39
CONN 20	J-4	40
CONN 21	J-3	41
CONN 22	J-3	22
CONN 23	L-3	42
CONN 24	L-3	20
CONN 25	K-2	20
CONN 26	G-2	43
CONN 47	B-7	44
CONN 48	B-7	9

The connectors shown in this chart are for harness to harness connectors. Connectors that join a harness to a component are generally located at or near the component. See the Component Location Chart.

CONNECTOR LOCATION

Volume 2 of 2- CAB



Connector Number	Schematic Location	Machine Location
CONN 16	E-18	54
CONN 17	D-18	59
CONN 18	C-18	54
CONN 19	B-18	54
CONN 27	F-15	45
CONN 28	E-15	45
CONN 29	L-13	51
CONN 30	H-12	51
CONN 31	H-9	47
CONN 32	G-9	47
CONN 33	F-9	45
CONN 34	D-8	48
CONN 35	L-7	60
CONN 36	L-7	61
CONN 37	K-7	60
CONN 38	K-7	62
CONN 39	D-7	63
CONN 40	I-3	52
CONN 41	I-3	52
CONN 42	H-3	58
CONN 43	F-3	52
CONN 44	F-2	52
CONN 45	H-1	57
CONN 46	G-1	55

CID / MID / FMI

Volume 1 of 2 - CHASSIS



Component Identifiers (CID ¹) Module Identifier (MID ²) Engine Control System (MID No. 036)	
CID	Component
0001	Fuel Injector Solenoid #1
0002	Fuel Injector Solenoid #2
0003	Fuel Injector Solenoid #3
0004	Fuel Injector Solenoid #4
0005	Fuel Injector Solenoid #5
0006	Fuel Injector Solenoid #6
0041	ECM 8V DC Supply
0042	Injector Actuation Valve
0091	Throttle Sensor
0094	Fuel Pressure Sensor
0100	Oil Pressure Sensor
0110	Engine Coolant Temperature Sensor
0164	Injector Actuation Pressure Sensor
0168	Electrical Power Supply
0172	Intake Manifold Air Temperature Sensor
0190	Engine Speed Sensor
0253	Personality Module
0261	Engine Speed Sensor
0262	5 Volt Sensor Supply
0267	Engine Shutdown Switch
0268	Check Programmable Parameters
0269	Sensor Power Supply
0274	Atmospheric Pressure Sensor
0275	Right Turbo Inlet Pressure Sensor
0283	Filter Restrict Lamp
0291	Engine Cooling Fan Solenoid
0296	Transmission ECM
0342	Camshaft Position Sensor
0596	Implement Control
1639	Machine Security System
1785	Intake Manifold Pressure Sensor

¹ The CID is a diagnostic code that indicates which circuit is faulty.

² The MID is a diagnostic code that indicates which electronic control module diagnosed the fault.

Failure Mode Identifiers (FMI) ¹	
FMI No.	Failure Description
0	Data valid but above normal operational range.
1	Data valid but below normal operational range.
2	Data erratic, intermittent, or incorrect.
3	Voltage above normal or shorted high.
4	Voltage below normal or shorted low.
5	Current below normal or open circuit.
6	Current above normal or grounded circuit.
7	Mechanical system not responding properly.
8	Abnormal frequency, pulse width, or period.
9	Abnormal update.
10	Abnormal rate of change.
11	Failure mode not identifiable.
12	Bad device or component.
13	Out of calibration.
14	Parameter failures.
15	Parameter failures.
16	Parameter not available.
17	Module not responding.
18	Sensor supply fault.
19	Condition not met.
20	Parameter failures.

¹The FMI is a diagnostic code that indicates what type of failure has occurred.

Event Codes Engine Control	
Event Code	Condition
E096	High Fuel Pressure
E172	High Air Filter Restriction
E194	High Exhaust Temperature
E198	Low Fuel Pressure
E360	Low Engine Oil Pressure
E361	High Engine Coolant Temperature
E362	Engine Overspeed
E390	Fuel Filter Restriction
E441	Idle Elevated to Increase Battery Voltage
E539	High Intake Manifold Air Temperature



Component Identifiers (CID¹)	
Module Identifier (MID²)	
Caterpillar Monitoring System	
(MID No. 030)	
CID	Component
0096	Fuel Level Sender
0100	Engine Oil Pressure Sensor
0110	Engine Coolant Temperature Sensor
0177	Torque Converter Oil Temperature Sensor
0248	Data Link
0263	Sensor Power Supply
0271	Action Alarm
0324	Action Lamp
0600	Hydraulic Oil Temperature Sensor
0819	Display Data Link
0821	Display Power Supply
0826	T/C Oil Temperature Sensor
0830	Brake Oil Temperature Sensor
Payload Control System	
(MID No. 074)	
CID	Component
0248	CAT Data Link
0364	Head End Lift Cylinder Pressure Sensor
0591	PCS EEPROM
0769	Rod End Lift Cylinder Pressure Sensor
1964	Lift Position Sensor
Electronic Transmission Control System	
(MID No. 081)	
CID	Component
0041	8 Volt DC Supply
0168	Electrical System Voltage
0177	Transmission Oil Temperature Sensor
0190	Engine Speed Sensor
0262	5 Volt DC Supply
0268	Programmed Parameter Fault
0367	Ride Control Switch
0368	Transmission Auto/Manual Switch
0444	Start Relay
0562	Electronic Monitoring System
0585	Transmission Output Speed Sensor 1
0590	Engine Control Module
0596	Implement Control
0623	Directional Switch
0627	Parking Brake Pressure Sw.
0672	Transmission Input Speed Sensor
0673	Transmission Output Speed Sensor 2
0702	Lever Switch (Transmission Shifting/Direction)
0737	Left Brake Pedal Position Sensor
0793	Primary Steering Pressure Switch
0794	Secondary Steering Pressure Switch
0795	Secondary Steering Relay
0967	Machine Application
1326	ECM Location Code
1400	Rear Axle Oil Cooler Solenoid
1401	Reverse Solenoid
1402	Forward Solenoid
1403	Fourth Speed Clutch
1404	Third Speed Clutch
1405	Second Speed Clutch
1406	First Speed Clutch
1521	Part-Throttle Autoshift Selector Switch
1960	Ignition Key Reader
2129	Ride Control Solenoid (1)
2274	Transmission Direction Switch #2
2347	Ride Control Solenoid (2)
2684	Ride Control Solenoid (3)

Failure Mode Identifiers (FMI)¹	
FMI No.	Failure Description
0	Data valid but above normal operational range.
1	Data valid but below normal operational range.
2	Data erratic, intermittent, or incorrect.
3	Voltage above normal or shorted high.
4	Voltage below normal or shorted low.
5	Current below normal or open circuit.
6	Current above normal or grounded circuit.
7	Mechanical system not responding properly.
8	Abnormal frequency, pulse width, or period.
9	Abnormal update.
10	Abnormal rate of change.
11	Failure mode not identifiable.
12	Bad device or component.
13	Out of calibration.
14	Parameter failures.
15	Parameter failures.
16	Parameter not available.
17	Module not responding.
18	Sensor supply fault.
19	Condition not met.
20	Parameter failures.

¹The FMI is a diagnostic code that indicates what type of failure has occurred.

Electronic Implement Control (MID No. 082)	
CID	Component
0041	8 Volt DC Supply
0168	Electrical System Voltage
0268	Programmed Parameter Fault
0296	Transmission Control
0350	Lift Linkage Position Sensor
0351	Tilt Linkage Position Sensor
0352	Lift Lever Position Sensor
0353	Tilt Lever Position Sensor
0354	Raise Solenoid
0355	Lower Solenoid
0356	Dump Solenoid
0357	Rackback Solenoid
0358	Pilot Pressure Solenoid
0364	Lify Cylinder Head End Oil Pressure Sensor
0365	Kickout Set Switch
0487	3rd Lever Position Sensor
0490	Implement Lockout Switch
0491	3rd Function Forward Solenoid
0492	3rd Function Rearward Solenoid
0562	Caterpillar Monitoring System
0590	Engine Electronic Control Module
0965	Autodig Dig Mode Switch
0967	Machine Application
1187	Continuous Flow Rocker Switch
1324	Autodig Operation Mode Select Switch
1325	Autodig Trigger Switch
1326	ECM Location Code
1592	Autodig Kickout Set Switch
1639	Machine Security System ECM
1718	Fine Modulation Switch
2326	Lower Anti-Drift Solenoid Valve
2328	Dump Anti-Drift Solenoid Valve
Product Link Radio (MID No. 122)	
CID	Component
0168	Electrical System Voltage
0254	Electronic Control Module
0269	Sensor Power Supply
1250	Remote Communication Module
1251	Alternator "R" Terminal
Machine Security System (MID No. 124)	
CID	Component
0168	Electrical System Voltage
0248	Data Link
0817	ECM Internal Backup Battery
1391	Theft Deterent Output Driver #1
1392	Theft Deterent Output Driver #2

¹ The CID is a diagnostic code that indicates which circuit is faulty.

² The MID is a diagnostic code that indicates which electronic control module diagnosed the fault.

WIRE DESCRIPTION

Volume 1 of 2 - CHASSIS, Page 1 of 2



Wire Description					
Wire Number	Wire Color	Description	Wire Number	Wire Color	Description
Power Circuits			Control Circuits Continued		
101	RD	Bat (+)	F766	WH	Bucket Position Sw / Fork Position Sw
102	RD	Head Lmp	G764	PK	Park Brake Lever Sw to Gnd
103	RD	AIH Breaker	H702	PU	Implement Control Reversing Fan Sw (N.O.)
106	WH	Tilt / Lift Position Sensors	H703	YL	Implement Control Reversing Fan Sw (N.C.)
110	RD	Engine ECM	H704	PK	Implement Control Reversing Fan Sol
112	PU	Main Power Relay Output	H713	PK	Implement Control Lift Proportional Sol
114	RD	Warning Horn (Forward)	H714	OR	Implement Control Lower Proportional Sol
124	GN	A/C	H717	BR	Implement Control Pilot Press Sol
133	OR	LH/RH Dash Indicator Panel	H718	GY	Implement Control Tilt Cylinder Position
136	GN	Supplementary Steering	H746	YL	Fan Control Sol Positive
138	GN	Auto Lube Pump To Payload Monitor	H747	BR	Fan Control Sol Return
141	RD	Beacon / Heated Mirror	H795	PK	Throttle Sensor Common
146	GY	Rotary Tilt Position Sensor	J764	BR	Xmsn Oil Temperature Sensor Ground
147	RD	ECAP/Center Dash Indicator Panel/Autolube	N707	PU	Fuel Pressure Sw
150	OR	Engine ECM/Implement ECM/Transmission ECM	P739	BU	Axle Cooler Clutch
174	RD	Unswitched Fuse Bus Power	P793	BU	Axle Cooler Clutch
175	RD	Hood Actuator Breaker	R746	PK	Boost Pressure Sensor Ground
199	RD	Hood Actuator	R747	GY	Atmospheric Press Sensor
Ground Circuits			T725	WH	Fuel Filter Sw
200	BK	Main Chassis	Y794	OR	Expanded Can Data Link +
201	BK	Operator Monitor Return	Y795	GN	Expanded Can Data Link -
202	BK	Xmsn Ctrl	838	YL	Front Guard Motor
229	BK	Engine ECM	839	BU	Front Guard Motor
C214	BK	Rotary Tilt Position Sensor	G826	BR	Engine ECM Sensor +5v
C216	BK	Implement Return	G827	BU	Engine ECM Pressure Sensor Return
Basic Machine Circuits			G828	WH	Engine ECM Pressure Sensor +5v
304	WH	Start Relay to Starter Motor	G829	GN	Engine ECM Pressure Sensor Common
306	GN	Start Relay to Transmission ECM	G833	PK	Engine ECM Temperature Sensor Common
308	YL	Main Power Relay Coil	G849	BR	Engine Injection Actuation Pressure
321	BR	Backup Alarm Lamp Travel Alarm	G850	BU	Inlet Air Heater
322	GY	Warning Horn (Forward)	G854	PK	Injection Actuation Press Cont Valve
326	RD	Key Sw 'C' Term.	G855	PU	Injection Actuation Press Cont Valve Common
397	OR	Hood Raise Motor	G856	WH	TDC Probe +
398	BU	Hood Raise Motor	G857	YL	TDC Probe -
A300	GN	Hood Raise Relay Coil	J807	BK	Transmission Clutch 4 5 6 Return
A301	WH	Hood Raise Relay Coil	J808	BK	Transmission Clutch 1 3 Return
A307	GY	Throttle Position	J809	BK	Transmission Clutch 2 Return
Monitoring Circuits			J813	BK	Implement Solenoid Control Return
403	GN	Alternator (R) Term.	J814	BK	Implement Solenoid Control Return
416	OR	Supplemental Steering Sw	J815	BK	Implement Solenoid Control Return
417	GY	Primary Steering Sw	J843	BK	Turbo Inlet Pressure Sensor Return
419	YL	Parking Brake Sw	J844	GY	Turbo Inlet Pressure Sensor +5v
426	BR	Power Train Oil Filter	T858	GY	Injector 1&2 Return
430	BU	Air Filter	T859	WH	Injector 3&4 Return
432	PK	Brake Press. (Oil)	T860	OR	Injector 5&6 Return
439	YL	Lamp Indicator	900	PU	Xmsn Shift Sol No. 5
442	GY	Hyd System Temp Gage	901	WH	Xmsn Shift Sol No. 6
443	YL	Power Train Temp Gage	944	OR	Cat Data Link +
447	PK	Fuel Level Gage	945	BR	Cat Data Link -
450	YL	Tach Sender (+)	964	BU	Fork Position Select
453	PK	Supplemental Steering Fault Lamp	976	OR	Ride Cont Solenoid 1
484	YL	Primary Steering Lamp	987	WH	Diverter Sol
E455	BR	Hydraulic Oil Filter	994	GY	Oil Pressure (Filtered)
G485	BU	Front Brake Temperature	995	BU	Coolant Temperature
G486	GN	Rear Brake Temperature	A958	WH	Park Brake Sol

WIRE DESCRIPTION

Volume 1 of 2 - CHASSIS Page 2 of 2



Wire Number	Wire Color	Description	Wire Number	Wire Color	Description
Accessory Circuits			A982	BR	Eng Throttle Control
506	PU	Washer - Front	C967	BU	Inlet Air Temperature
507	WH	Washer - Rear	C987	RD	AIH Relay
513	OR	A/C Compressor/Refrigerant Pressure Sw	C991	PK	Fuel Filter Monitor
521	YL	A/C Sw to Refrigerant Sw	E900	WH	Trans Output Spd +
522	WH	A/C Clutch to Thermostat Sw	E901	GN	Trans Output Spd -
C529	GY	Lift Press Sensor	E906	OR	Trans Output Spd Q+
C530	BU	Lift Position Sensor	E907	GY	Trans Output Spd Q-
Lighting Circuits			E908	BR	Trans Input Spd +
604	OR	Stop Lamp	E909	WH	Trans Input Spd -
605	YL	Turn Lamp - Left	E919	YL	Aux Lower Proportional Sol
606	GY	Turn Lamp - Right	E920	BR	Aux Lift Proportional Sol
611	PU	Head Lamp Hi	E921	PK	Rackback Proportional Sol
614	PU	Park/tail/dash/lamp	E922	GN	Dump Proportional Solenoid
617	BR	Tail/position Lamp - Left (road Pkg)/width	E963	BK	Engine Speed/Timing A-
619	GN	Head Lamp Low	E964	WH	Engine Speed/Timing A+
A693	OR	Fuel Priming Pump Sw to Fuel Priming Pump	E965	BU	Engine Speed/Timing B-
Control Circuits			E966	YL	Engine Speed/Timing B+
727	GN	Supplemental Steering Motor Relay	K927	BU	Pilot Hydraulic Supply Solenoid Return
728	BU	Supplemental Steering Control Sw	K977	PK	Trans Oil Temp Sensor
751	GN	Xmsn Shift Sol No. 1 Or 3	L983	WH	Injector 1&2 Return
752	YL	Xmsn Shift Sol No. 2	L984	OR	Injector 3&4 Return
754	BU	Xmsn Shift Sol No. 3 Or 1	L985	YL	Injector 5&6 Return
755	OR	Xmsn Shift Sol No. 4 Or 5	N939	GN	Ride Control Solenoid 2
762	YL	Bucket Positioner Sol Sw	P945	OR	Anti Drift Sol- Stick
779	WH	Quick Coupler Engage Sol	P946	BR	Anti Drift Sol- Boom
A701	GY	Injector Solenoid 1	P976	BR	Quick Coupler Sw to Quick Coupler Solenoid
A702	PU	Injector Solenoid 2	P990	BR	Start Relay Control Return
A703	BR	Injector Solenoid 3	T957	PU	Injector Solenoid 1
A704	GN	Injector Solenoid 4	T958	YL	Injector Solenoid 2
A705	BU	Injector Solenoid 5	T959	BR	Injector Solenoid 3
A706	GY	Injector Solenoid 6	T960	BU	Injector Solenoid 4
A751	YL	Not Used	T961	GN	Injector Solenoid 5
E748	BK	Start Aid Solenoid Return	T962	WH	Injector Solenoid 6
F713	OR	Left Turbo Inlet Press	X918	PU	Gnd Level Shutdown (N/O)
F762	GY	Start Aid Solenoid Drive from Engine ECM	X919	WH	Gnd Level Shutdown (N/C)

WIRE DESCRIPTION

Volume 2 of 2 - CAB

Page 1 of 2



Wire Description					
Wire Number	Wire Color	Description	Wire Number	Wire Color	Description
Power Circuits			Lighting Circuits Continued		
102	RD	Hd Lmp	619	GN	Head Lamp Low
104	YL	MSS / Product Link	633	BU	Attach Lighting Ckt
105	RD	Key Sw	646	OR	Light Sw To Front Flood Relay
106	WH	Tilt/Lift Position Sensors	647	GN	Light Sw To Rear Flood Relay
108	BU	Air Seat	651	PK	Flood Lamp Rear
110	RD	Engine ECM	661	GN	Tachometer Lamp
112	PU	Main Power Rly Output	662	YL	Speedometer Lamp
113	OR	Opr Mon Panel Vmis B+ Switched	663	GY	Gage Lamps
114	RD	Warning Horn (forward)	691	GY	Warning Lights To Breaker
115	PK	Voltage Converters / Radio	A629	BU	Front Rops Hid Flood Attachment
118	GY	Front/Rear Wiper/Washer	Control Circuits		
120	RD	Voltage Converter Memory	720	PU	Xmsn Brake Sw
121	RD	Back Alarm To Lamp	727	GN	Supplemental Steering Motor Relay
122	RD	Dome Lamps	728	BU	Supplemental Steering Cont Sw
124	GN	AC	751	GN	Xmsn Shift Sol No. 1 Or 3
125	RD	Product Link ECM/Radio	752	YL	Xmsn Shift Sol No. 2
126	PK	Xmsn Ctrl	754	BU	Xmsn Shift Sol No. 3 Or 1
127	OR	Front Cab Flood Lamps	755	OR	Xmsn Shift Sol No. 4 Or 5
130	RD	Stop Lamps	762	YL	Bucket Positioner Sol Sw
131	BR	Flasher / Front/Rear Flood Relays	E701	PK	Auto Ride Control Sw
133	RD	LH/RH Dash Indicator Panels	E707	GN	CMS Display +v
134	YL	Rear Cab Flood Lamps	E708	PK	CMS Display Clock
135	BU	Converter 12 Volt Switched Out	E735	PU	CMS Tack/Serv Mtr/Odometer Select
136	GN	Supplemental Steering	E746	GN	Downshift Sw (N.O.)
138	GN	Auto Lube Pump To PCS	G746	WH	Xmsn Cont Torque Limit
139	RD	LH Tail / Clearance Lamps	G750	BU	Xmsn Cont Fwd Sw To Gnd
141	PK	Beacon / Heated Mirrors	G755	GY	Xmsn Cont Rev Sw To Gnd
142	BU	Converter 12 Volt Switched Out	G760	WH	Xmsn Cont Speed 2 Sw To Gnd
147	RD	ECAP / Center Dash Indicator Panel	G761	YL	Xmsn Cont Speed 3 Sw To Gnd
148	RD	Voltage Converter Memory	G762	BR	Xmsn Cont Speed 4 Sw To Gnd
150	OR	Bat (+)	G763	BU	Xmsn Cont Neut Sw To Gnd
151	GN	Axle Oil Cooler Clutch	G764	PK	Xmsn Cont Park Brake Lever Sw To Gnd
164	WH	Hydro Ctrl Wtl Powertrain Ctrl	G766	GN	Impl Cont Sw To Gnd N.O.
168	GN	Quick Coupler	G767	WH	Impl Cont Sw To Gnd N.C.
170	RD	Transmission ECM	G768	GN	Xmsn Cont Speed 1 Sw To Gnd
174	RD	Unswitched Bus Power	G787	GN	Xmsn Cont Remote Fwd Sw To Gnd
199	RD	Hood Actuator	G788	YL	Xmsn Cont Remote Rev Sw To Gnd
A105	OR	8 Volt Sensor Supply+	H702	PU	Impl Cont Reversing Fan Sw (N.O.)
Ground Circuits			H703	YL	Impl Cont Reversing Fan Sw (N.C.)
200	BK	Main Chassis	H708	OR	Impl Cont Kickout Sw 1
201	BK	Operator Monitor Return	H709	BU	Impl Cont Kickout Sw 2
202	BK	Xmsn Ctrl	H710	PK	Impl Cont Lift Lever Position
210	BK	Converter Output (24/12 Volt)	H711	GN	Impl Cont Tilt Lever Position
250	BK	Payload Mon - Customer Gnd	H713	PK	Impl Cont Lift Proportional Sol
251	BK	Payload Mon - System Gnd	H714	OR	Impl Cont Lower Proportional Sol
290	BK	CMS Service	H717	BR	Impl Cont Pilot Press Sol
291	BK	CMS Clear	H718	GY	Impl Cont Tilt Cyl Position
A272	BK	Implement Ctrl B	H722	GN	Xmsn Cont L. Brake Pedal Position Sens
A273	BK	Transmission Ctrl B-	H728	GN	CCS Auto 3
C216	BK	Implement Return	H729	WH	CCS Auto 2
Basic Machine Circuits			H730	BR	CCS Auto 1-4
306	GN	Starter Relay Coil to Transmission Control	H795	PK	Throttle Sensor Common
307	OR	Key Sw to Transmission Control	J764	BR	Transmission Switch/Sensor Return #1
308	YL	Main Power Relay Coil	P739	BU	Axle Cooler Clutch
320	OR	Horn Relay Coil To Sw	Y794	OR	Expanded Can Data Link +
321	BR	Backup Alarm Lamp Travel Alarm	Y795	GN	Expanded Can Data Link -
322	GY	Warning Horn (forward)	818	BR	Serial Data (transmit)
326	PU	Key Sw 'C' Term.	819	GY	Serial Data (receive)
A307	GY	Throttle Position	G848	GN	Led Driver 2
Monitoring Circuits			G850	BU	Inlet Air Heater
403	GN	Alternator (R) Term.	J807	BK	Proportional Return (1-3)
410	WH	Opr Mon Action Alarm	J808	BK	Proportional Return (4/Rev)
411	PK	Opr Mon Master	J809	BK	Proportional Return (Forward)
413	BR	Opr Mon Fuel Press.	J813	BK	Implement Proportional Return
416	OR	Supplemental Steering Sw	J814	BK	Implement Proportional Return
417	GY	Primary Steering Sw	J815	BK	Ride Control Solenoids Proportional Return
419	YL	Opr Mon Parking Brake	J887	PU	Axle Cooler Relay
426	BR	Opr Mon Power Train Oil Filter	T852	GY	Auto Dig Mode Sw. Pos #1
430	BU	Opr Mon Air Filter	T853	OR	Auto Dig Mode Sw. Pos #2
432	PK	Opr Mon Brake Press. (oil)	T854	YL	Auto Dig Mode Sw. Pos #3
436	OR	Opr Mon Power Train Oil Filter Jumper	T855	BU	Auto Dig Mode Sw. Pos #4
439	YL	Lamp Indicator	T856	WH	Auto Dig Mode Select Sw. Pos #1
442	GY	Hyd System Temp Gage	T857	GN	Auto Dig Mode Select Sw. Pos #2
443	YL	Power Train Temp Gage	T858	GY	Auto Dig Kickout Set Sw. (N.O.)
447	PK	Fuel Level Gage	T859	WH	Auto Dig Kickout Set Sw. (N.C.)
450	YL	Tach Sender (+)	T860	OR	Auto Dig Trigger Sw. (N.O.)
453	PK	Supplemental Steering Fault Lamp	T861	YL	Auto Dig Trigger Sw. (N.C.)
484	YL	Primary Steering Lamp	T862	BU	Auto Dig Auto Trigger Indicator
C413	YL	CMS Display Data	T863	PU	Auto Dig Record Mode Indicator
C414	BU	CMS Display Load	T864	BR	Auto Dig Operator Trigger Indicator
E416	PU	Lift Cyl Press Sensor	T866	YL	Dump Detent
E455	BR	Hydraulic Oil Filter	T869	WH	Fine Modulation Sw 1
G479	WH	Pre-lube Indicator	T870	BR	Fine Modulation Sw 2
G480	GN	Fuel Level Low Indicator	900	PU	Xmsn Shift Sol No. 5 Or 4
G485	BU	Opr Mon Front Brake Temperature	901	WH	Xmsn Shift Sol No. 6
G486	GN	Opr Mon Rear Brake Temperature	910	YL	Xmsn Neutizer Override Indicator

WIRE DESCRIPTION

Volume 2 of 2 - CAB

Page 2 of 2



Wire Description					
Wire Number	Wire Color	Description	Wire Number	Wire Color	Description
Accessory Circuits			944	OR	Cat Data Link +
500	BR	Wiper - Front (Park)	945	BR	Cat Data Link -
501	GN	Wiper - Front (Low)	961	BR	Selector Sw
502	OR	Wiper - Front (Hi)	964	BU	Fork Position Select
503	BR	Wiper - Rear (Park)	973	BR	Autoshift- Auto/Manual Sw 2
504	YL	Wiper - Rear (Low)	976	OR	Ride Cont Solenoid 1
505	BU	Wiper - Rear (Hi)	977	YL	Autoshift- Auto/Manual Sw 1
506	PU	Washer - Front	987	WH	Third Function Diverter Sol
507	WH	Washer - Rear	A958	WH	Park Brake Sol
508	PU	Radio Speaker - Left	A982	BR	Engine Throttle Cont
509	WH	Radio Speaker - Left (Common)	E900	WH	Trans Output Spd +
511	BR	Radio Speaker - Right	E901	GN	Trans Output Spd -
512	GN	Radio Speaker - Right (Common)	E906	OR	Trans Output Spd Q+
515	GY	Blower Motor (Hi)	E907	GY	Trans Output Spd Q-
516	GN	Blower Motor (Medium)	E908	BR	Trans Input Spd +
517	BU	Blower Motor (Low)	E909	WH	Trans Input Spd -
518	OR	Hazard Flasher To Sw	E917	WH	Implement Lockout Sw To Gnd (N.O.)
521	YL	A/C Sw To Refrigerant Sw	E918	GN	Implement Lockout Sw To Gnd (N.C.)
522	WH	A/C Clutch To Thermostat Sw	E919	YL	Aux Lower Proportional Sol
537	GN	Turn Signal Sw To Flasher	E920	BR	Aux Lift Proportional Sol
538	BR	Hazard Indicator	E921	PK	Rackback Proportional Sol
539	BU	Turn Signal Indicator Basic/Right	E922	GN	Dump Proportional Solenoid
540	WH	Turn Signal Indicator Left	E955	OR	PCS Keypad Data
550	GY	Aux Hyd Left- Disconnect To Sw	K927	BU	On/Off Pilot Solenoid Return
567	WH	A/C Sw Jumper	K977	PK	Trans Oil Temp Sensor
592	BU	DC/DC Converter Power Output	N939	GN	Ride Control Solenoid 2
A513	RD	DC/DC Converter Memory Output	N957	PK	Rxd - Comm #1
A523	PU	Temp Potentiometer Pos 1	N959	PK	Rxd - Comm #3
A524	BR	Temp Potentiometer Pos 2	N960	OR	Txd - Comm #1
A525	GN	Temp Potentiometer Pos 3	N963	OR	Txd - Comm #3
A541	PU	Flasher To Indicator Lights	N970	YL	Dtr - Comm #1
C529	GY	Lift Press. Sensor	N973	BR	Dcd - Comm #1
C530	BU	Lift Position Sensor	N979	GN	Signal Gnd - Comm #1
C542	GN	Heated Mirror Power	N981	GN	Signal Gnd - Comm #3
C543	GY	Aux Heater Blower	P910	BR	Secondary Steering Test Sw Input
C583	GN	+24v Relay To A/C Control Module	P915	PK	Xmsn Neutral Indicator
F523	PU	Temp Potentiometer Pos 1	P916	OR	Xmsn Neutral Switch
F524	BR	Temp Potentiometer Pos 2	P945	OR	Anti Drift Sol- Stick
F525	GN	Temp Potentiometer Pos 3	P946	BR	Anti Drift Sol- Boom
Lighting Circuits			P976	BR	Quick Coupler Sw To Low Pressure Sol
603	PK	Rotary Beacon	P990	BR	Start Relay Ctrl Return
604	OR	Stop Lamp	T901	YL	MSS Exciter Coil In
605	YL	Turn Lamp - Left	T902	PK	MSS Exciter Coil Out
606	GY	Turn Lamp - Right	T969	YL	Third Function Control Flow Switch
608	GN	Flood Lamp - Rear	T970	GY	Third Function Control Flow Switch
610	OR	Head Lamp Basic	X972	GN	Part Throttle Auto Shift Position 1
611	PU	Head Lamp Hi	X973	BU	Part Throttle Auto Shift Position 2
614	PU	Park/Tail/Dash/Lamp	X974	BR	Part Throttle Auto Shift Position 3
615	YL	Cab Flood Lamp/Rops	X998	BR	Digital Sensor Return
617	BR	Tail/position Lamp - Left (Road Pkg)/Width			

SPECIFICATIONS AND RELATED MANUALS

Volume 1 of 2 - CHASSIS



Related Electrical Service Manuals	
Title	Form Number
Cross Reference for Electrical Connectors:	REHS0970
Alternator: 177-9953 197-8820	SENR4130
Electric Starting Motor: 207-1517	SENR3581
Engine Control:	REN9319

Off Machine Switch Specification				
Part No.	Function	Actuate	Deactuate	Contact Position
114-5333	A/C (High / Low) Pressure	275 to 1750 kPa ¹ (39.9 to 253.8 psi)	-	Normally Open ²
117-7773	Hydraulic Filter Bypass Pressure	138 ± 28 kPa (20 ± 4 psi)	69 ± 20 kPa (12.9 ± 2.9 psi)	Normally Closed
174-4312	Park Brake Pressure	8270 kPa MAX (1200 psi MAX)	8890 ± 345 kPa (1000 ± 50 psi)	A-B, Normally Open A-C, Normally Closed
175-3244	Brake Oil Pressure	10700 kPa MAX (1560 psi MAX)	8960 ± 537 kPa (1300 ± 79 psi)	A-B, Normally Open A-C, Normally Closed
230-5771	Primary Steering Pressure Secondary Steering Pressure	1200 kPa MAX (174.0 psi MAX)	700 ± 100 kPa (102 ± 14.5 psi)	A-B Normally Open A-C Normally Closed
258-0883	Fuel Differential Pressure	110.3 ± 13.8 kPa (16 ± 2 psi)	69 kPa MIN (10 psi MIN)	Normally Closed

¹ With increasing pressure the closed condition can be maintained up to 2800 kpa (405 psi), with decreasing pressure the closed condition can be maintained down to 170 kpa (25psi).

² Contact position at the contacts of the harness connector.

Resistor, Sender and Solenoid Specifications		
Part No.	Component Description	Resistance (Ohms) ¹
134-2540	Resistor: CAN Data Link	120
145-7028	Sender: T/C Temperature	1250
148-2350	Solenoid: Variable Speed Fan	5.0 ± 0.3
163-0872	Solenoid: A/C Compressor Clutch	17.6±0.6
183-7595	Solenoid: Axle Cooler Clutch	5.0 ± 0.3
225-0300	Solenoid: Pilot Hydraulic Supply	38.12 ± 1.9
241-5895	Solenoid: Auto/Reverse Fan	35 ± 0.5
245-4659	Sender: Fuel Level	Empty: 240 - 250 Full: 28 - 33
244-3114	Solenoid: Transmission Clutch	8.7 ± 0.4
239-1134	Solenoid: Start Aid	20.0
262-5265	Solenoid: Dump Anti-Drift Lower Anti-Drift Ride Control 3	33.8
285-5730	Solenoid: Aux 3rd Function Forward Aux 3rd Function Rearward Dump Prop Racback Prop Raise Prop	5.0 ± 0.3

¹ At room temperature unless otherwise noted.

SPECIFICATIONS AND RELATED MANUALS

Volume 2 of 2 - CAB



Related Electrical Service Manuals	
Title	Form Number
Cross Reference for Electrical Connectors:	REHS0970
Machine Security System:	REN2462
Product Link Radio:	REN7911
Power Train Control:	REN8846
Implement Control:	REN8858
Caterpillar Monitoring System:	SENR1394
Payload Control System:	REN6293

Off Machine Switch Specification				
Part No.	Function	Actuate	Deactuate	Contact Position
3E-5464	A/C Thermostat	-1.1 ± 0.8°C (30 ± 1.4°F)	2.2 ± 0.8°C (36 ± 1.4°F)	Normally Closed

Resistor, Sender and Solenoid Specifications		
Part No.	Component Description	Resistance (Ohms) ¹
9G-1950	Resistor: Blower Motor Speed	Overall: 2.0 ± 0.1 Tap 1.0 ± .05
134-2540	Resistor: CAN	120

¹ At room temperature unless otherwise noted.

HARNESS and WIRE

Electrical Schematic Symbols



Symbols

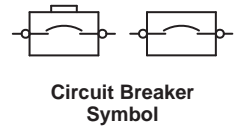
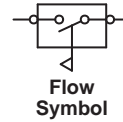
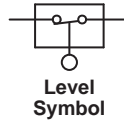
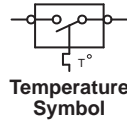
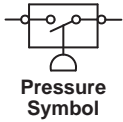

Symbols and Definitions



Fuse: A component in an electrical circuit that will open the circuit if too much current flows through it.

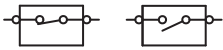

Switch (Normally Open): A switch that will close at a specified point (temp, press, etc.). The circle indicates that the component has screw terminals and a wire can be disconnected from it.

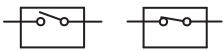

Switch (Normally Closed): A switch that will open at a specified point (temp, press, etc.). No circle indicates that the wire cannot be disconnected from the component.

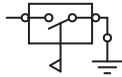

Ground (Wired): This indicates that the component is connected to a grounded wire. The grounded wire is fastened to the machine.

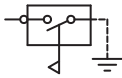

Ground (Case): This indicates that the component does not have a wire connected to ground. It is grounded by being fastened to the machine.



Reed Switch: A switch whose contacts are controlled by a magnet. A magnet closes the contacts of a normally open reed switch; it opens the contacts of a normally closed reed switch.

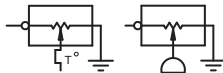

Sender: A component that is used with a temperature or pressure gauge. The sender measures the temperature or pressure. Its resistance changes to give an indication to the gauge of the temperature or pressure.

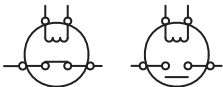

Relay (Magnetic Switch): A relay is an electrical component that is activated by electricity. It has a coil that makes an electromagnet when current flows through it. The electromagnet can open or close the switch part of the relay.

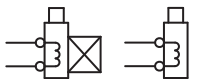

Solenoid: A solenoid is an electrical component that is activated by electricity. It has a coil that makes an electromagnet when current flows through it. The electromagnet can open or close a valve or move a piece of metal that can do work.

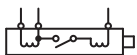

Magnetic Latch Solenoid: A magnetic latch solenoid is an electrical component that is activated by electricity and held latched by a permanent magnet. It has two coils (latch and unlatch) that make electromagnet when current flows through them. It also has an internal switch that places the latch coil circuit open at the time the coil latches.

Harness and Wire Symbols

Wire, Cable, or Harness Assembly Identification: Includes Harness Identification Letters and Harness Connector Serialization Codes (see sample).

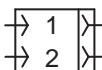
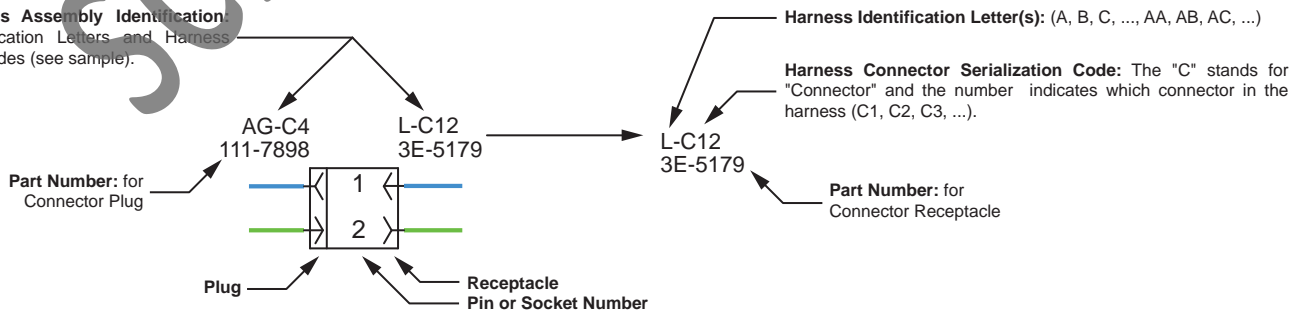

Deutsch connector: Typical representation of a Deutsch connector. The plug contains all sockets and the receptacle contains all pins.

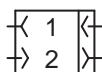

Sure-Seal connector: Typical representation of a Sure-Seal connector. The plug and receptacle contain both pins and sockets.

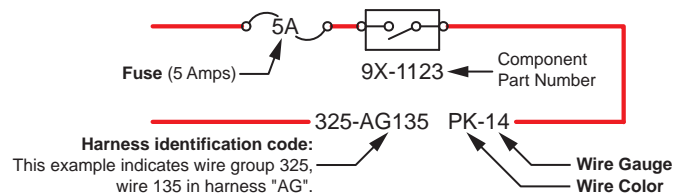

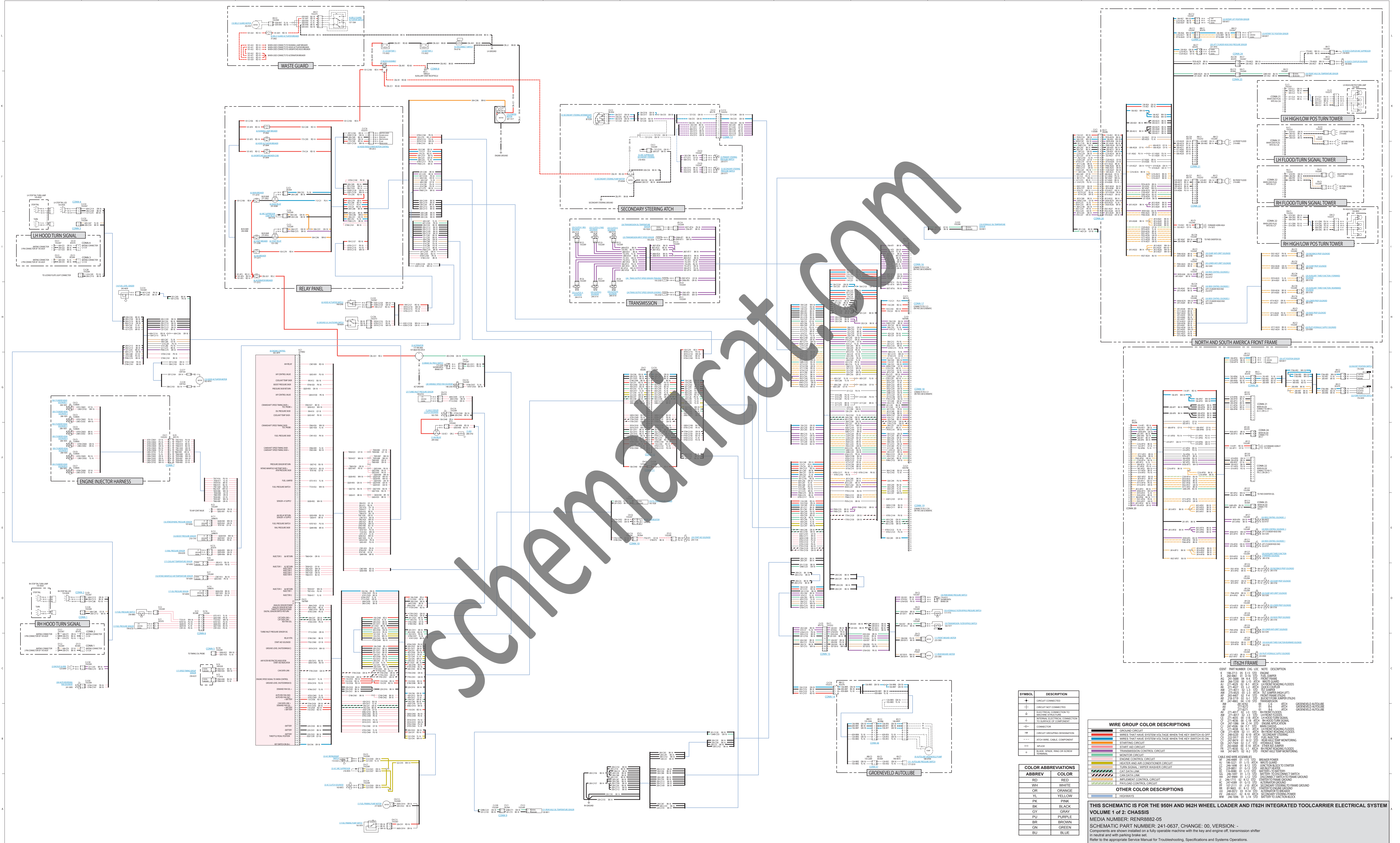

SYMBOL	DESCRIPTION
+	GROUP CONNECTED
+	GROUP NOT CONNECTED
+	ELECTRIC CONNECTION TO
+	MECHANICAL CONNECTION TO
+	TO SOURCE OF CURRENT
+	COMMON
+	GROUP GROUPS DESIGNATION
+	ACTUATOR WIRE CABLE COMPONENT
+	WIRE (BLACK, WHITE OR BROWN TERMINAL)

ABBREV	COLOR
RD	RED
WH	WHITE
OR	ORANGE
YL	YELLOW
PK	PINK
BK	BLACK
GY	GRAY
PJ	PURPLE
BR	BROWN
GN	GREEN
BL	BLUE

WIRE GROUP COLOR DESCRIPTIONS	
[Red line]	GROUND CIRCUIT
[Blue line]	WIRE THAT TRIGGERS SYSTEM VOLTAGE WHEN THE KEY SWITCH IS OFF
[Green line]	WIRE THAT TRIGGERS SYSTEM VOLTAGE WHEN THE KEY SWITCH IS ON
[Yellow line]	START AND CRUISE
[Purple line]	TRANSMISSION CONTROL CIRCUIT
[Pink line]	MONITOR CIRCUIT
[Black line]	ENGINE CONTROL CIRCUIT
[White line]	HEATER AND AIR CONDITIONER CIRCUIT
[Brown line]	TURBO SIGNAL, WIRE HARNESS CIRCUIT
[Orange line]	CAT DATA LINE
[Light Blue line]	CRUISE CONTROL
[Light Green line]	WARRANTY CONTROL CIRCUIT
[Light Purple line]	TRANSMISSION CONTROL CIRCUIT
[Light Yellow line]	MONITOR CIRCUIT

OTHER COLOR DESCRIPTIONS	
[Dashed line]	HYDRAULIC

WIRE NUMBER	COLOR	DESCRIPTION
800	RD	ENGINE
801	WH	WHITE SIGNAL
802	OR	ORANGE SIGNAL
803	YL	YELLOW SIGNAL
804	PK	PINK SIGNAL
805	BK	BLACK SIGNAL
806	GY	GRAY SIGNAL
807	PJ	PURPLE SIGNAL
808	BR	BROWN SIGNAL
809	GN	GREEN SIGNAL
810	BL	BLUE SIGNAL
811	RD	RED SIGNAL
812	WH	WHITE SIGNAL
813	OR	ORANGE SIGNAL
814	YL	YELLOW SIGNAL
815	PK	PINK SIGNAL
816	BK	BLACK SIGNAL
817	GY	GRAY SIGNAL
818	PJ	PURPLE SIGNAL
819	BR	BROWN SIGNAL
820	GN	GREEN SIGNAL
821	BL	BLUE SIGNAL
822	RD	RED SIGNAL
823	WH	WHITE SIGNAL
824	OR	ORANGE SIGNAL
825	YL	YELLOW SIGNAL
826	PK	PINK SIGNAL
827	BK	BLACK SIGNAL
828	GY	GRAY SIGNAL
829	PJ	PURPLE SIGNAL
830	BR	BROWN SIGNAL
831	GN	GREEN SIGNAL
832	BL	BLUE SIGNAL

THIS SCHEMATIC IS FOR THE 960H AND 962H WHEEL LOADER AND IT26H INTEGRATED TOOLCARRIER ELECTRICAL SYSTEM
 VOLUME 1 of 2: CHASSIS
 MEDIA NUMBER: IENR882.05
 SCHEMATIC PART NUMBER: 241-0637, CHANGE: 00, VERSION: -
 Components are shown installed on a fully operable machine with the key and engine off, transmission shifter in neutral and with parking brake set.
 Refer to the appropriate Service Manual for Troubleshooting, Specifications and Systems Operations.

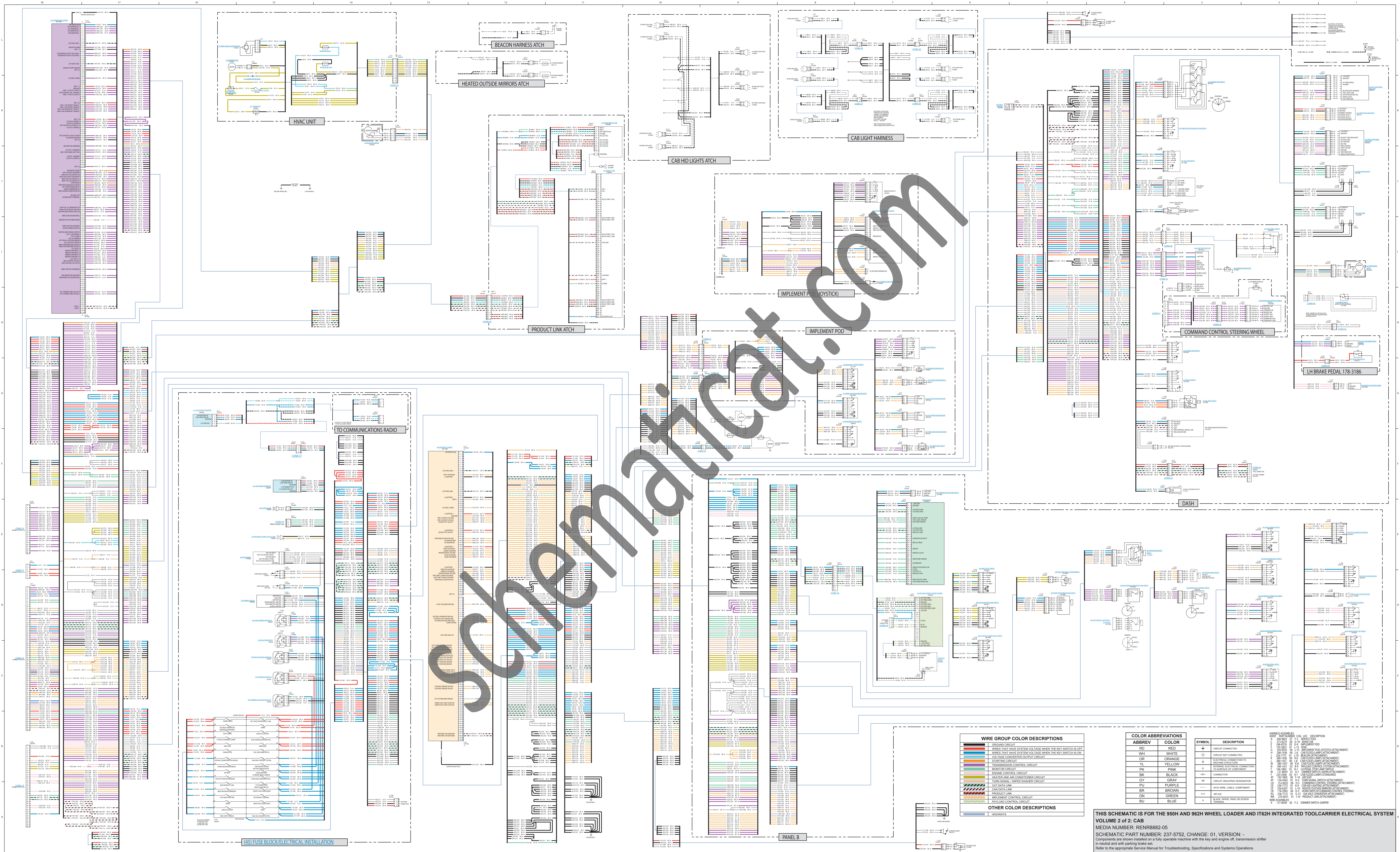

WIRE GROUP COLOR DESCRIPTIONS

GROUND CIRCUIT	RED
WIRING THAT TRIPS SYSTEM VOL TAGS WHEN THE KEY SWITCH IS OFF	ORANGE
WIRING THAT TRIPS SYSTEM VOL TAGS WHEN THE KEY SWITCH IS ON	GREEN
VOL TAGS CONNECTOR OUTPUT CIRCUIT	YELLOW
STARTING CIRCUIT	BLACK
TRANSMISSION CONTROL CIRCUIT	PINK
MONITOR CIRCUIT	GRAY
ENGINE CONTROL CIRCUIT	BLUE
HEATS AND AIR CONDITIONER CIRCUIT	PURPLE
TURN SIGNAL, WIPER, WASHER CIRCUIT	BROWN
CAT DATA LINK	GREEN
LOW VOLTAGE WIRE	RED
PRODUCT LINK	ORANGE
WARRANTY CONTROL CIRCUIT	YELLOW
ALL OTHER COLOR DESCRIPTIONS	BLUE

COLOR ABBREVIATIONS

ABBREV	COLOR	SYMBOL	DESCRIPTION
RED	RED	+	GROUND CONNECTION
WH	WHITE	+	CIRCUIT NOT CONNECTED
OR	ORANGE	+	STARTING CIRCUIT
YEL	YELLOW	+	TRANSMISSION CONTROL CIRCUIT
PK	PINK	+	MONITOR CIRCUIT
BLK	BLACK	+	ENGINE CONTROL CIRCUIT
GRY	GRAY	+	HEATS AND AIR CONDITIONER CIRCUIT
PUR	PURPLE	+	TURN SIGNAL, WIPER, WASHER CIRCUIT
BRO	BROWN	+	CAT DATA LINK
GN	GREEN	+	LOW VOLTAGE WIRE
ORN	ORANGE	+	PRODUCT LINK
BLU	BLUE	+	WARRANTY CONTROL CIRCUIT

OTHER COLOR DESCRIPTIONS

---	GROUND
---	IGNITION
---	STARTING
---	TRANSMISSION
---	MONITOR
---	ENGINE
---	HEATS
---	TURN SIGNAL
---	CAT DATA LINK
---	LOW VOLTAGE WIRE
---	PRODUCT LINK
---	WARRANTY CONTROL
---	ALL OTHERS

THIS SCHEMATIC IS FOR THE 950H AND 962H WHEEL LOADER AND IT62H INTEGRATED TOOLCARRIER ELECTRICAL SYSTEM
VOLUME 2 of 2: CAB
 MEDIA NUMBER: RENR8892-05
 SCHEMATIC PART NUMBER: 237-5752, CHANGE: 01, VERSION: -
 Components are shown installed on a fully operable machine with the key and engine off. Transmission shifter in neutral and with parking brake set.
 Refer to the appropriate Service Manual for Troubleshooting, Specifications and Systems Operations.

MACHINE HARNESS CONNECTOR AND COMPONENT LOCATIONS¹

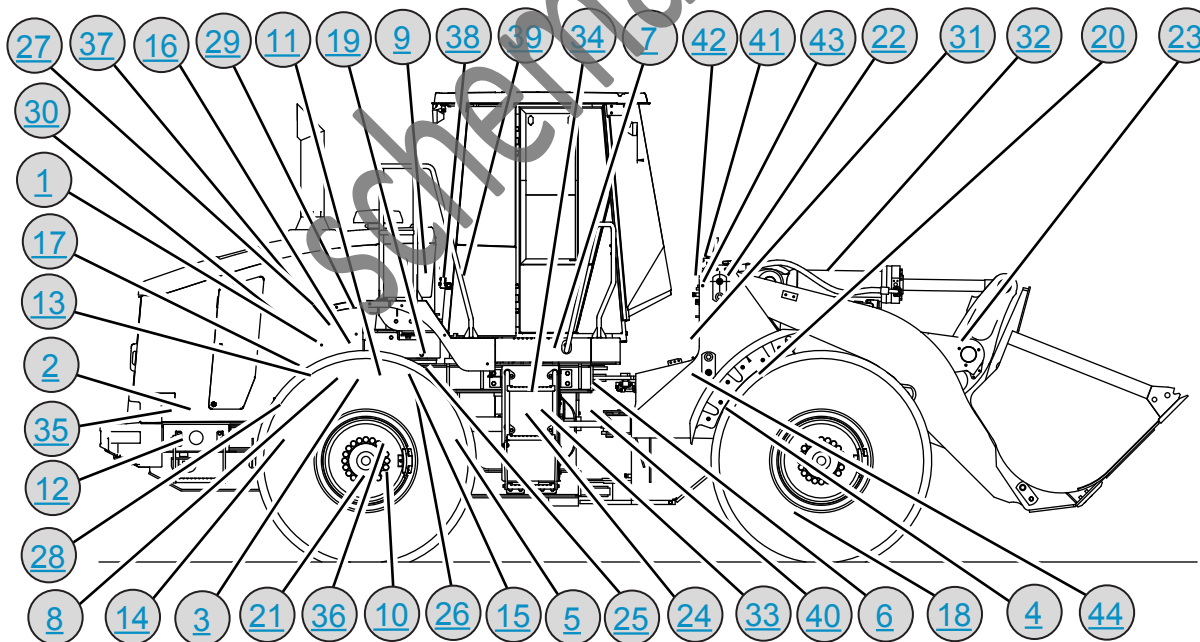
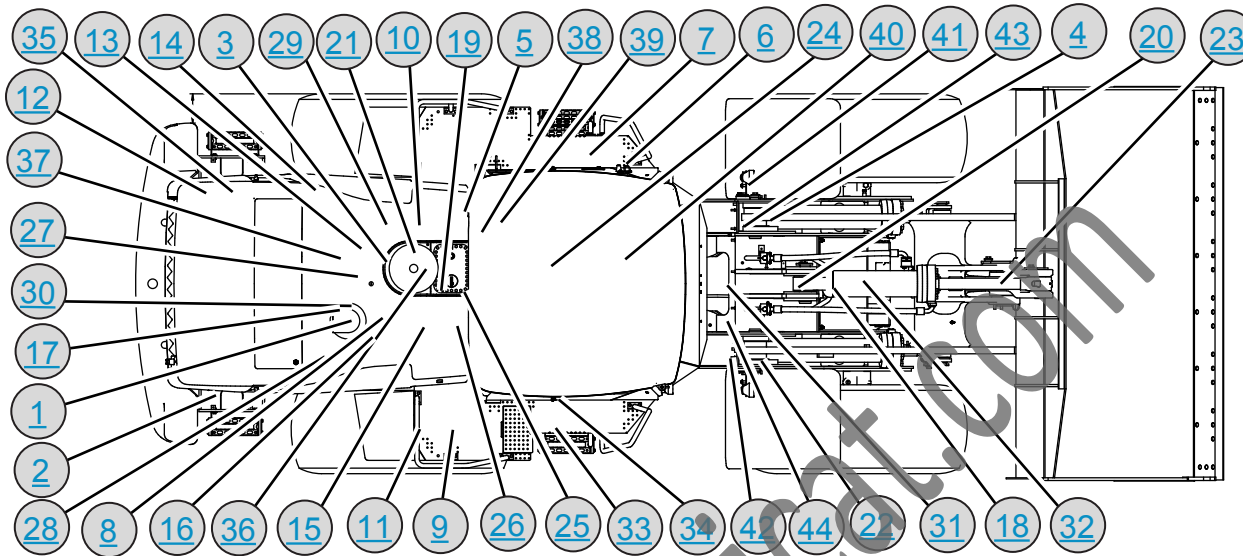

MACHINE HARNESS CONNECTOR AND COMPONENT LOCATIONS 2

