

This document is best viewed at a screen resolution of 1024 X 768.

To set your screen resolution do the following:
RIGHT CLICK on the **DESKTOP**.
 Select **PROPERTIES**.
CLICK the **SETTINGS TAB**.
MOVE THE SLIDER under **SCREEN RESOLUTION** until it shows **1024 X 768**.
CLICK OK to apply the resolution.

The Bookmarks panel will allow you to quickly navigate to points of interest.

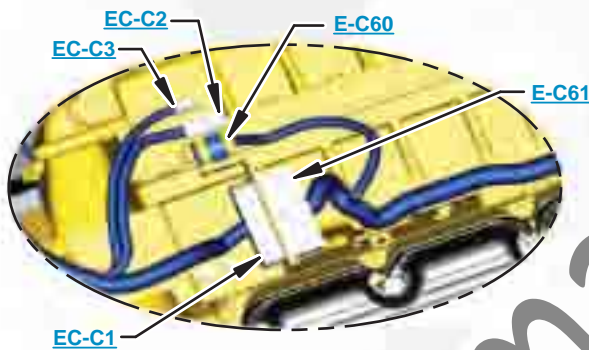

Click on any text that is BLUE and underlined. These are hyperlinks that can be used to navigate the schematic and machine views.

VIEW ALL CALLOUTS

When only one callout is showing on a machine view this button will make all of the callouts visible. This button is located in the top right corner of every machine view page.

HOTKEYS (Keyboard Shortcuts)		
	FUNCTION	KEYS
	Zoom In	"CTRL" / "+"
	Zoom Out	"CTRL" / "-"
	Fit to Page	"CTRL" / "0" (zero)
	Hand Tool	"SPACEBAR" (hold down)
	Find	"CTRL" / "F"



Schematic

950H, 962H, and IT62H Wheel Loader Hydraulic System

950H:

N1A4397-UP
JAD410-UP
M1G2111-UP
K5K2761-UP

962H:

N4A2116-UP
M3G679-UP
K6K517-UP
MAL123-UP

IT62H:

M5G468-UP

COMPONENT LOCATION

Page 1 of 2



Description	Part Number	Machine Location	Schematic Location
Accumulator - Brake	213-8773	1	F-2
Accumulator - Pilot	355-9981	2	F-4
Accumulator - Ride Control	325-7159	3	F-5
Actuator GP - Parking Brake	129-8090	4	F-1
Breather	258-2829	5	A-7
Connector - Orifice	122-2340	6	A-3
Control GP - Foot Brake	271-0263	7	F-2
Cooler - Hyd Oil Standard	244-5427	8	B-8
Attachment	250-8327		
Core AS - Axle Oil Cooler	313-7721	9	C-7
Cylinder GP - Lift (Left)	242-4272	10	F-6
Cylinder GP - Lift (Right)	242-4271	11	F-6
Cylinder GP - Quick Coupler	311-1463	12	D-6
Cylinder GP - Steering	314-9338	13	D-1, D-2
Cylinder GP - Tilt 950 Standard	242-4270	14	F-7
962 Standard	247-0497		
High Lift	245-7491		
Logger	245-7487		
Filter - Axle Oil Cooler	251-6351	15	C-6, F-8
Filter GP - Oil	337-4102	16	A-7
Filter GP - Oil	330-9358	17	B-8
Manifold -Fan Drive and Brake Charge	242-1307	18	E-2
	352-1587		C-8
Motor GP - Fan	246-6152	19	B-8
Pump and Motor GP - Secondary Steering	275-8544	20	A-7
Pump GP - Axle Oil Cooler	215-3013	21	C-6
Pump GP - Fan and Hyd Brake	254-5146	22	B-8
Pump GP - Implement	292-8767	23	B-7
Pump GP - Metering (HMU)	349-6093	24	A-3
Pump GP - Steering	241-9299	25	B-6
Pump GP - Transmission	241-8692	26	B-7
Screen AS - Command Control Steering	154-2883	27	D-2

COMPONENT LOCATION

Page 2 of 2



Description	Part Number	Machine Location	Schematic Location
Screen AS - Implement/Steering Return	9T-9227	28	B-8
Tank GP - Hydraulic	340-5659	29	A-7
Valve - Anti-drift Solenoid	328-4314	30	F-5, F-6, F-7
Valve - Load Sense Relief	346-0475	31	E-7
Valve - Margin Relief	328-0730	32	E-4
Valve - Pressure Reducing Pilot Supply	335-1074	33	E-4
Valve - Pressure Reducing Pilot Supply	114-1267	34	C-2
Valve - Quick Coupler	180-8585	35	D-7
Valve - Ride Control Relief	4T-7581	36	E-5
Valve - Shuttle CCS Pilot	8J-6875	37	C-3
Valve GP - Check Backpressure	353-7179	38	C-5
Valve GP - Brake Control (Parking)	106-1774	39	F-1
Valve GP - Foot Brake	215-3687	40	F-2
Valve GP - Check Anti-Drainback	307-5393	41	B-8
Valve GP - Check Axle Oil-Cooler	130-5202	42	C-6
Valve GP - Check Command Control Steering	111-7775	43	D-3
Valve GP - Check Cooler Bypass	244-1426	44	B-8
Valve GP - Command Control Steering	124-8635	45	D-1
Valve GP - HMU Steering	142-4000	46	B-2
Valve GP - Make-up Lift	234-4869	47	F-6
Valve GP - Main Control Two Function without Ride Control Two Function with Ride Control Three Function without Ride Control Three Function with Ride Control With Ride Control (Logger)	261-4171 261-3682 261-4172 261-3683 256-3643	48	F-4
Valve GP - Manual Lowering	112-1817	49	B-7, D-6, F-7
Valve GP - Manual	8T-6907	50	A-7
Valve GP - Pilot Command Control Steering	147-1790	51	D-3
Valve GP - Relief (Auxiliary)	272-2334	52	F-5
Valve GP - Relief (Tilt)	332-1987	53	F-6
Valve GP - Relief Pump Backup	132-5258	54	C-1
Valve GP - Relief Steering Cylinder Crossover	129-8222	55	D-2
Valve GP - Relief Tilt (Logger)	332-1985	56	F-2
Valve GP - Secondary Steering	141-2597	57	A-6
Valve GP - Shuttle	235-6157	58	E-5
Valve GP - Solenoid	313-7668	59	E-5, E-6, F-5, F-6
Valve GP - Steering Neutralizer (CCS)	321-5283	60	C-2, D-2
Valve GP - Steering Neutralizer (HMU)	296-5662	61	B-3

TAP LOCATION



Tap Number	Description	Schematic Location
G1	Brake Accumulator Pressure	C-8, E-2
G2	Implement Pump Discharge Pressure	E-7
G3	Implement Pump Load Sense Pressure	B-7
G4	Steering Pump Discharge Pressure	B-6
G5	Steering Pump Load Sense Pressure	A-3, D-1
G6	Fan Pump Discharge Pressure	B-7
G7	Fan Pump Load Sense Pressure	B-8
G8	CCS Steering Neutral Pilot Pressure	C-3
G9	CCS Steering Left Pilot Pressure	D-2
G10	CCS Steering Right Pilot Pressure	D-2
G11	CCS Steering Resolved Pilot Pressure	C-3
G12	Case Drain Air Bleed	A-8
B	Front Brake Pressure	F-2
C	Rear Brake Pressure	F-2
SOS	Scheduled Oil Sampling	B-8

FLUID POWER SYMBOLS



BASIC COMPONENT SYMBOLS

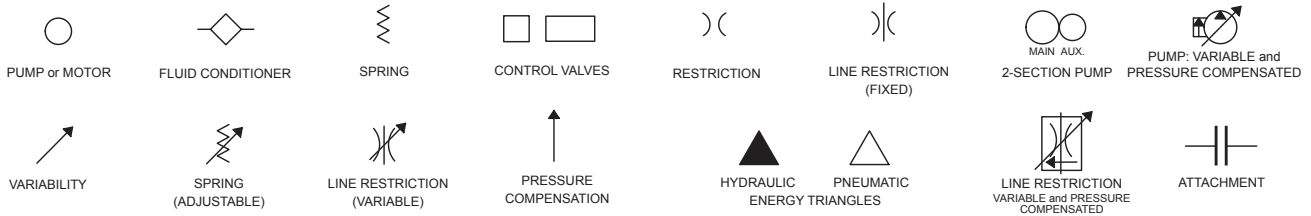

VALVE ENVELOPES

VALVES

VALVE PORTS



CONTROL VALVES

CHECK VALVES

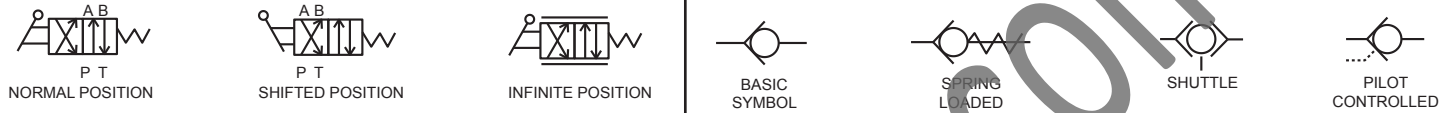

FLUID STORAGE RESERVOIRS



MEASUREMENT

ROTATING SHAFTS



COMBINATION CONTROLS



MANUAL CONTROL SYMBOLS



RELEASED PRESSURE

PILOT CONTROL SYMBOLS

REMOTE SUPPLY PRESSURE



ACCUMULATORS

CROSSING AND JOINING LINES

HYDRAULIC AND PNEUMATIC CYLINDERS

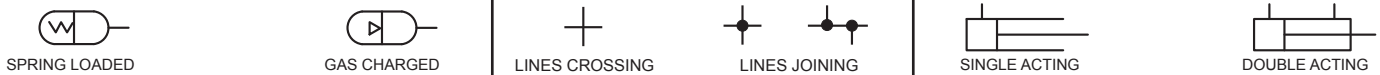

HYDRAULIC PUMPS

HYDRAULIC MOTORS

INTERNAL PASSAGEWAYS

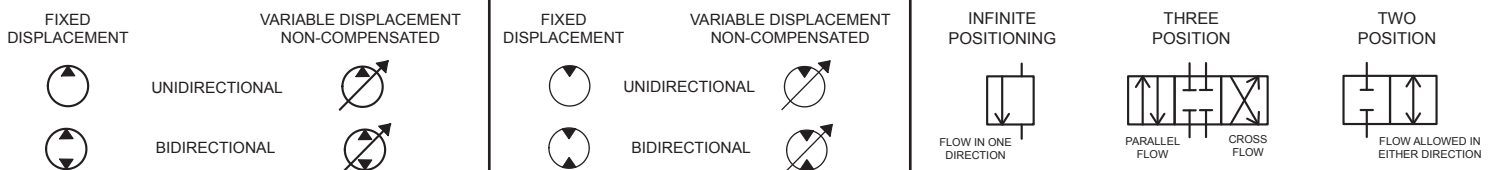

ELECTRICAL SYMBOLS



Hydraulic Symbols (Electrical)



Transducer
(Fluid)

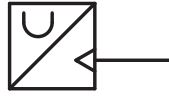

Transducer
(Gas / Air)



Generator



Electric Motor

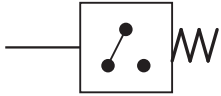

Pressure Switch

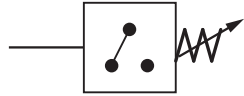

Pressure Switch
(Adjustable)

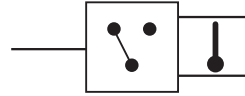

Temperature Switch



Electrical Wire

Electrical Symbols (Electrical)

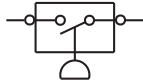

Pressure
Symbol

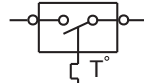

Temperature
Symbol



Level
Symbol

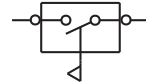

Flow
Symbol

Wire Number Identification Codes

Electrical Schematic Example

Current Standard

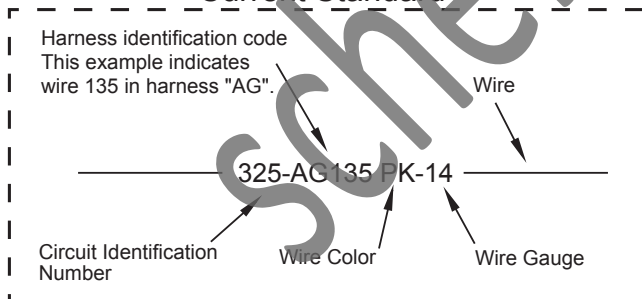

Previous Standard

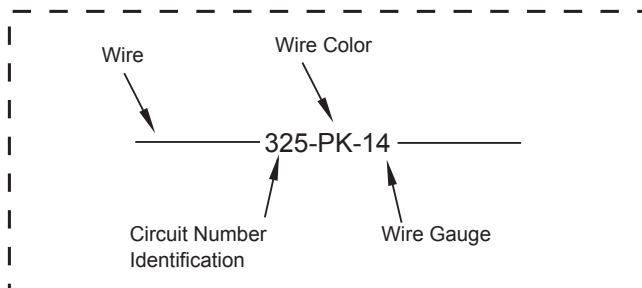

Hydraulic Schematic Example

Current Standard

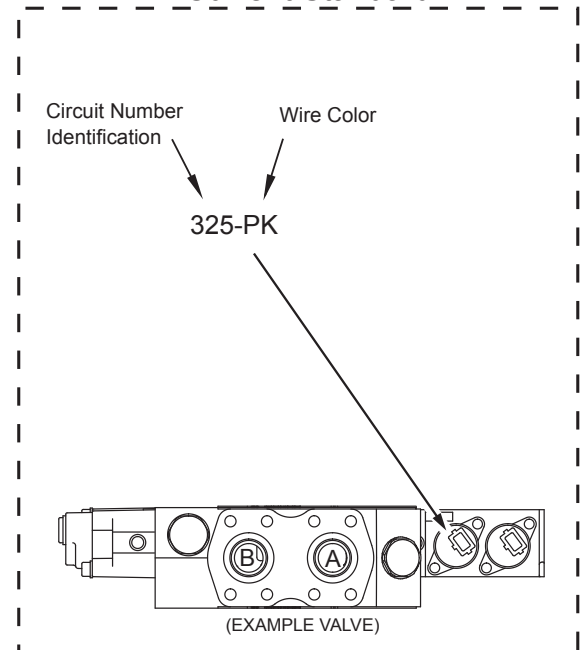

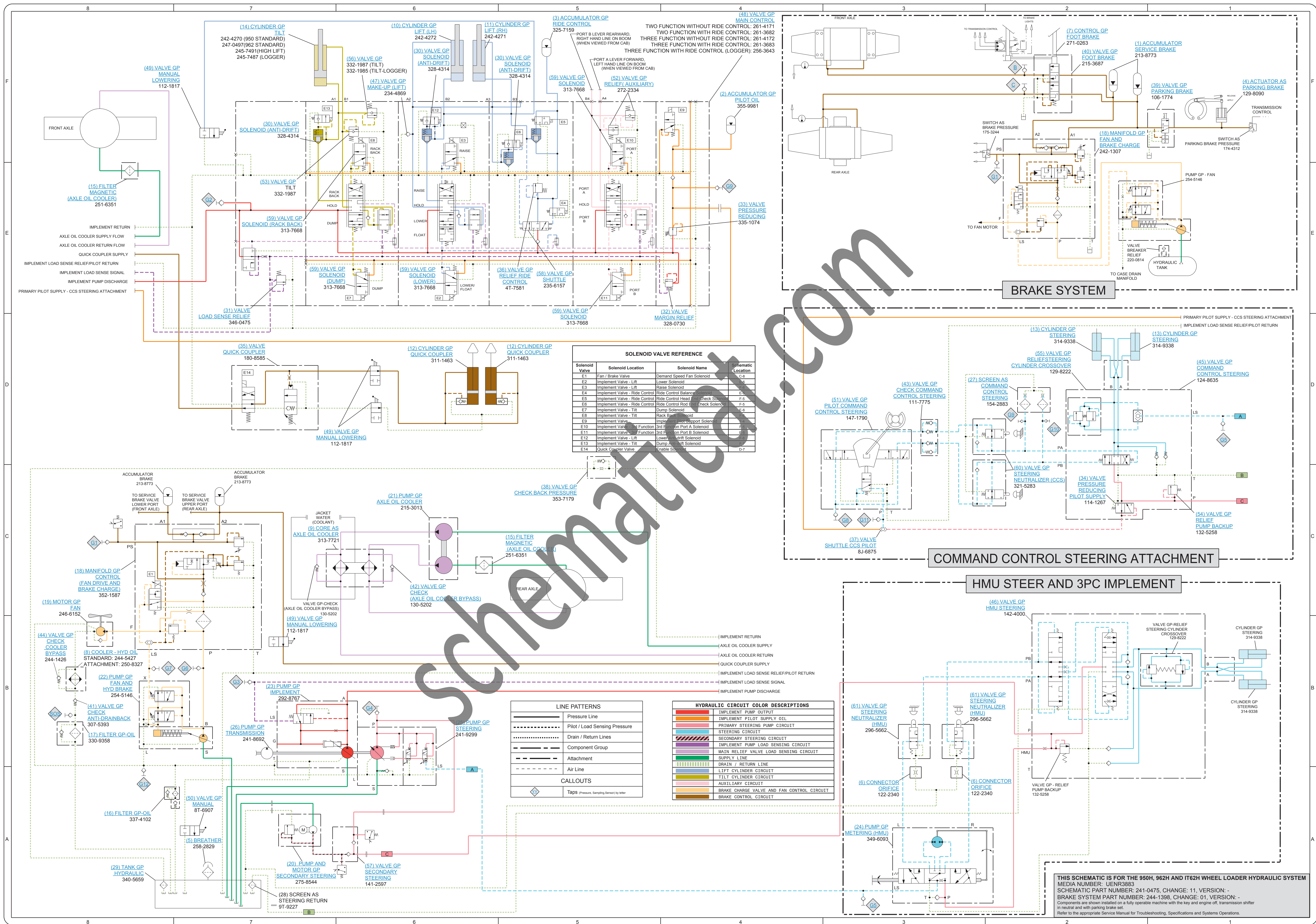

TWO FUNCTION WITHOUT RIDE CONTROL: 261-4171
 TWO FUNCTION WITH RIDE CONTROL: 261-3682
 THREE FUNCTION WITH RIDE CONTROL: 261-4172
 THREE FUNCTION WITH RIDE CONTROL (LOGGER): 256-3643

Solenoid Valve	Solenoid Location	Solenoid Name	Schematic Location
E1	Fan / Brake Valve	Demand Speed Fan Solenoid	C-4
E2	Implement Valve - Lift	Lower Solenoid	C-5
E3	Implement Valve - Lift	Raise Solenoid	E-5
E4	Implement Valve - Ride Control	Ride Control Balance Solenoid	E-6
E5	Implement Valve - Ride Control	Ride Control Head Check Solenoid	F-5
E6	Implement Valve - Ride Control	Ride Control Rod Check Solenoid	F-6
E7	Implement Valve - Tilt	Dump Solenoid	C-6
E8	Implement Valve - Tilt	Rack Back Solenoid	C-7
E9	Implement Valve	Implement Back Support Solenoid	C-8
E10	Implement Valve - 3rd Function	3rd Function Port A Solenoid	C-9
E11	Implement Valve - 3rd Function	3rd Function Port B Solenoid	C-10
E12	Implement Valve - Lift	Lower Drift Solenoid	C-11
E13	Implement Valve - Tilt	Dump Assist Solenoid	C-12
E14	Quick Coupler Valve	Enable Solenoid	D-7

LINE PATTERNS	DESCRIPTION
—	Pressure Line
—	Pilot / Load Sensing Pressure
---	Drain / Return Lines
---	Component Group
---	Attachment
---	Air Line
---	Callouts
---	Tap (Pressure, Sampling Sensor) by letter

HYDRAULIC CIRCUIT COLOR DESCRIPTIONS	
—	IMPLEMENT PUMP OUTPUT
—	IMPLEMENT PILOT SUPPLY OIL
—	PRIMARY STEERING PUMP CIRCUIT
—	STEERING CIRCUIT
—	SECONDARY STEERING CIRCUIT
—	IMPLEMENT PUMP LOAD SENSING CIRCUIT
—	MAIN RELIEF VALVE LOAD SENSING CIRCUIT
—	SUPPLY LINE
—	DRAIN / RETURN LINE
—	LIFT CYLINDER CIRCUIT
—	TILT CYLINDER CIRCUIT
—	AUXILIARY CIRCUIT
—	BRAKE CHARGE VALVE AND FAN CONTROL CIRCUIT
—	BRAKE CONTROL CIRCUIT

THIS SCHEMATIC IS FOR THE 950H, 962H AND IT62H WHEEL LOADER HYDRAULIC SYSTEM
 MEDIA NUMBER: LENDR963
 SCHEMATIC PART NUMBER: 241-0475, CHANGE: 11, VERSION: -
 BRAKE SYSTEM PART NUMBER: 244-1398, CHANGE: 01, VERSION: -
 Components are shown installed on a fully operable machine with the key and engine off, transmission shifter in neutral and with parking brake set.
 Refer to the appropriate Service Manual for Troubleshooting, Specifications and Systems Operations.

MAIN CONTROL VALVE

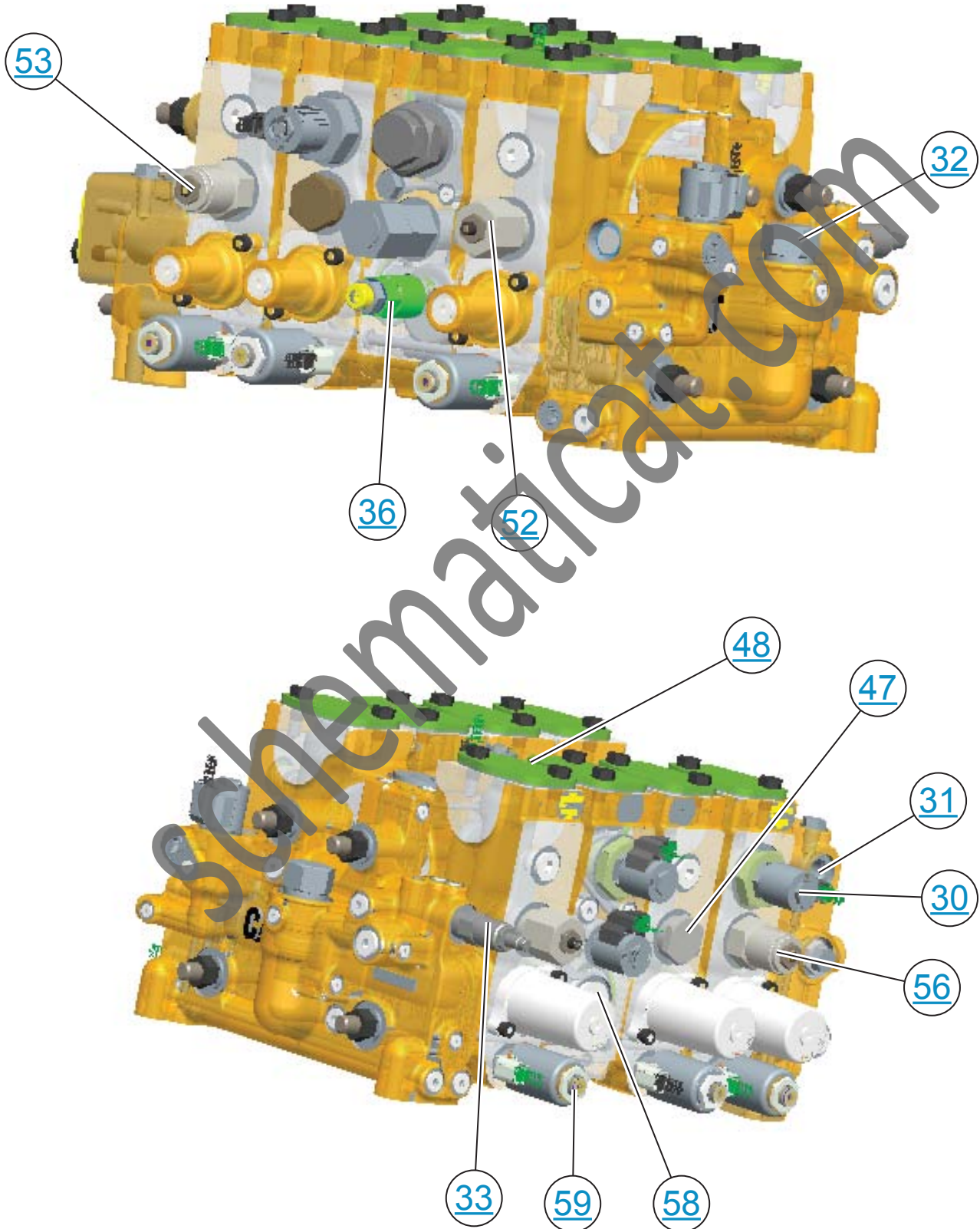

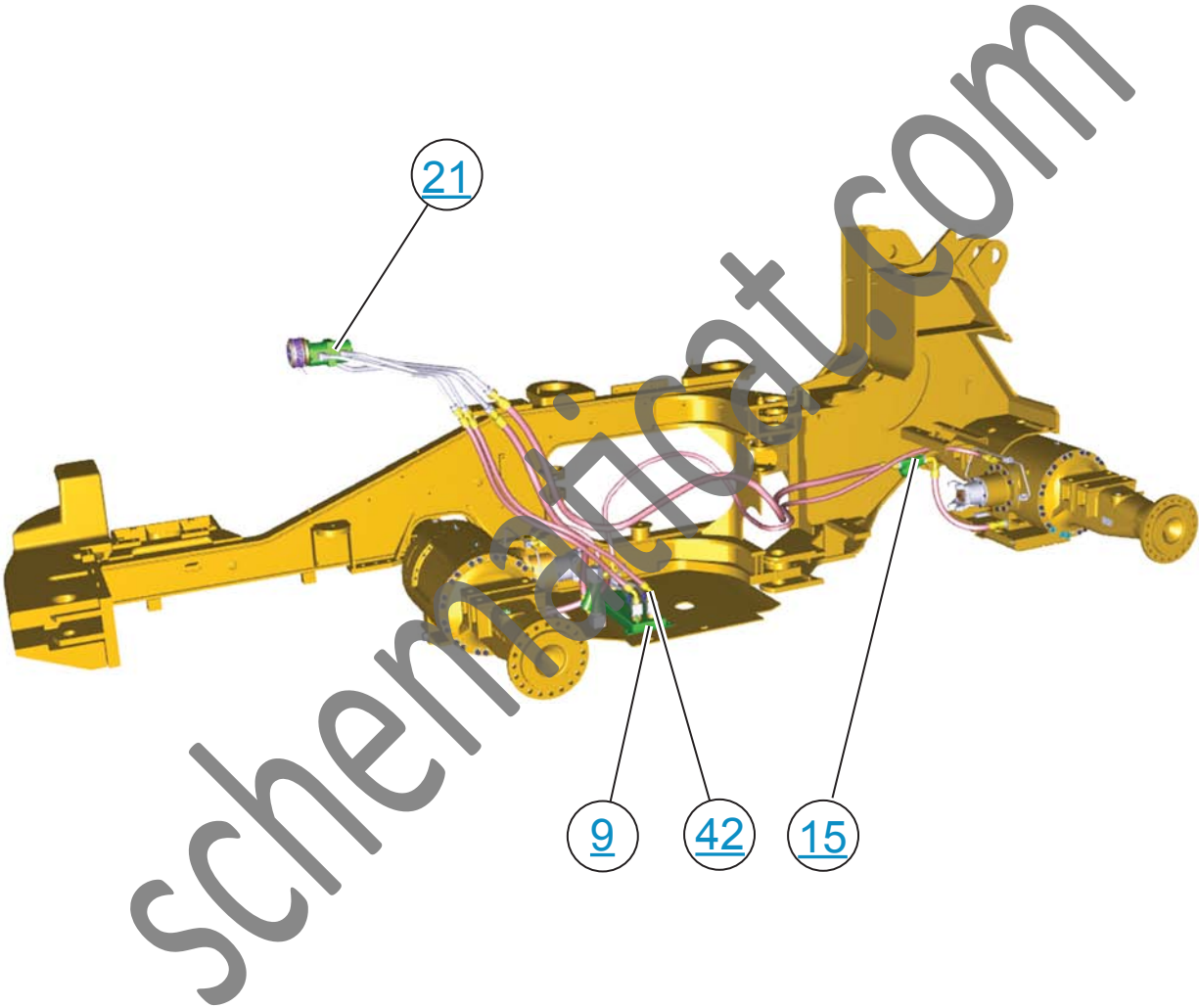

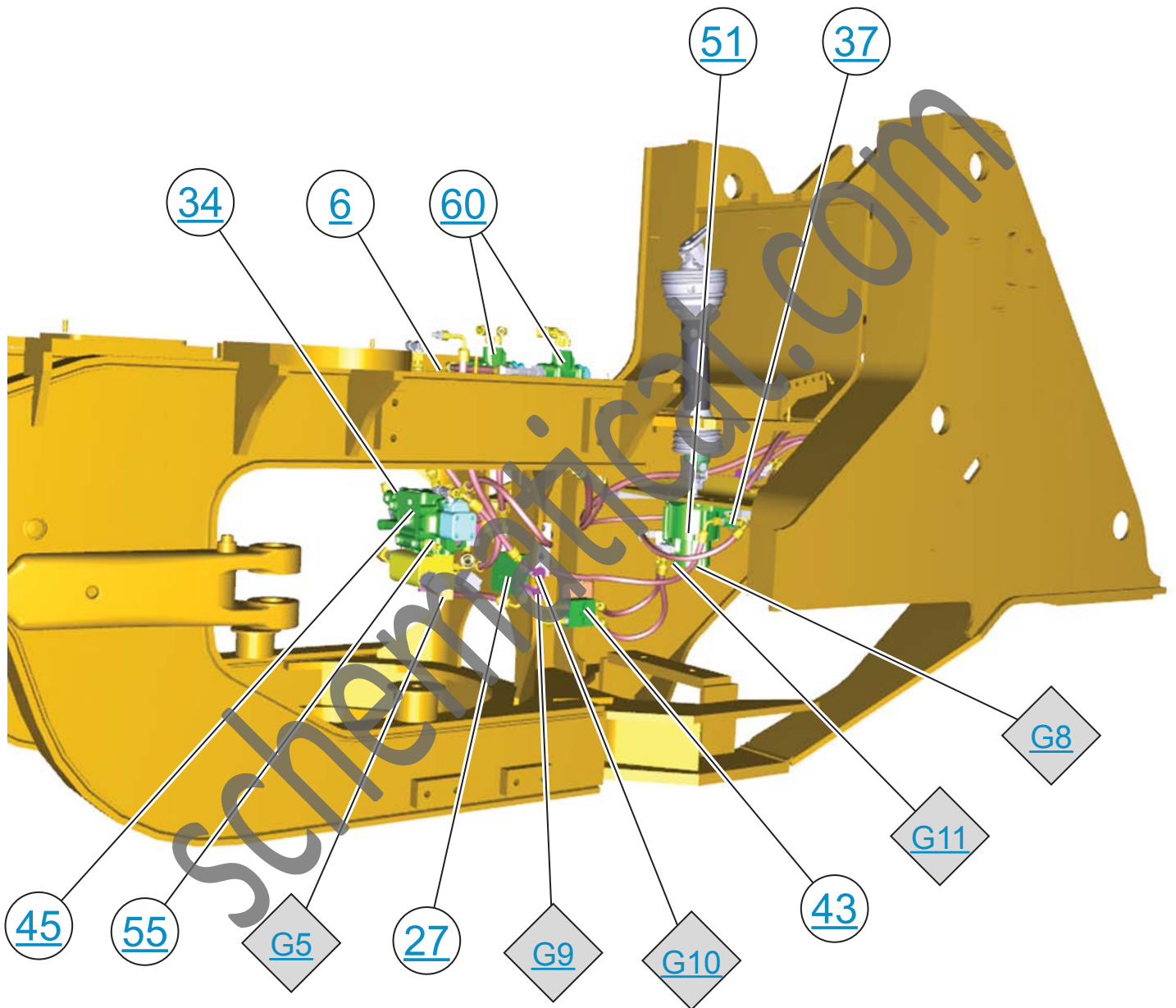

FAN AND BRAKE SYSTEM

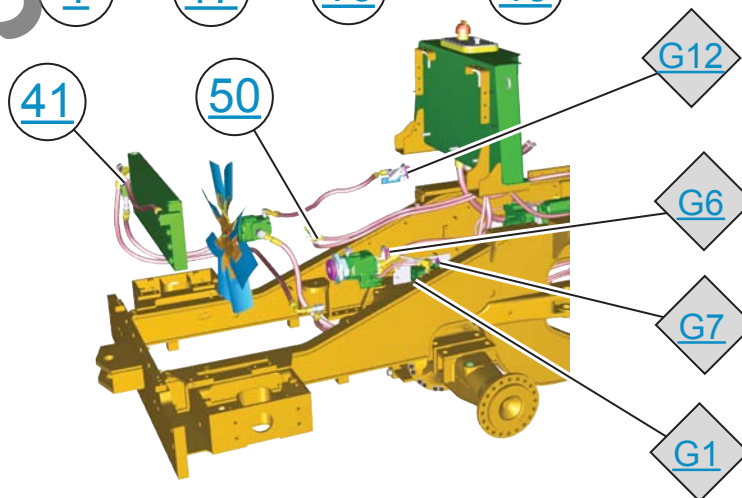
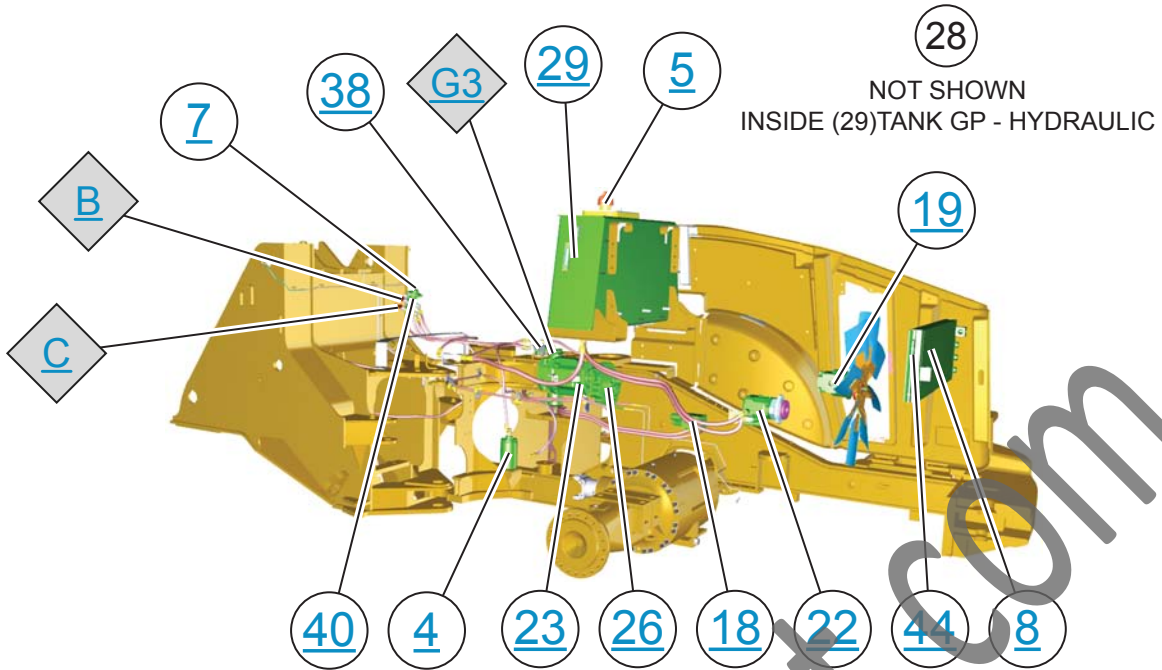

FRONT OF FRAME

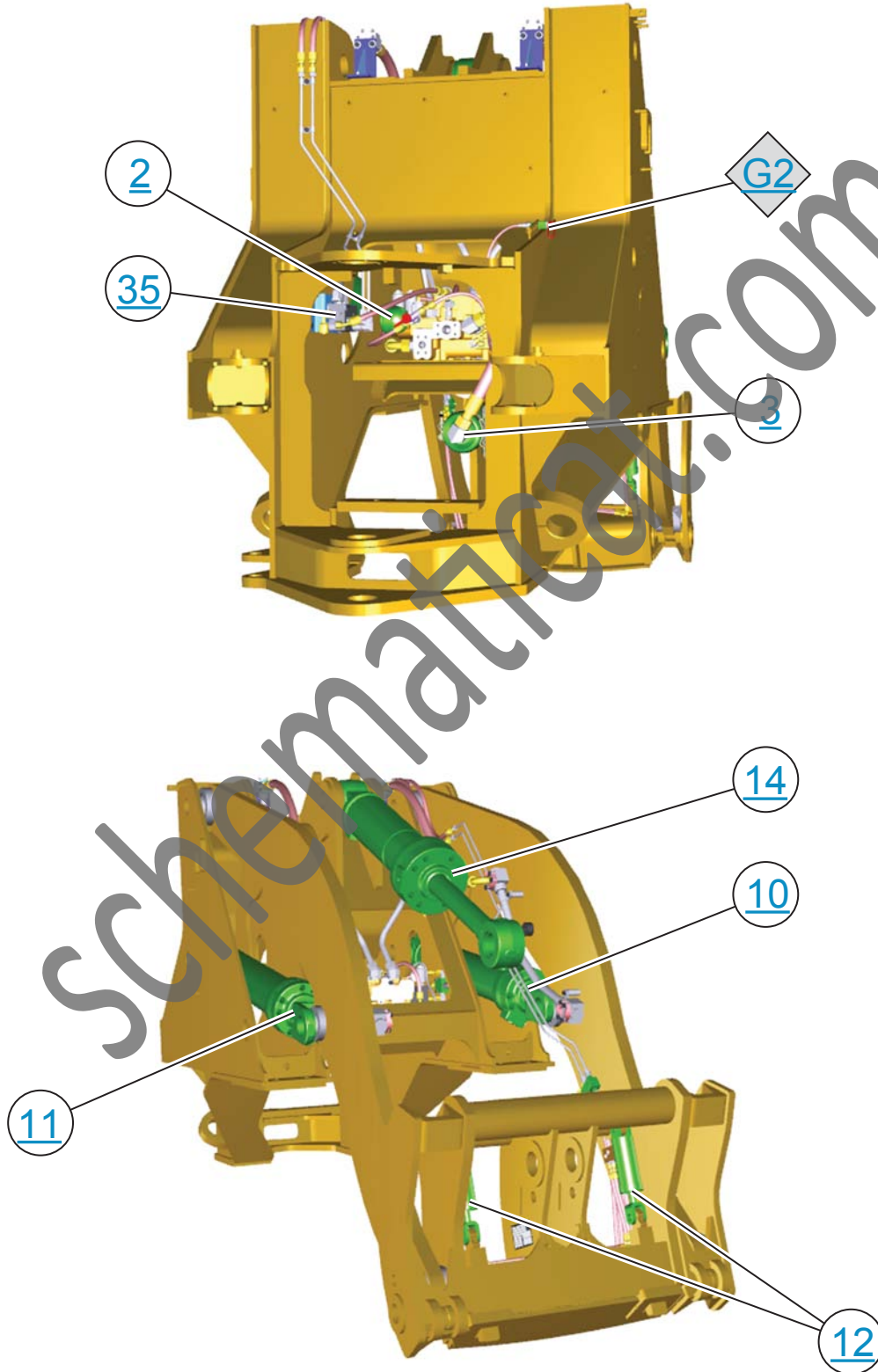

HAND METERING UNIT

