

Component Location			
Description	Part Number	Machine Location	Schematic Location
Accumulator GP - Brake	213-8773	1	D-7
Actuator AS - Park Brake	128-6090	2	F-5
Breather AS	312-2884	3	A-6
Control GP - Foot Brake	351-8418	4	F-6
Core AS - Hydraulic Oil Cooler Standard	348-2518	5	E-8
Cylinder GP - Steering	349-7889	6	F-1
Fiber GP - Case Drain	138-1537	7	A-6
Fiber GP - Kidney Loop	295-6259	8	B-8
Motor GP - Fan	246-6152	9	D-8
Pump GP - Fan	358-2517	10	A-8
Pump GP - H&U Metering	349-4794	11	E-3
Pump GP - Implement	319-6308	12	C-6
Pump GP - Steering	241-9299	13	B-5
Pump GP - Transmission	344-7793	14	B-6
Screen AS	97-9227	15	A-6
Sensor GP - Brake Accumulator Pressure	296-5270	16	C-8
Sensor GP - Park Brake Pressure	296-5270	17	D-7
Sensor GP - Position	269-1882	18	F-7
Switch AS - Limit	105-6117	19	F-7
Tank GP - Hydraulic	318-5643	20	A-6
Valve AS - Check	175-0447	21	B-8
Valve GP - Backpressure Check	349-8844	22	B-4
Valve GP - Brake	375-3887	23	E-6
Valve GP - Cooler Bypass Check	358-2512	24	D-8
Valve GP - Fan Drive and Brake Charge	347-3252	25	C-8
Valve GP - H&U Neutralizer	296-5662	26	F-3
Valve GP - H&U Steering	142-6000	27	F-2
Valve GP - Park Brake	349-4389	28	D-7
Valve GP - Steering Backup Relief	132-5258	29	E-3
Valve GP - Steering Convolver Relief	129-5222	30	F-2
<b>Attachments</b>			
Core AS - Axle Oil Cooler	313-7721	31	D-6
Fiber GP - Axle Oil Cooler	291-6351	32	D-5
Motor and Pump GP - Axle Oil Cooling	336-1566	33	D-5
Pump GP - Steer Steering	320-6384	34	B-4
Screen GP	154-2883	35	D-2
Sensor GP - Steer Steering Pressure	296-5270	36	C-5
Valve GP - Axle Oil Cooler Check	130-5202	37	D-6
Valve GP - CCS Check	111-1778	38	D-3
Valve GP - CCS Neutralizer	321-5283	39	D-2
Valve GP - CCS Pilot	147-1790	40	D-3
Valve GP - CCS Steering	124-8635	41	C-1
Valve GP - Check	321-7987	42	C-5
Valve GP - Cold Start Valve	332-1166	43	B-7
Valve GP - Pressure Reducing	114-1267	44	C-2
Valve GP - Shuttle	83-6875	45	C-3

Tap Location Pressure and Sampling		
Tap Number	Description	Schematic Location
G1	Fan Pump Gauge	B-8
G2	Fan Pump Load Sense Gauge	A-8
G3	Front Brake Pressure	F-8
G4	Brake Accumulator Gauge Port	C-8
G5	Rear Brake Pressure	E-6
G7	Steering Pump Discharge Gauge	C-5
G8	Steering Pump Load Sense Gauge	E-4
G9	CCS Steering Neutral Pilot Pressure	C-3
G10	CCS Steering Left Pilot Pressure	D-2
G11	CCS Steering Right Pilot Pressure	D-1
G12	CCS Steering Resolved Pilot Pressure	C-3
G13	Case Drain Air Bleed	B-8
D14	Park Brake Pressure	F-5
SOS	Oil Sampling Port	F-8

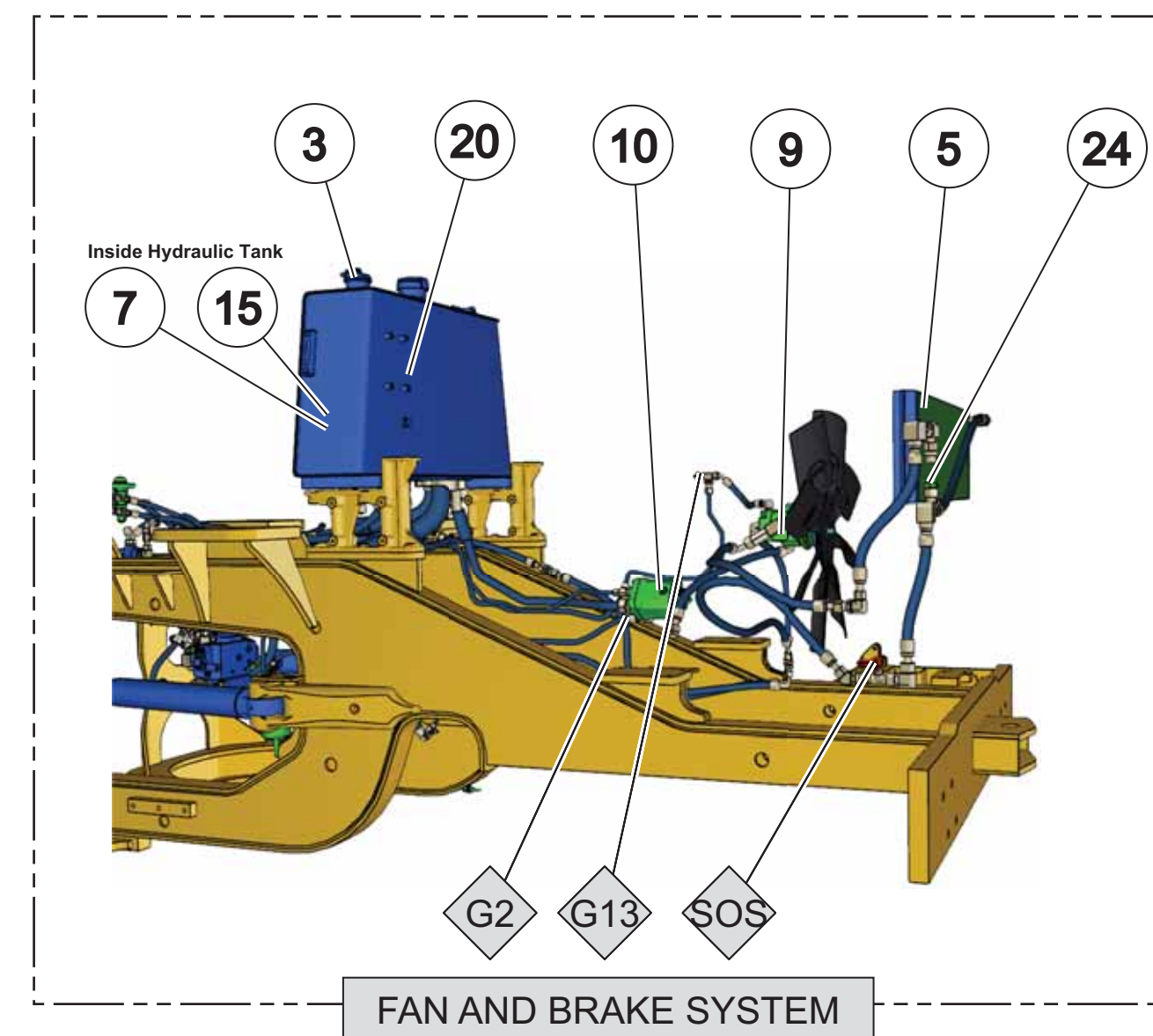
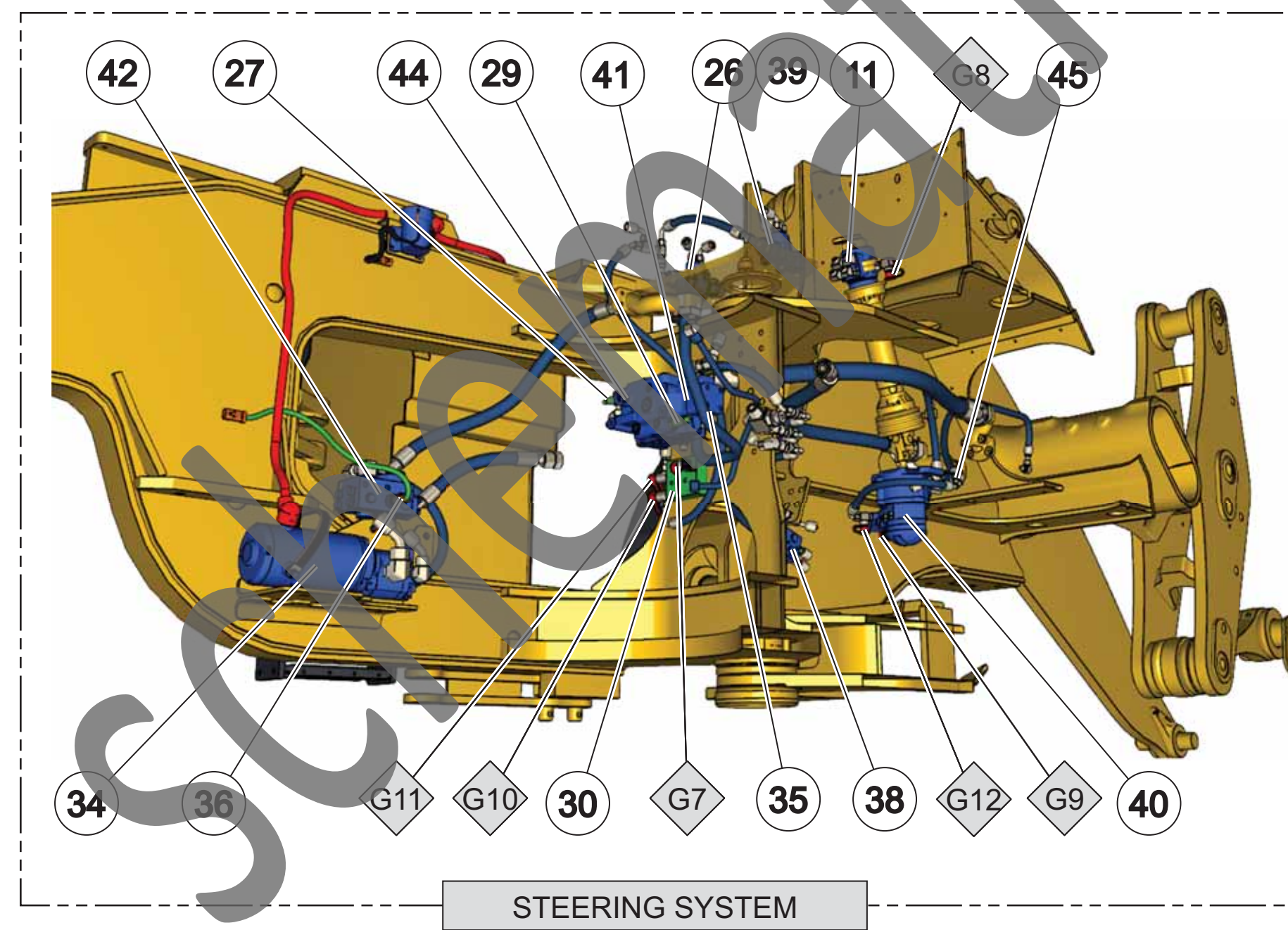
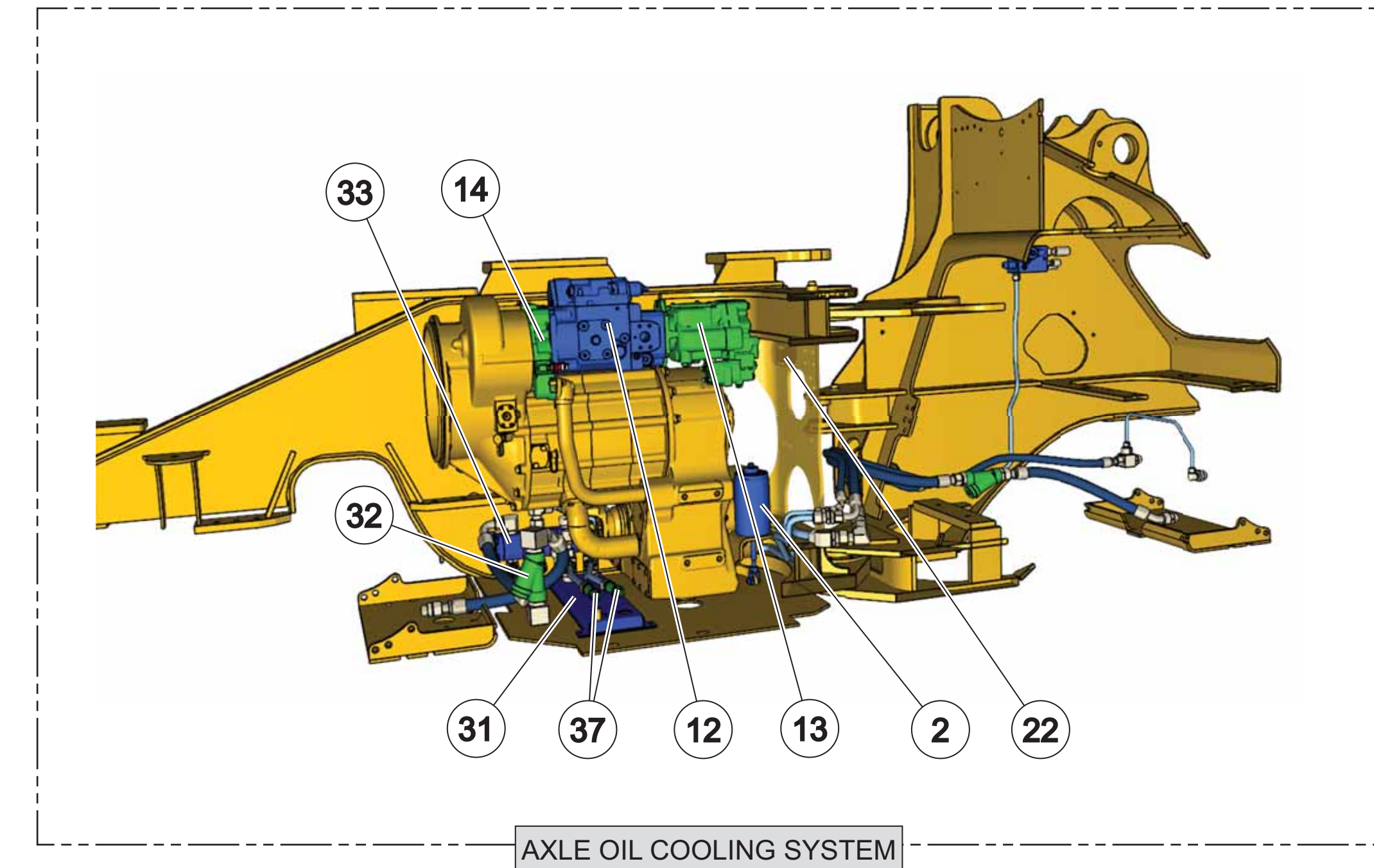

# Schematic

## 950K and 962K Wheel Loader Hydraulic System

950K:  
R4A1-1409  
J5M1-999  
FER1-366

962K:  
T6A1-999  
FLL1-259  
X4T1-482

Volume 1 of 2: Steering and Brake

© 2014 Caterpillar. All Rights Reserved

Printed in U.S.A.

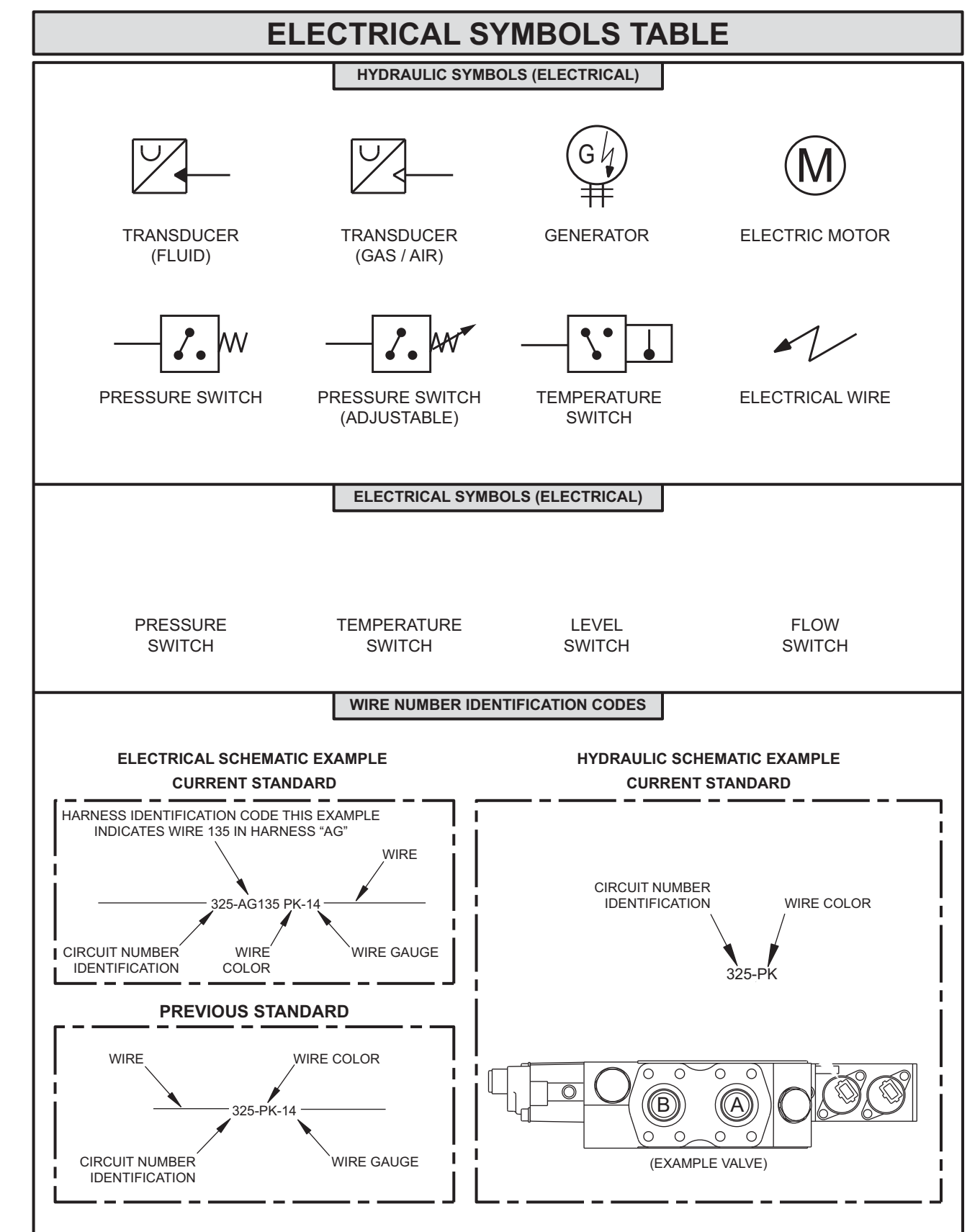
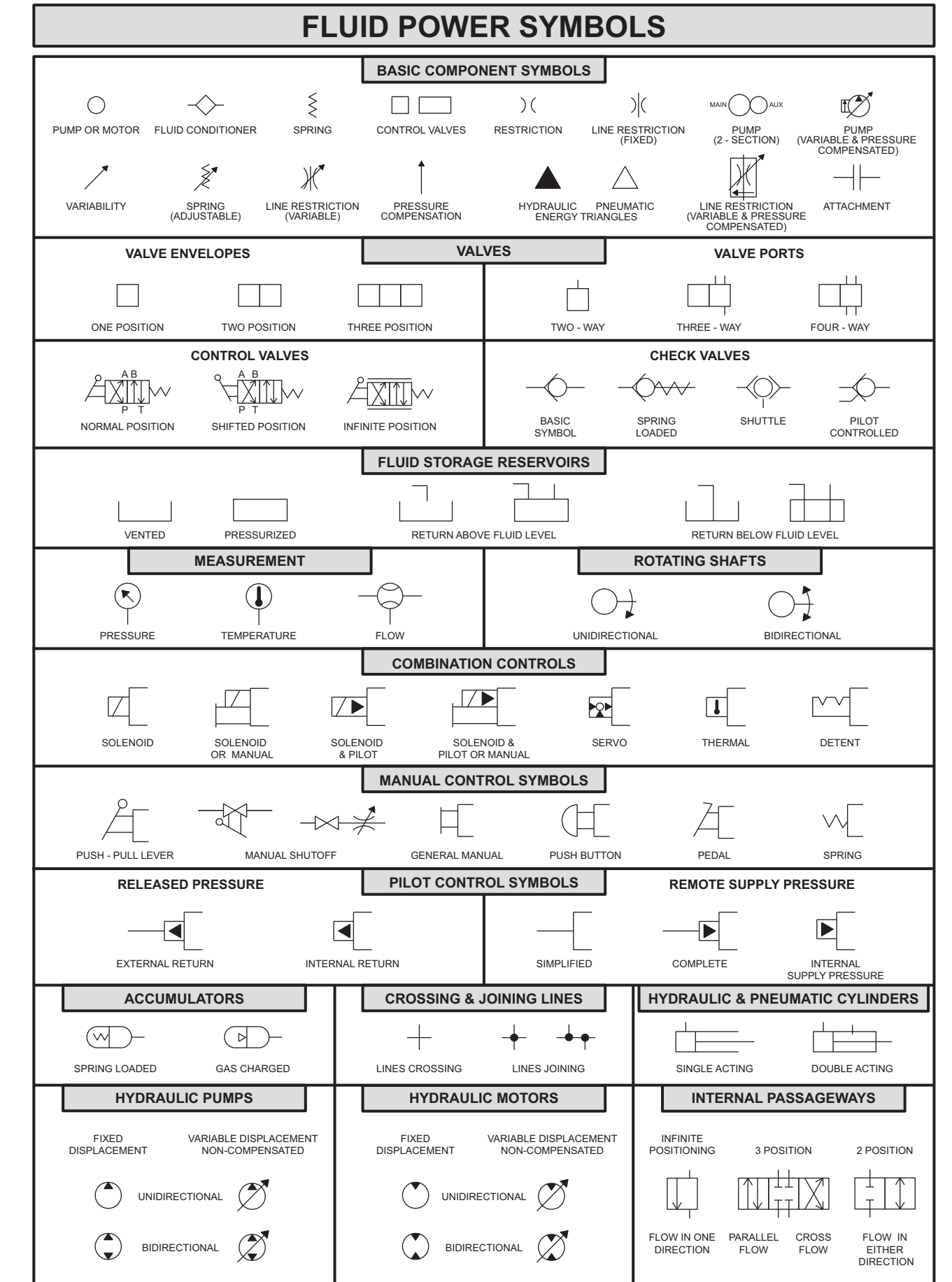

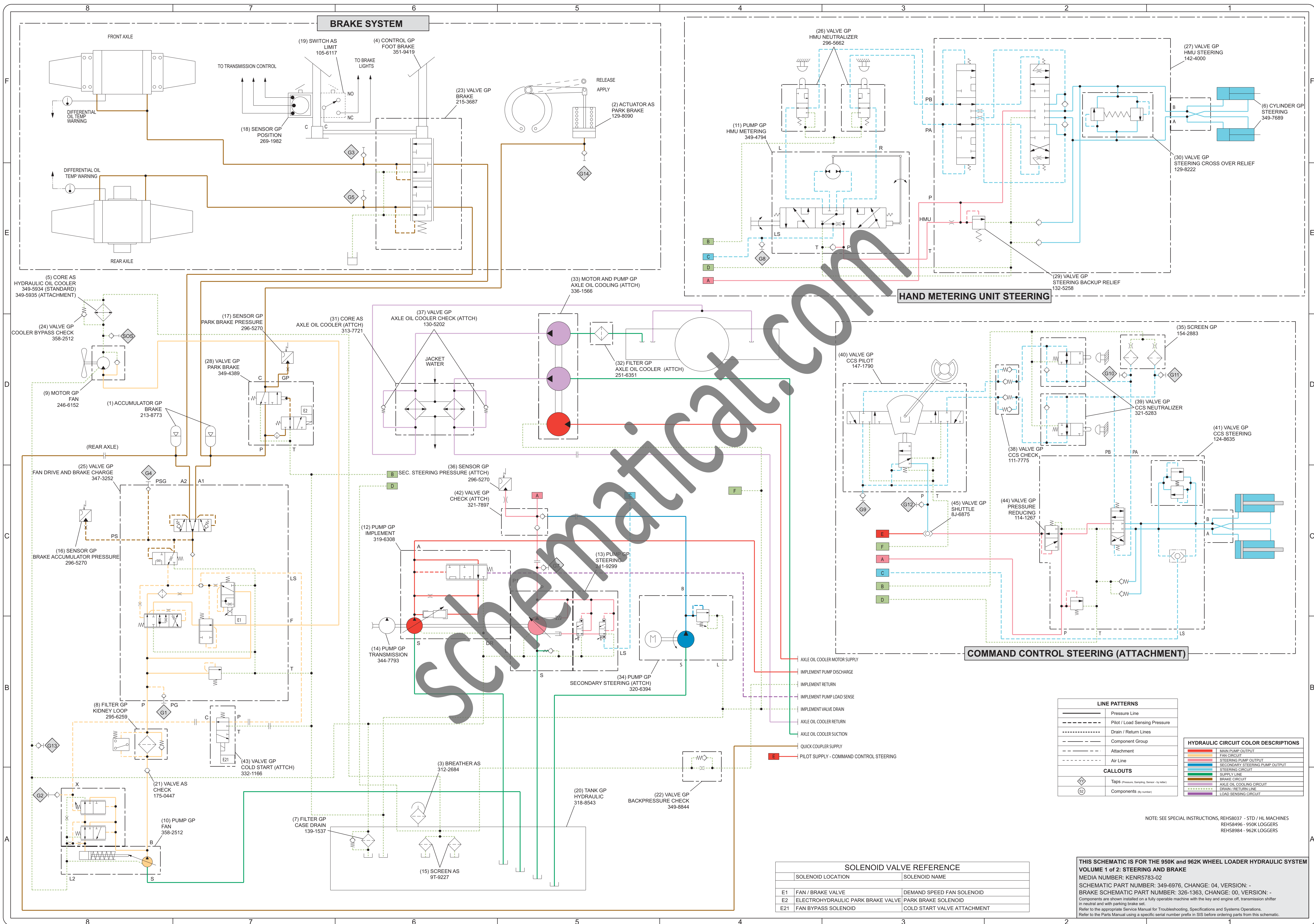

LINE PATTERNS	
—	Pressure Line
- - -	Pilot / Load Sensing Pressure
· · · · ·	Drain / Return Lines
- - - - -	Component Group
- - - - -	Attachment
- - - - -	Air Line
○	Taps (Pressure, Suction, Return, by letter)
⊗	Components (by number)

  

HYDRAULIC CIRCUIT COLOR DESCRIPTIONS	
Red	MAIN PUMP OUTPUT
Orange	FAN CIRCUIT
Yellow	STEERING PUMP OUTPUT
Green	SECONDARY STEERING PUMP OUTPUT
Blue	STEERING CIRCUIT
Purple	SUPPLY LINE
Light Blue	BRAKE CIRCUIT
Light Green	AXLE OIL COOLING CIRCUIT
Light Purple	DRAIN / RETURN LINE
Light Orange	LOAD SENSING CIRCUIT

SOLENOID VALVE REFERENCE	
SOLENOID LOCATION	SOLENOID NAME
E1	FAN / BRAKE VALVE
E2	ELECTROHYDRAULIC PARK BRAKE VALVE
E21	FAN BYPASS SOLENOID
	DEMAND SPEED FAN SOLENOID
	PARK BRAKE SOLENOID
	COLD START VALVE ATTACHMENT

**THIS SCHEMATIC IS FOR THE 950K AND 962K WHEEL LOADER HYDRAULIC SYSTEM VOLUME 1 of 2: STEERING AND BRAKE**  
 MEDIA NUMBER: KENR5783-02  
 SCHEMATIC PART NUMBER: 349-6976, CHANGE: 04, VERSION: -  
 BRAKE SCHEMATIC PART NUMBER: 326-1363, CHANGE: 00, VERSION: -  
 Components are shown installed on a fully operable machine with the key and engine off, transmission shifter in neutral and with parking brake set.  
 Refer to the appropriate Service Manual for Troubleshooting, Specifications and Systems Operations.  
 Refer to the Parts Manual using a specific serial number prefix in SIS before ordering parts from this schematic.

NOTE: SEE SPECIAL INSTRUCTIONS, REHS8037 - STD / HL MACHINES  
 REHS8496 - 950K LOGGERS  
 REHS8984 - 962K LOGGERS

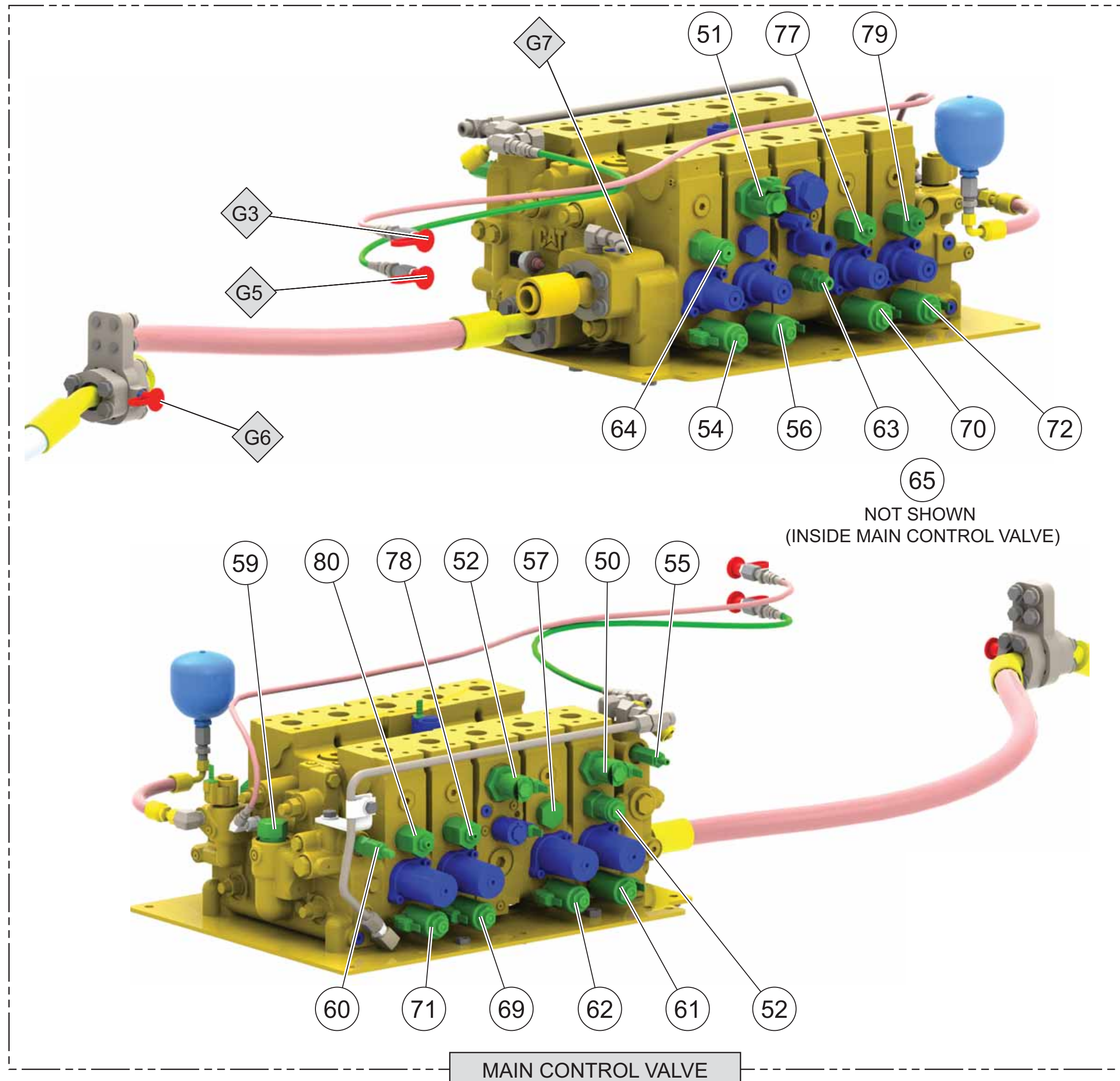

Component Location			
Description	Part Number	Machine Location	Schematic Location
Accumulator GP - Pilot	355-9681	46	E-2
Accumulator GP - Ride Control	360-6512	47	F-4
Cylinder GP - Lift 962 Standard, Logger 950 High Lift, 962 Standard 962 Logger, 962 High Lift	347-6541	48	F-5
Cylinder GP - Tilt 950 Standard 962 Standard 950 High Lift 962 High Lift 962 Logger	347-5542 347-6538 347-5543 347-5544 347-6539 347-5540	49	F-6
Valve GP - Anti Drrt Solenoid	328-4314	50	E-5
Valve GP - Anti Drrt Solenoid Lift Circuit	328-4314	51	E-7
Valve GP - Anti Drrt Solenoid Tilt Circuit	328-4314	52	E-6
Valve GP - Control 2 Function Standard 2 Function With Ride Control 3 Function With Ride Control 4 Function With Ride Control	321-0037 338-8944 318-8450 318-8457	53	F-7
Valve GP - Dump Solenoid	313-7668	54	D-6
Valve GP - Load Sense Relief	313-7668	55	D-7
Valve GP - Lower / Float Solenoid	313-7668	56	D-5
Valve GP - Make Up	234-4969	57	E-6
Valve GP - Manual Lower	112-1817	58	F-8
Valve GP - Margin Relief	331-9022	59	D-3
Valve GP - Pressure Reducing	335-1074	60	E-3
Valve GP - Rack Back Solenoid	313-7668	61	E-6
Valve GP - Raise Solenoid	313-7668	62	E-5
Valve GP - Relief Ride Control	47-7581	63	E-5
Valve GP - Relief Tilt	332-1987	64	E-6
Valve GP - Shuttle Ride Control Pressure	235-6157	65	D-5
Attachments			
Connector Orifice	235-3079	66	A-5
Cylinder GP - Quick Coupler	311-1463	67	B-6
Filter GP - Axle Oil Cooler Magnetic	251-6351	68	B-4
Valve GP - 3rd Function Port A Solenoid	313-7668	69	E-4
Valve GP - 3rd Function Port B Solenoid	313-7668	70	D-4
Valve GP - 4th Function Port A Solenoid	313-7668	71	E-4
Valve GP - 4th Function Port B Solenoid	313-7668	72	D-3
Valve GP - ACC Load Sense Check	123-4750	73	F-1
Valve GP - Axle Oil Cooler	344-7563	74	F-1
Valve GP - Manual Release	112-1817	75	B-6
Valve GP - Quick Coupler	321-8473	76	A-6
Valve GP - Relief 3rd Function 1	272-2334	77	E-3
Valve GP - Relief 3rd Function 2	272-2334	78	E-3
Valve GP - Relief 4th Function 1	272-2334	79	E-4
Valve GP - Relief 4th Function 2	272-2334	80	E-4

Tap Location Pressure and Sampling		
Tap Number	Description	Schematic Location
G3	Pilot Supply Gauge Port	E-2
G5	Implement Pump Discharge Gauge Port	E-7
G6	Implement Pump Load Sense Gauge Port	D-7
G7	Steering Pump Load Sense Gauge Port	E-7

Related Manuals		
Description	Media Number	
Parts Manual:		
Parts Book:	3EBP0720	
Machine System:		
Disassembly and Assembly Machine System:	KENR5783	
Specifications:	KENR5783	
Electrical System:		
Schematic:	KENR5784	

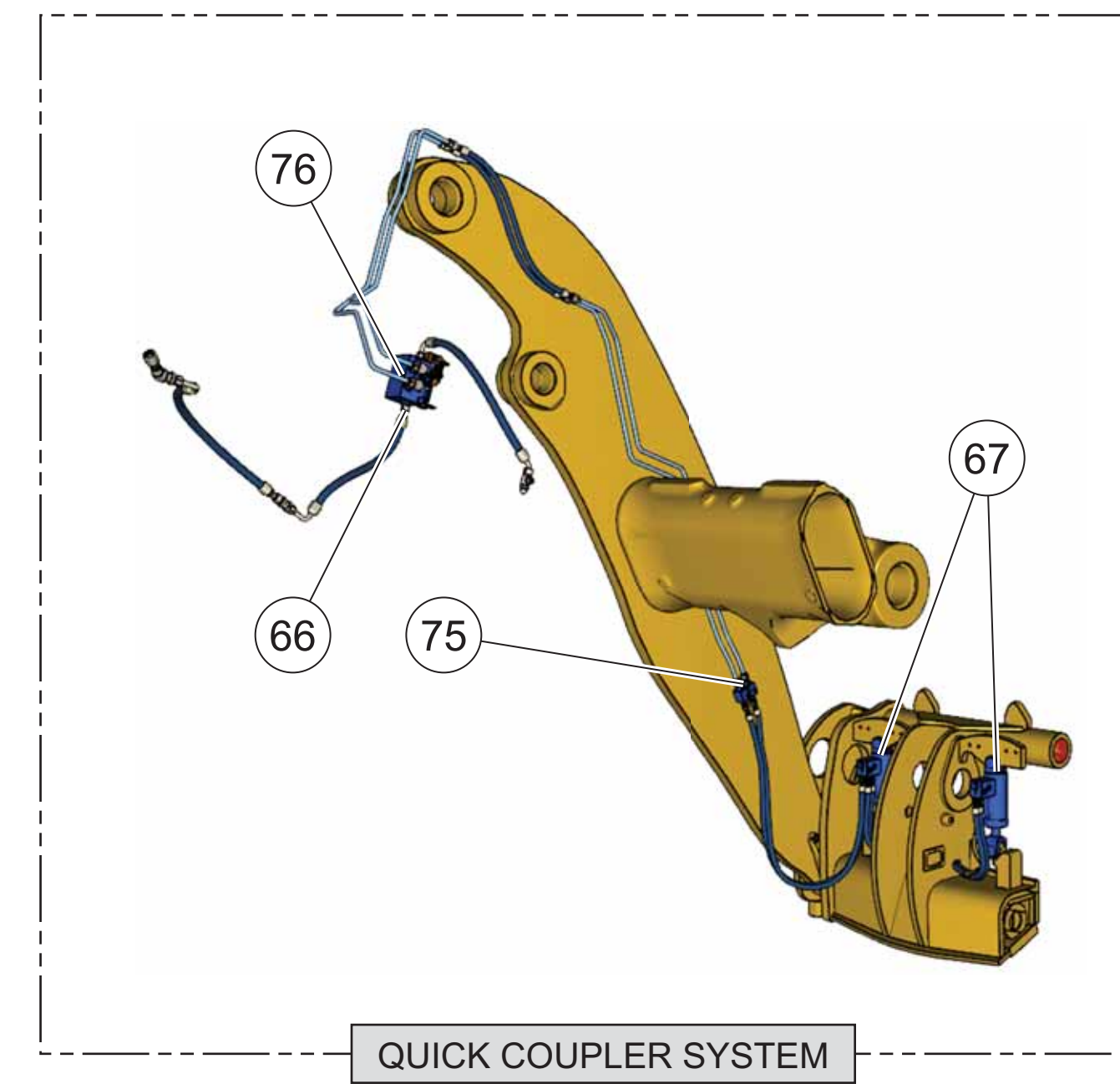
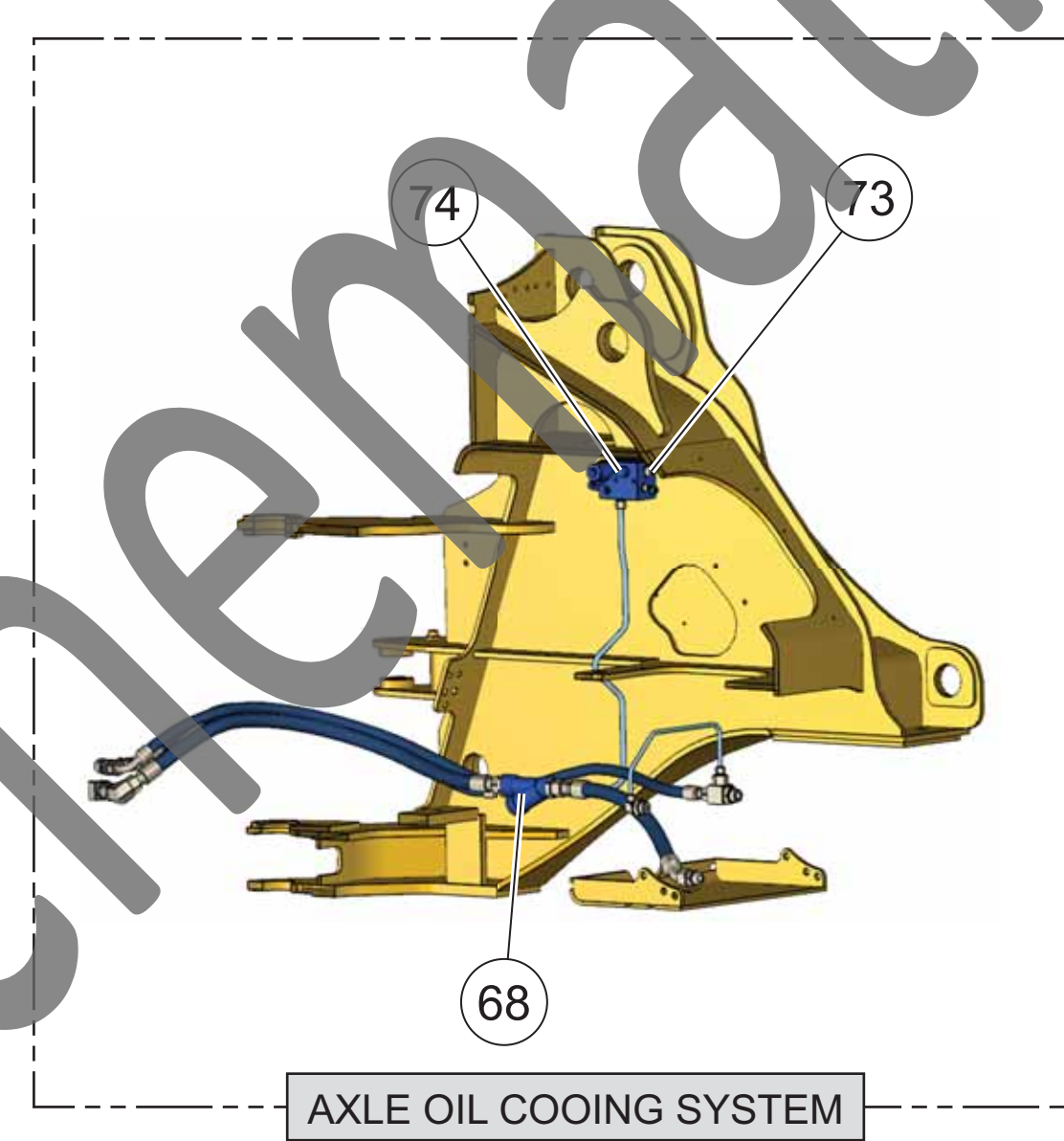
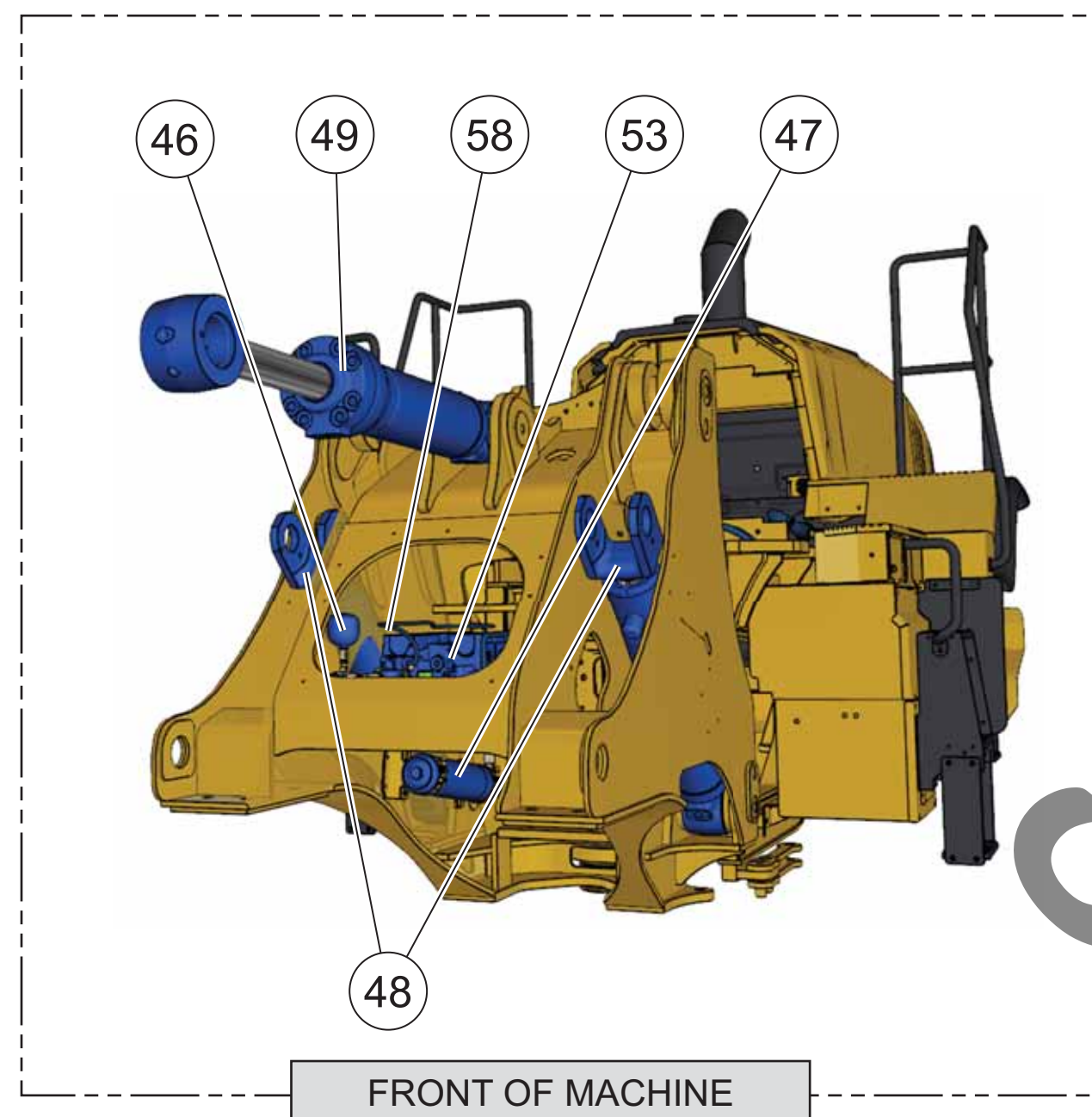

# Schematic

## 950K and 962K Wheel Loader Hydraulic System

950K: R4A1-1409 J5M1-999 FER1-366  
962K: T6A1-999 FLL1-259 X4T1-482

Volume 2 of 2: Main Control Valve

© 2014 Caterpillar, All Rights Reserved

Printed in U.S.A.

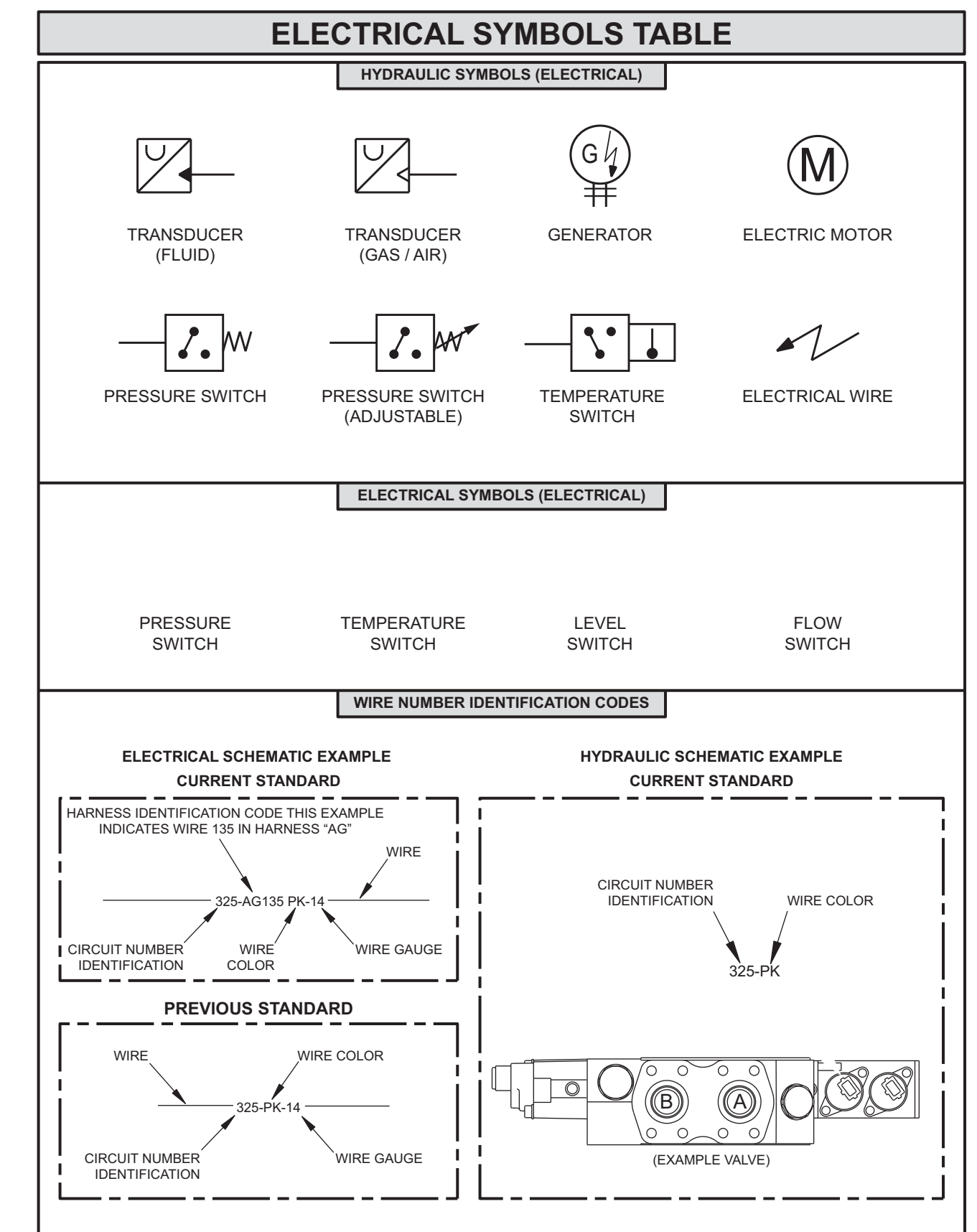
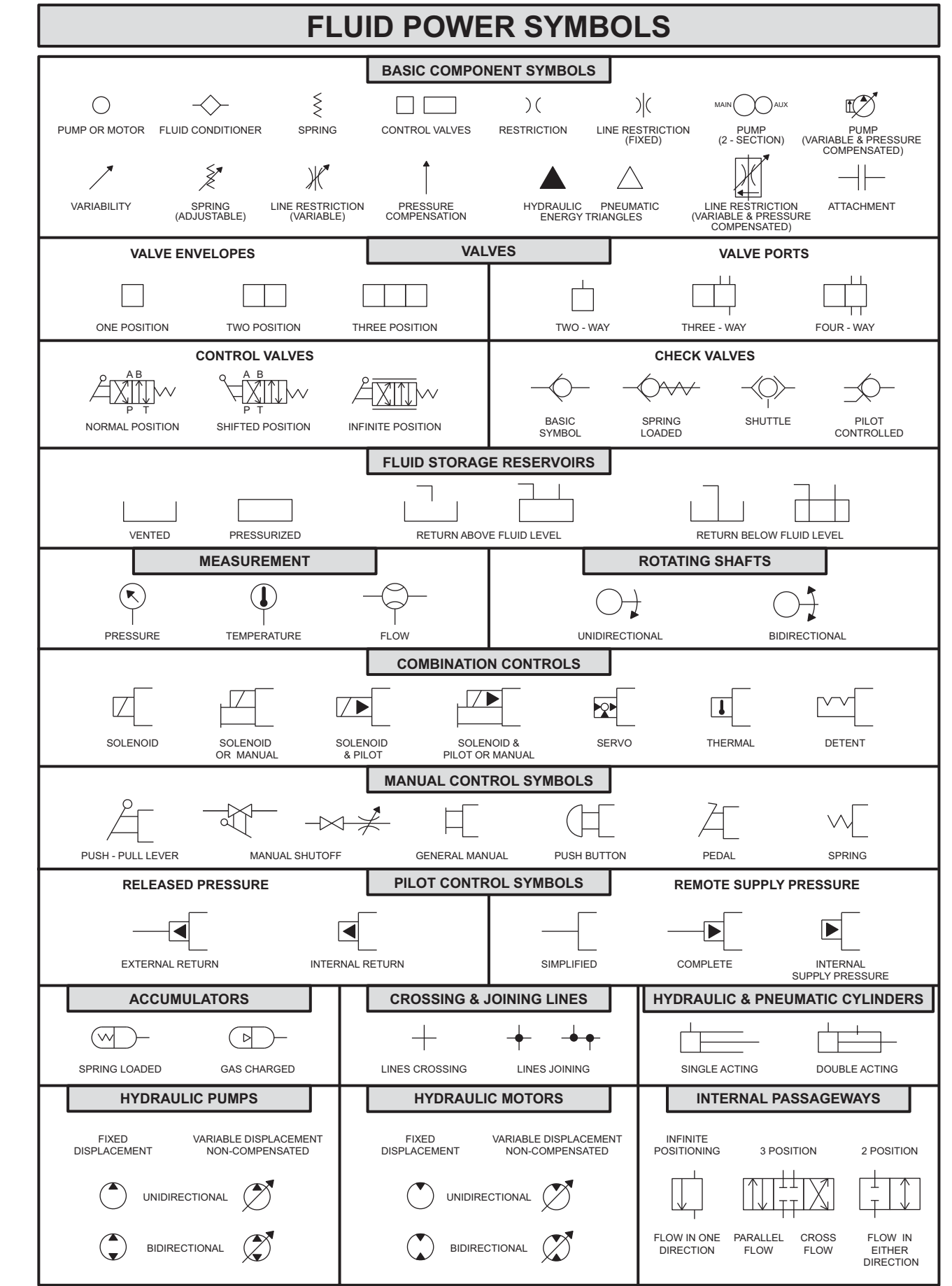

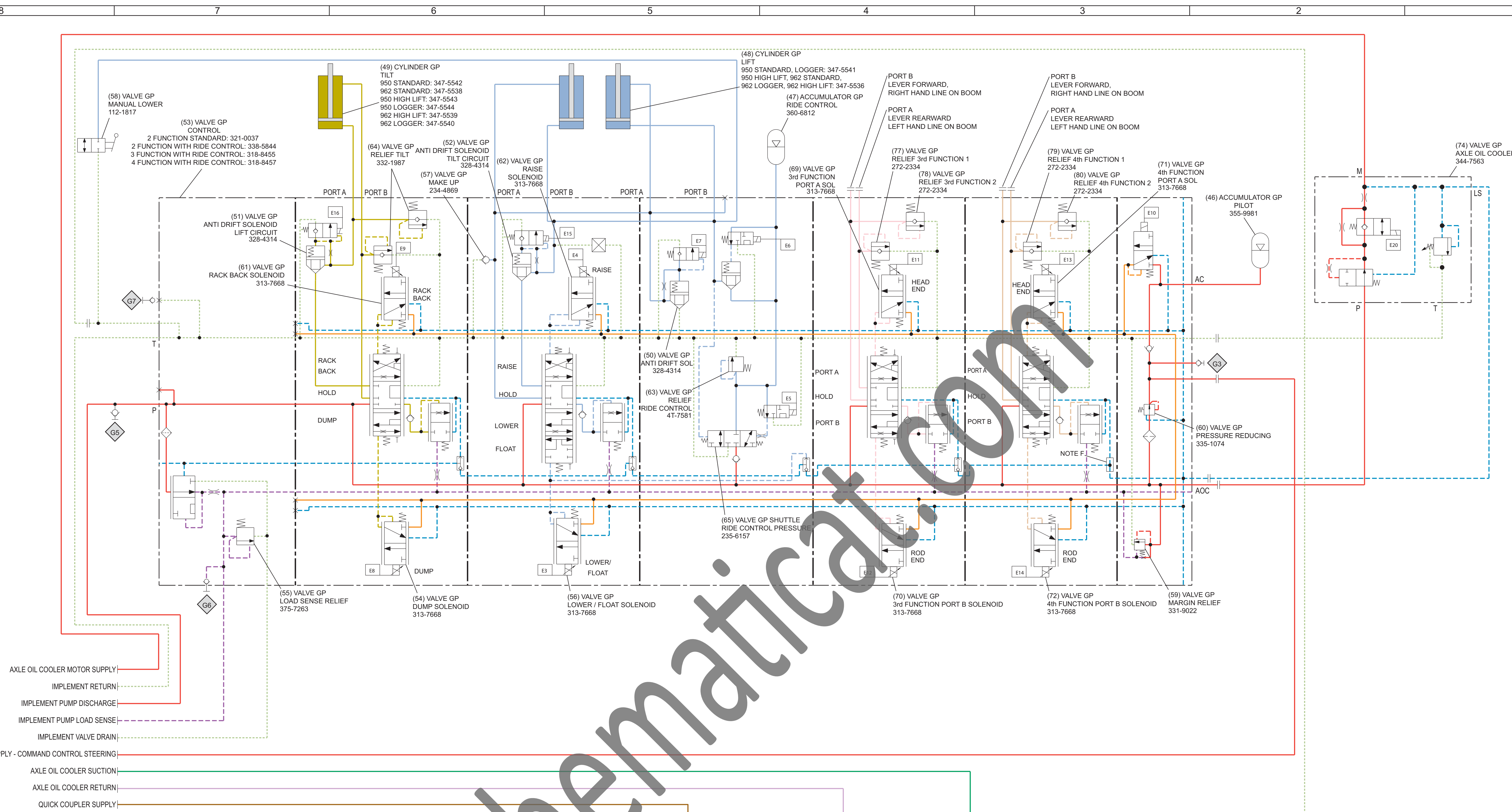

AXLE OIL COOLER MOTOR SUPPLY  
 IMPLEMENT RETURN  
 IMPLEMENT PUMP DISCHARGE  
 IMPLEMENT PUMP LOAD SENSE  
 IMPLEMENT VALVE DRAIN  
 PILOT SUPPLY - COMMAND CONTROL STEERING  
 AXLE OIL COOLER SUCTION  
 AXLE OIL COOLER RETURN  
 QUICK COUPLER SUPPLY

SOLENOID VALVE REFERENCE		
SOLENOID LOCATION	SOLENOID NAME	
E3	IMPLEMENT VALVE - LIFT	LOWER SOLENOID
E4	IMPLEMENT VALVE - LIFT	RAISE SOLENOID
E5	IMPLEMENT VALVE - RIDE CONTROL	RIDE CONTROL BALANCE SOLENOID
E6	IMPLEMENT VALVE - RIDE CONTROL	RIDE CONTROL HEAD END CHECK SOLENOID
E7	IMPLEMENT VALVE - RIDE CONTROL	RIDE CONTROL ROD END CHECK SOLENOID
E8	IMPLEMENT VALVE - TILT	DUMP SOLENOID
E9	IMPLEMENT VALVE - TILT	RACK BACK SOLENOID
E10	IMPLEMENT VALVE	IMPLEMENT PILOT SUPPORT SOLENOID
E11	IMPLEMENT VALVE - 3RD FUNCTION	3RD FUNCTION PORT A SOLENOID
E12	IMPLEMENT VALVE - 3RD FUNCTION	3RD FUNCTION PORT B SOLENOID
E13	IMPLEMENT VALVE - 4TH FUNCTION	4TH FUNCTION PORT A SOLENOID
E14	IMPLEMENT VALVE - 4TH FUNCTION	4TH FUNCTION PORT B SOLENOID
E15	IMPLEMENT VALVE - LIFT	LOWER ANTI-DRIFT SOLENOID
E16	IMPLEMENT VALVE - TILT	DUMP ANTI-DRIFT SOLENOID
E17	QUICK COUPLER VALVE	ENGAGE SOLENOID
E18	QUICK COUPLER VALVE	DISENGAGE SOLENOID
E19	QUICK COUPLER VALVE	ENABLE SOLENOID
E20	AXLE OIL COOLING VALVE ATTACHMENT	AXLE OIL COOLING SOLENOID

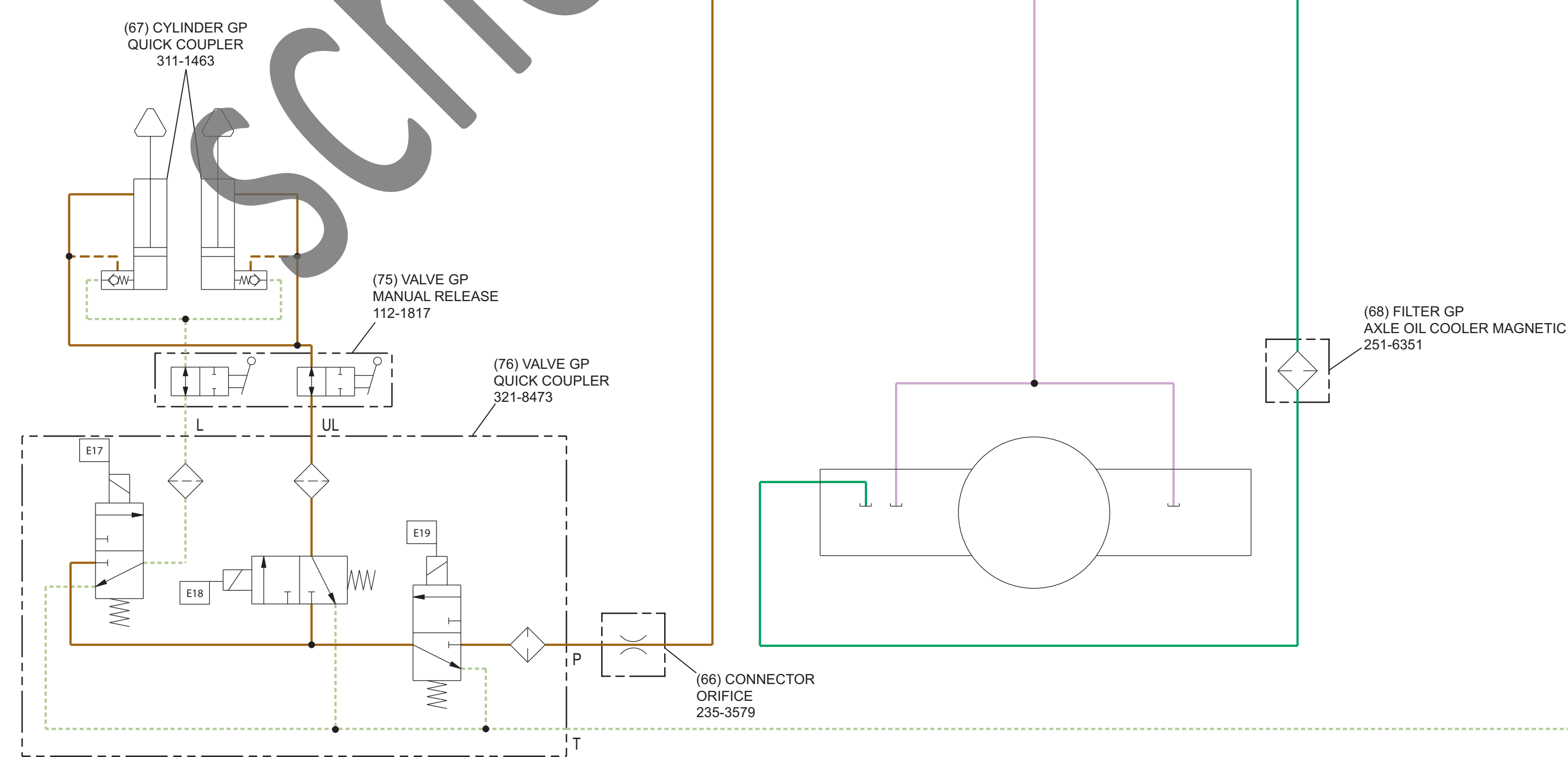

LINE PATTERNS	
—	Pressure Line
- - - -	Pilot / Load Sensing Pressure
· · · · ·	Drain / Return Lines
- - - - -	Component Group
- - - - -	Attachment
- - - - -	Air Line

CALLOUTS	
⬠	TapS (Pressure Sampling Sensor - by letter)
Ⓢ	ComponentS (by number)

HYDRAULIC CIRCUIT COLOR DESCRIPTIONS	
Orange	PILOT PUMP OUTPUT
Red	MAIN PUMP OUTPUT
Green	SUPPLY LINE
Blue	BRAKE CIRCUIT
Yellow	3RD FUNCTION CIRCUIT
Purple	AXLE OIL COOLING CIRCUIT
Light Blue	DRAIN / RETURN LINE
Light Green	TILT CIRCUIT
Light Yellow	LOAD SENSING CIRCUIT
Light Purple	LIFT CIRCUIT
Light Blue	4TH FUNCTION CIRCUIT
Light Green	IMPLEMENT PUMP LOAD SENSING CIRCUIT

NOTE F - ADD RESOLVER IN THE LAST SECTION WHENEVER AOC IS USED

**THIS SCHEMATIC IS FOR THE 950K AND 962K WHEEL LOADER HYDRAULIC SYSTEM**  
**VOLUME 2 of 2: MAIN CONTROL VALVE**  
 MEDIA NUMBER: KENR5783-02  
 SCHEMATIC PART NUMBER: 349-6976, CHANGE: 04, VERSION: -  
 Components are shown installed on a fully operable machine with the key and engine off, transmission shifter in neutral and with parking brake set.  
 Refer to the appropriate Service Manual for Troubleshooting, Specifications and Systems Operations.  
 Refer to the Parts Manual using a specific serial number prefix in SIS before ordering parts from this schematic.